

OS2 75

bilico | pivot

CATALOGO

TECNICO

TECHNICAL

CATALOGUE

METALFORM

secco

1	Informazioni generali / General informations	
	Descrizione del sistema / System description	1.1.1
	Tipologie e limiti dimensionali / Typologies and dimensional limits	1.2.1-2
2	Componenti del sistema / System component	
	Profili / Profiles	2.1.1 – 2.1.4
	Accessori / Accessories	2.2.1 – 2.2.3
	Squadrette / Brackets	2.3.1 – 2.3.2
	Maniglie / Handles	2.4.1
	Guarnizioni / Gaskets	2.5.1
	Attrezzature / Working tools	2.6.1
	Prodotti / Products	2.7.1 – 2.7.2
	Fermavetri / Glazing beads	2.8.1 – 2.8.8
3	Tecnica del sistema / System technique	
	Sezioni / Sections	3.1.1 – 3.1.9
	Attacchi a muro / Attachment to structure	3.2.1 – 3.2.4
4	Lavorazioni e ciclo produttivo / Processing plan	
	Ciclo produttivo finestra a bilico / Pivoting window processing plan	4.1.1
	Distinte di taglio - Lista componenti / Cutting list - Component list	4.2.1 – 4.2.8
	Lavorazioni su barra / Bar workings	4.3.1 – 4.3.15
	Assiemaggio / Assembling	4.4.1 – 4.4.19
	Applicazione accessori / Accessory installation	4.5.1 – 4.5.9
	Vetrazione / Glazing	4.6.1
5	Note generali sul processo / Processing general informations	
	Raccomandazioni per la lavorazione / Working recommendations	5.1.1 – 5.1.5
	Taglio, asolature, forature / Cutting, slots, holes	5.2.1 – 5.2.2
	Senso di apertura / Side opening	5.3.1
	Controllo qualità / Quality control activities	5.4.1 – 5.4.2
	Materiali e finiture / Material and finishing	5.5.1 – 5.5.2
	Indice analitico / Subject index	5.6.1

Sistema integrato di profili, accessori e guarnizioni a taglio termico con profili aventi sezione in vista di 62 mm, dedicato alla realizzazione di serramenti con aperutra a bilico verticale e orizzontale

I **profili in metallo** componenti il sistema sono dello spessore di 15/10 mm e sono ottenuti tramite profilatura a freddo di nastri nei vari materiali previsti dal sistema.

Il **taglio termico** dei profili è realizzato tramite un estruso in poliammide rinforzato con fibra di vetro reso solidale alle parti in metallo esterne da una resina poliuretanicca ad alta densità, iniettata ad alta pressione. Il collegamento che si ottiene è continuo, privo di interruzioni e garantisce la massima resistenza torsionale e flettente.

La **costruzione dei telai** prevede l'unione tra i profili tramite saldatura in continuo delle sezioni in contatto e la successiva ripresa delle superfici in vista, o l'utilizzo di un sistema misto ad assiemaggio meccanico a saldatura interna che non necessita di riprese di finitura.

Il sistema prevede al possibilità di alloggiare **vetri stratificati** (di sicurezza) a una o più camere.

Caratteristiche del sistema:

Sormonto interno ed esterno delle ante;

Sistema a 3 livelli di tenuta per apertura interna, con guarnizione di giunto aperto e guarnizione interna ed esterna di battuta per le migliori prestazioni di tenuta all'aria e all'acqua e di isolamento acustico;

Doppia guarnizione di battuta per l'apertura esterna;

Sistema integrato completo di accessori per lo scarico acqua nello stesso materiale del profilo;

Kit completo per l'apertura a bilico con ferramenta integrata al profilo;

Accessori di movimentazione negli stessi materiali del profilo.

System of thermally broken profiles, accessories and gaskets with visible section of 62 mm suitable for vertical and horizontal pivoting windows.

The metal profiles that make up the system are 15/10 mm thick and are obtained from the cold-forming of the coils in the various materials available.

The profile thermal break is connected by means of a glass-fibre reinforced, extruded polyamide that becomes one with the external metal parts with the use of a high density polyurethane resin, injected at high pressure. The connection is continuous, without interruptions, guaranteeing maximum resilience to torsional and bending stress.

The assembly of the frames requires that the profiles be connected by welding together the sections in contact and then that the visible welds must be ground down neatly and finished, or by combining mechanical assembly and internal welding that does not require the retouching of the finish.

The system permits to use double or triple thermal insulated glazing with **stratified glass** (security glass).

Features of the system:

Surmounted internal and external design of the sections ;

System with 3 barriers of tightness for inward opening, with central gasket and internal and external rebate gasket and for the best water and air tightness and acoustic performances;

Double rebate gasket for outwards opening leaf;

Integrated system complete of accessories for water drain in the material of profile;

Full set of accessories for vertical pivoting windows with integrated ironmongery;

Pivot bearing in the same material of profile.

PRESTAZIONI

Sistema

Trasmittanza termica (EN ISO 10077-2)

- Nodo tipo: $U_f = 2,50 \text{ W/m}^2\text{K}$

Bilico verticale

Resistenza all'aria (DIN EN 12207)

- Fino a Classe 4

Resistenza all'acqua (DIN EN 12208)

- Fino a Classe 6A

Resistenza al vento (DIN EN 12210)

- Fino a Classe C5

Prova di durata a cicli di apertura (DIN EN 1197-12400)

- Fino a Classe 2 - 10.000 cicli

Bilico orizzontale

Resistenza all'aria (DIN EN 12207)

- Fino a Classe 4

Resistenza all'acqua (DIN EN 12208)

- Fino a Classe 7A

Resistenza al vento (DIN EN 12210)

- Fino a Classe C3

PERFORMANCES

System

Thermal transmittance (EN ISO 10077-2)

- Typical section: $U_f = 2,50 \text{ W/m}^2\text{K}$

Vertical pivot

Air permeability (DIN EN 12207)

- Up to Class 4

Watertightness (DIN EN 12208)

- Up to Class 6A

Resistance to wind load (DIN EN 12210)

- Up to Class C5

Resistance to repeated opening and closing (DIN EN 1197-12400)

- Up to Class 2 - 10 000 opening and closing

Horizontal pivot

Air permeability (DIN EN 12207)

- Up to Class 4

Watertightness (DIN EN 12208)

- Up to Class 7A

Resistance to wind load (DIN EN 12210)

- Up to Class C3

Limiti dimensionali - Maximum dimension

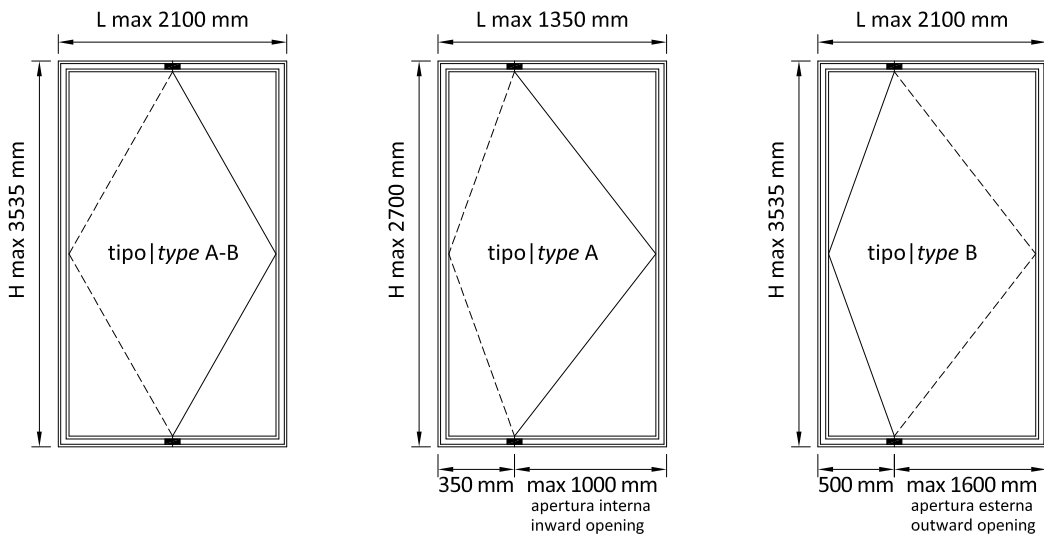

peso massimo anta maximum leaf weight	
tipo type A	100 kg
tipo type B	350 kg

Esempi tipologie realizzabili - Types of windows

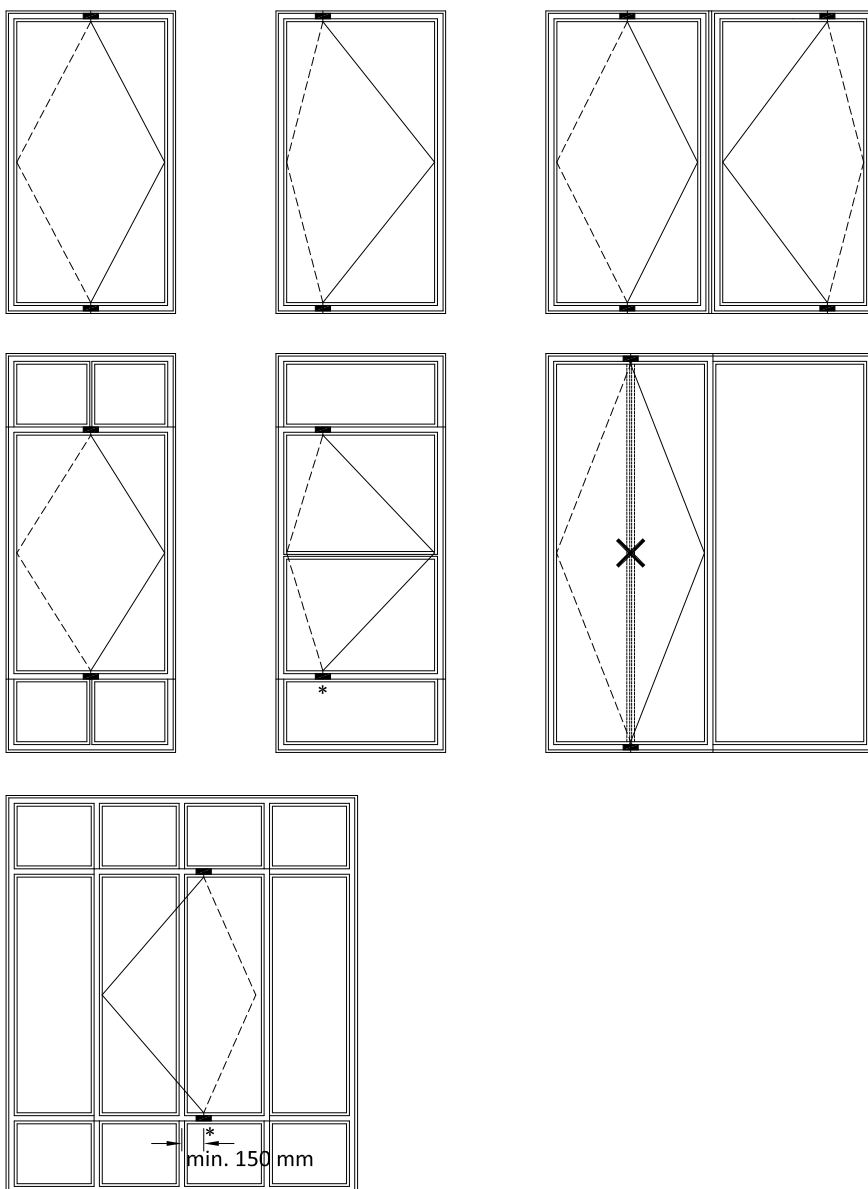

* non realizzabile tipo B | not possible type B

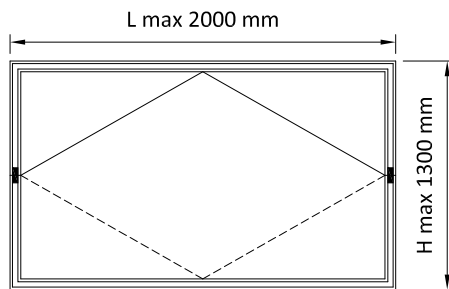
Limiti dimensionali - *Maximum dimension*

peso massimo anta 100 kg
maximum leaf weight 100 kg

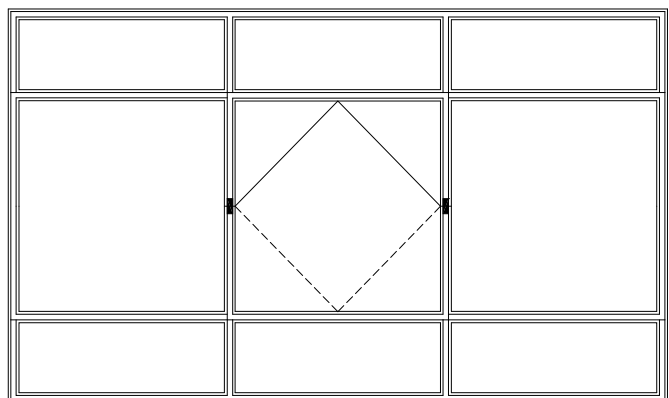
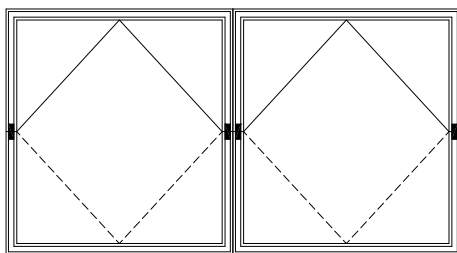
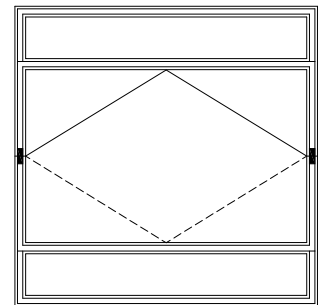
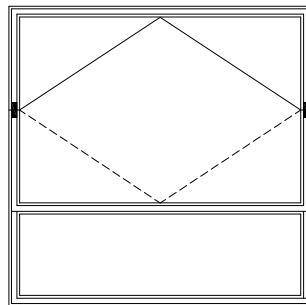
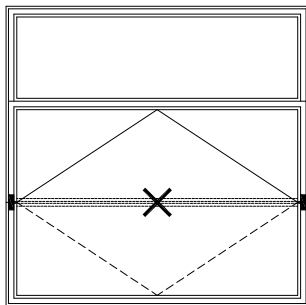
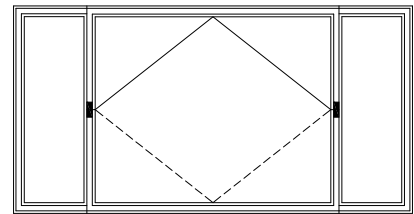
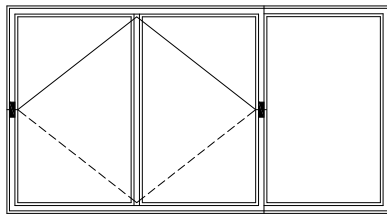
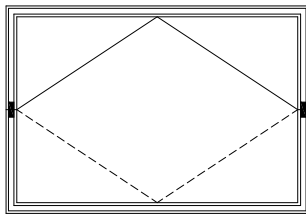
Esempi tipologie realizzabili - *Types of windows*

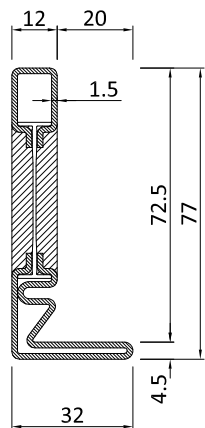

PR2901

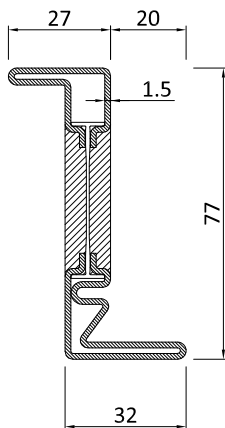

PR2903

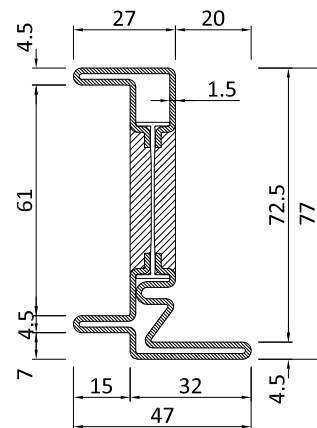

PR2915

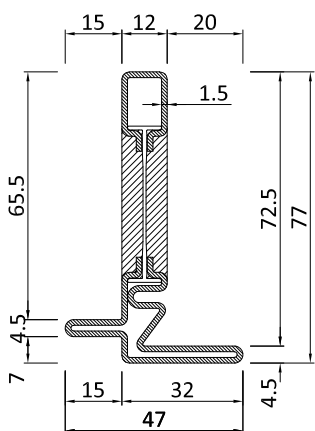

PR2942

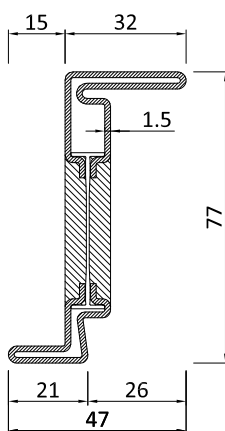

PR2943

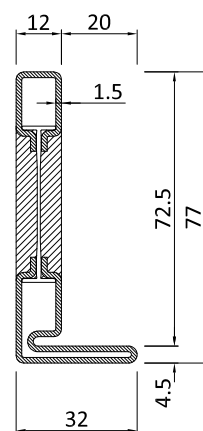

PR2961

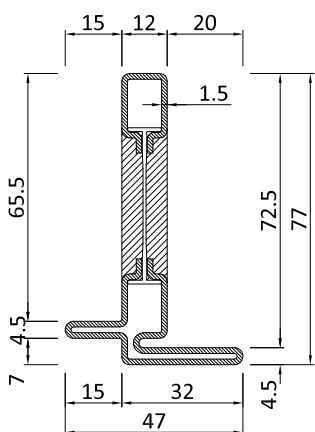

PR2962

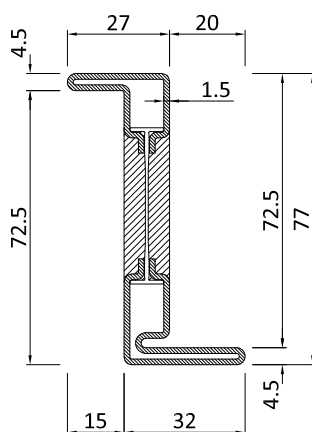

PR2963

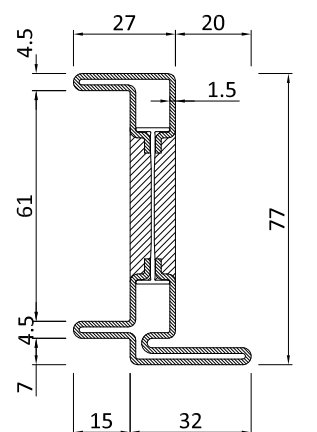

PR2965

Profilo / Profile n°	P Kg/m		A m ² /m	Jx cm ⁴	Jy cm ⁴	L m
	ZN / I - CT	OT				
PR2901	2,53	2,70	0,23	17,03	1,78	6,0
PR2903	2,87	3,07	0,25	22,40	2,80	6,0
PR2915	3,15	3,38	0,29	23,60	3,70	6,0
PR2942	2,81	3,01	0,26	17,75	2,87	6,0
PR2943	2,79	2,96	0,25	21,93	2,3	6,0

Profilo / Profile n°	P Kg/m		A m ² /m	Jx cm ⁴	Jy cm ⁴	L m
	ZN / I - CT	OT				
PR2961	2,46	2,62	0,22	17,16	1,74	6,0
PR2962	2,73	2,92	0,25	17,89	2,97	6,0
PR2963	2,80	2,9	0,25	22,53	2,79	6,0
PR2965	3,07	3,29	0,28	23,73	3,82	6,0

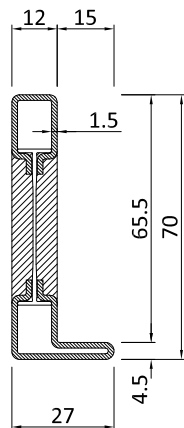

PR2971

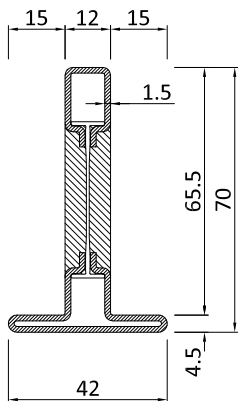

PR2972

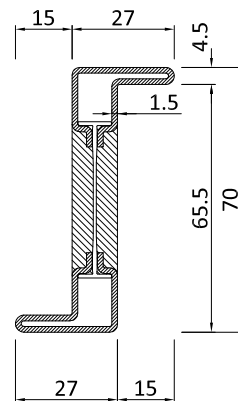

PR2973

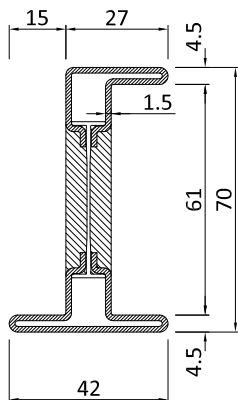

PR2974

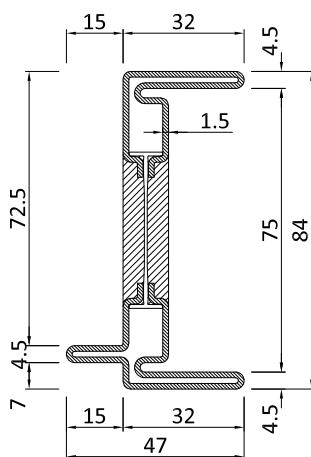

PR2975

Profilo / Profile n°	P Kg/m		A m ² /m	Jx cm ⁴	Jy cm ⁴	L m	Profilo / Profile n°	P Kg/m		A m ² /m	Jx cm ⁴	Jy cm ⁴	L m
	ZN / I - CT	OT						ZN / I - CT	OT				
PR2971	2,01	2,14	0,19	12,45	1,02	6,0							
PR2972	2,34	2,50	0,21	14,17	2,13	6,0							
PR2973	2,35	2,51	0,21	16,29	3,32	6,0							
PR2974	2,68	2,87	0,22	18,81	2,87	6,0							
PR2975	3,52	3,77	0,32	32,75	4,36	6,0							

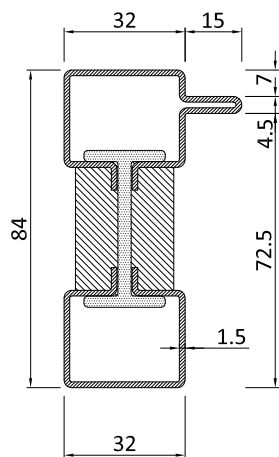

PR2991

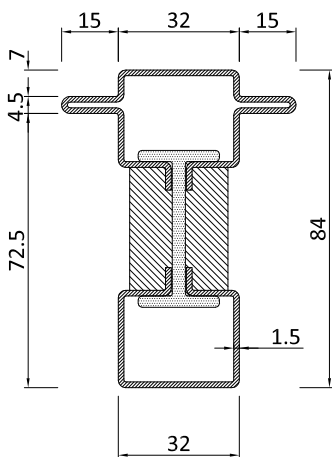

PR2992

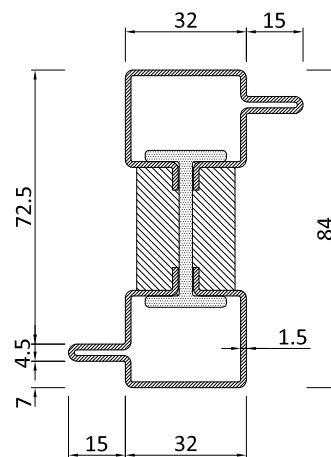

PR2993

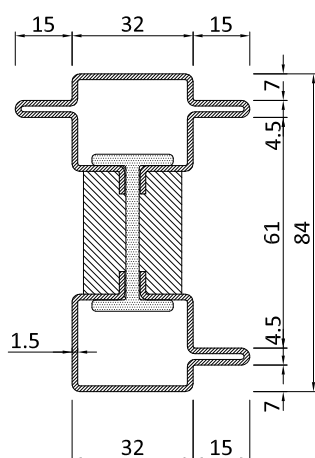

PR2995

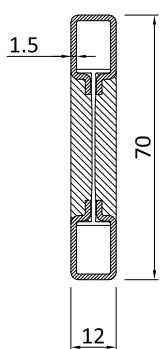

PR2930

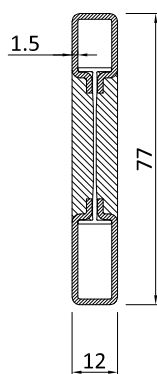

PR2931

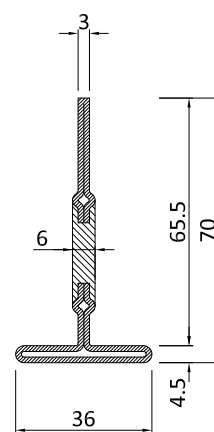

PR2964 Non fornito in Inox
Not in Inox

Profilo / Profile n°	P Kg/m		A m ² /m	Jx cm ⁴	Jy cm ⁴	L m
	ZN / I - CT	OT				
PR2991	3,81	4,06	0,24	25,62	6,58	3,0
PR2992	4,42	4,70	0,26	27,30	9,45	3,0
PR2993	4,49	4,78	0,26	28,62	9,12	3,0
PR2995	4,80	5,11	0,29	30,19	11,62	3,0
PR2930	1,67	1,77	0,16	9,70	031	6,0

Profilo / Profile n°	P Kg/m		A m ² /m	Jx cm ⁴	Jy cm ⁴	L m
	ZN / I - CT	OT				
PR2931	1,84	1,95	0,17	12,37	0,36	6,0
PR2964	2,22	2,40	0,21	14,87	1,20	6,0

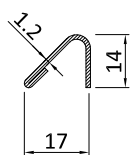

PR2620

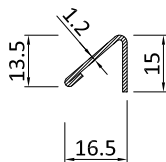

PR2670

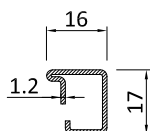

PR2606

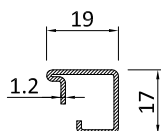

PR2607

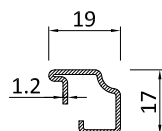

PR2627

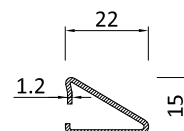

PR2629

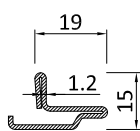

PR2638

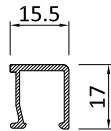

PA2606

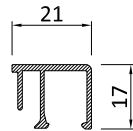

PA2607

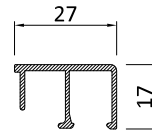

PA2608

MATERIALE | MATERIAL

PR ____ ZN acciaio zincato | *galvanized steel*

PR ____ CZ acciaio corten grezzo | *untreated corteen steel*

PR ____ SB acciaio inox scotch brite | *stainless steel scotch brite*

PR ____ BR ottone grezzo | *untreated brass*

PA ____ alluminio | *aluminium*

Profilo / Profile n°	P Kg/m		A m ² /m	Jx cm ⁴	Jy cm ⁴	L m	Profilo / Profile n°	P Kg/m		A m ² /m	Jx cm ⁴	Jy cm ⁴	L m
	ZN / I - CT	OT						ZN / I - CT	OT				
PR2620	0,24	0,27				4,0	PA2606	0,17	Alluminio				6,0
PR2670	0,40	0,43				4,0	PA2607	0,23	Alluminio				6,0
PR2606	0,48	0,52				6,0	PA2608	0,26	Aluminio				6,0
PR2607	0,51	0,55				6,0							
PR2627	0,47	0,51				6,0							
PR2629	0,49	0,53				6,0							
PR2638	0,60	0,65				6,0							

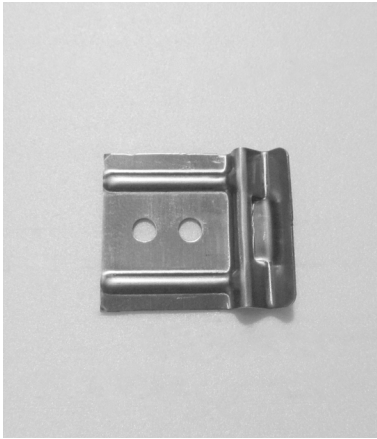

**AC 2608**

Clips per fissaggio fermavetri
PR2606 - PR2607 - PR2627
PR2629 - PR2638

*Clips for securing
PR2606 - PR2607 - PR2627
PR2629 - PR2638
glazing beads*

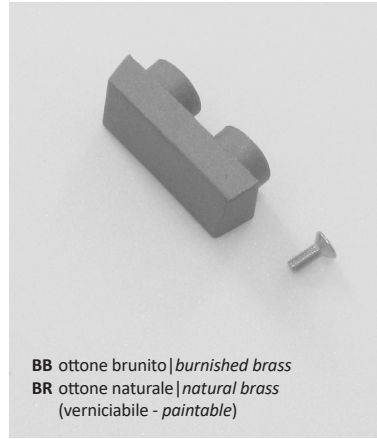
**ACB 219.xx**

Scarico acqua per aperture
interne in ottone

Brass drip for inward openings

BB ottone brunito | *burnished brass*
BR ottone naturale | *natural brass*
(verniciabile - *paintable*)

**AC 2609**

Clips per fissaggio fermavetri
su profilo PR2954 - PR2964

*Clips for securing glazing beads
on PR2954 - PR2964 profile*

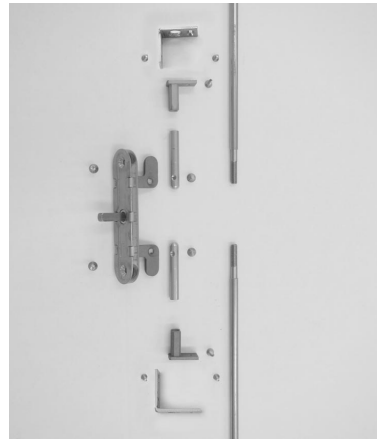
**AC 2625D**

Kit cremonese dx per apertura
interna bilico verticale

*RH cremone bolt set for vertical
pivot inward opening*

AC 2625S

Kit cremonese sx per apertura
interna bilico verticale

*LH cremone bolt set for vertical
pivot inward opening*

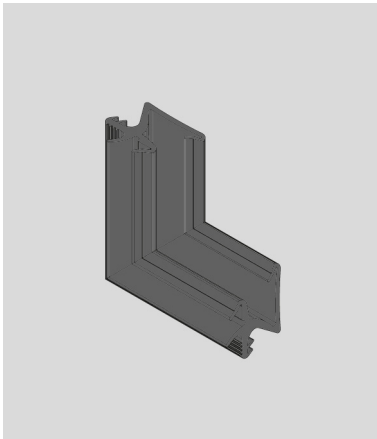
**AC 2617N**

Guarnizione d'angolo
vulcanizzata per GE 2603

*Vulcanised corner gasket
for GE 2603*

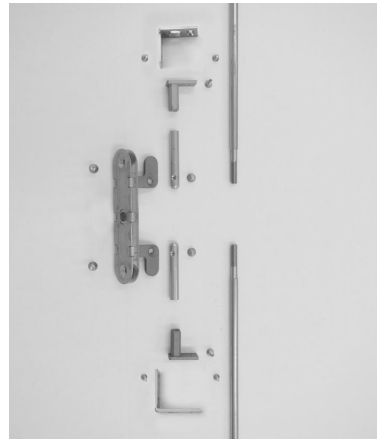
**AC 2625E D**

Kit cremonese dx per apertura
interna bilico verticale

Gratz con maniglia removibile
*RH cremone bolt set for vertical
pivot inward opening*

Gratz mechanism with removable handle

AC 2625E S

Kit cremonese sx per apertura
interna bilico verticale

Gratz con maniglia removibile
*LH cremone bolt set for vertical
pivot inward opening*

Gratz mechanism with removable handle

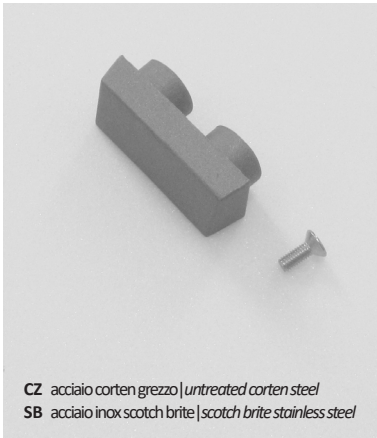
**AC 2618.xx**

Scarico acqua per aperture
interne in metallo

Metal drip for inward openings

AC 2618.NE

Scarico acqua per aperture
interne in plastica nera
Non verniciabile

*Black plastic drip for inward
openings
Non paintable*

CZ acciaio corten grezzo | *untreated corten steel*
SB acciaio inox scotch brite | *scotch brite stainless steel*

**AC 2626R**

Punto di chiusura aggiuntivo
per finestra

*Additional locking point
for windows*

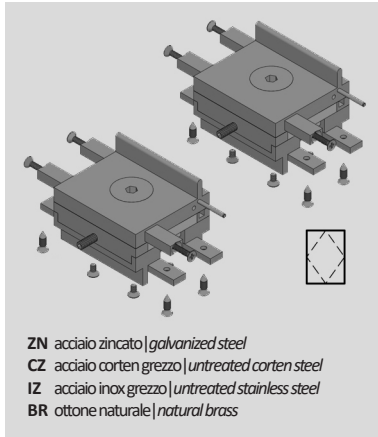
**AC 2533V.**

Coppia cerniere per bilico verticale senza sopra luce superiore o sottoluca inferiore
Telaio PR2915 | PR2965

*Couple hinges for vertical pivot without top light or bottom light
Frame PR2915 | PR2965*

ZN acciaio zincato | galvanized steel
CZ acciaio corten grezzo | untreated corten steel
IZ acciaio inox grezzo | untreated stainless steel
BR ottone naturale | natural brass

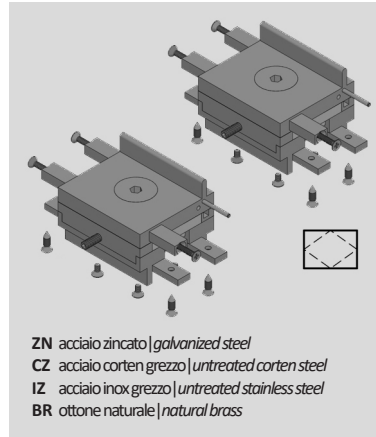
**AC 2533H.**

Coppia cerniere per bilico orizzontale senza laterali fissi
Telaio PR2915 | PR2965

*Couple hinges for horizontal pivot without side light
Frame PR2915 | PR2965*

ZN acciaio zincato | galvanized steel
CZ acciaio corten grezzo | untreated corten steel
IZ acciaio inox grezzo | untreated stainless steel
BR ottone naturale | natural brass

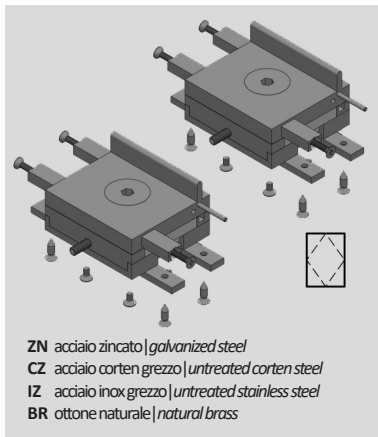
**AC 2533SV.**

Coppia cerniere per bilico verticale senza sopra luce superiore o sottoluca inferiore
Telaio PR2901 | PR2961

*Couple hinges for vertical pivot without top light or bottom light
Frame PR2901 | PR2961*

ZN acciaio zincato | galvanized steel
CZ acciaio corten grezzo | untreated corten steel
IZ acciaio inox grezzo | untreated stainless steel
BR ottone naturale | natural brass

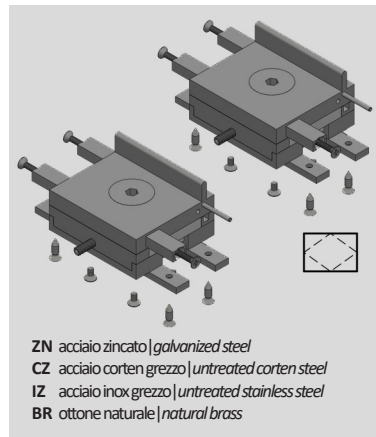
**AC 2533SH.**

Coppia cerniere per bilico orizzontale senza laterali fissi
Telaio PR2901 | PR2961

*Couple hinges for horizontal pivot without side light
Frame PR2901 | PR2961*

ZN acciaio zincato | galvanized steel
CZ acciaio corten grezzo | untreated corten steel
IZ acciaio inox grezzo | untreated stainless steel
BR ottone naturale | natural brass

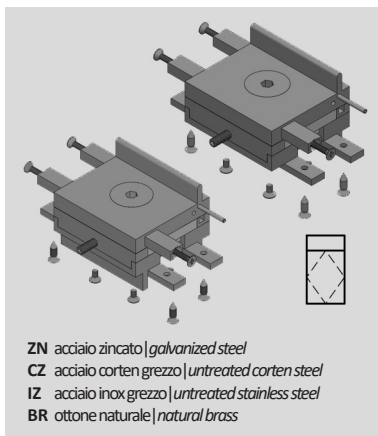
**AC 2537V.**

Coppia cerniere per bilico verticale con sopra luce superiore o sottoluca inferiore

Couple hinges for vertical pivot with top light or bottom light

ZN acciaio zincato | galvanized steel
CZ acciaio corten grezzo | untreated corten steel
IZ acciaio inox grezzo | untreated stainless steel
BR ottone naturale | natural brass

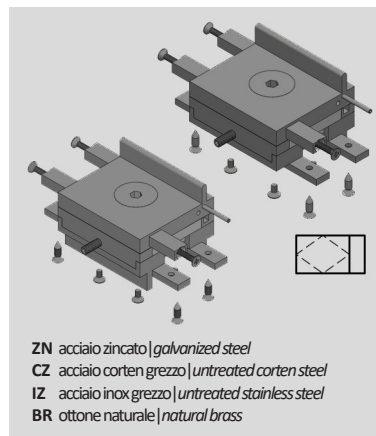
**AC 2537H.**

Coppia cerniere per bilico orizzontale con un laterale fisso

Couple hinges for horizontal pivot with one side light

ZN acciaio zincato | galvanized steel
CZ acciaio corten grezzo | untreated corten steel
IZ acciaio inox grezzo | untreated stainless steel
BR ottone naturale | natural brass

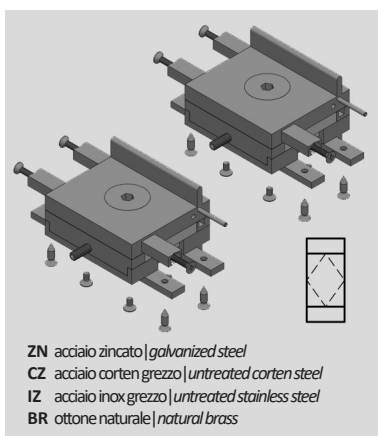
**AC 2538V.**

Coppia cerniere per bilico verticale con sopra luce superiore e sottoluca inferiore

Couple hinges for vertical pivot with top light and bottom light

ZN acciaio zincato | galvanized steel
CZ acciaio corten grezzo | untreated corten steel
IZ acciaio inox grezzo | untreated stainless steel
BR ottone naturale | natural brass

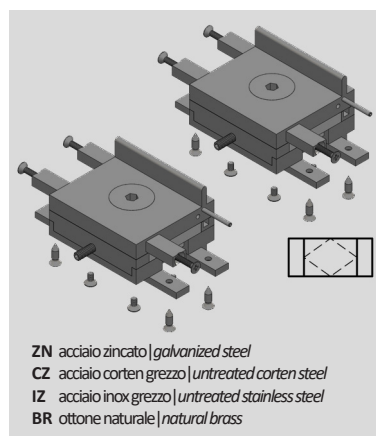
**AC 2538H.**

Coppia cerniere per bilico orizzontale con due laterali fissi

Couple hinges for horizontal pivot with two side light

ZN acciaio zincato | galvanized steel
CZ acciaio corten grezzo | untreated corten steel
IZ acciaio inox grezzo | untreated stainless steel
BR ottone naturale | natural brass

**AC 2658**

Fondino per profili
PR2975 | PR2991 | PR2992
PR2993 | PR2995
(apertura interna)

Fittings for profiles
PR2975 | PR2991 | PR2992
PR2993 | PR2995
(inward opening)

ZN acciaio zincato | *galvanized steel*
CZ acciaio corten | *corten steel*
IZ acciaio inox | *stainless steel*
BR ottone naturale | *natural brass*

**AC 2686**

Braccetto limitatore di apertura
senza blocco

Window restrictor

**AC 2659**

Fondino per profili
PR2975 | PR2991 | PR2992
PR2993 | PR2995
(apertura esterna)

Fittings for profiles
PR2975 | PR2991 | PR2992
PR2993 | PR2995
(outward opening)

ZN acciaio zincato | *galvanized steel*
CZ acciaio corten | *corten steel*
IZ acciaio inox | *stainless steel*
BR ottone naturale | *natural brass*

**CV 1023.**

Vite per boccia fermavetri
in alluminio, TPS 4.2x13

Screw for aluminium glazing
bead bushing, TPS 4.2x13

CV1023 acciaio zincato | *galvanized steel*
CV1023I acciaio inox | *stainless steel*

**AC 2683D**

Kit cremonese dx per apertura
esterna bilico verticale

*RH cremone bolt set for vertical
pivot outward opening*

AC 2683S

Kit cremonese sx per apertura
esterna bilico verticale

*LH cremone bolt set for vertical
pivot outward opening*

**CV 1243.**

Vite trilobata per boccia ferma-
vetri in alluminio, TPS M4x8

*Thread cutting machine screw
for aluminium glazing
bead bushing, TPS M4x8*

CV1243 acciaio zincato | *galvanized steel*
CV1243I acciaio inox | *stainless steel*

**AC 2683E D**

Kit cremonese dx per apertura
esterna bilico verticale
Gratz con maniglia removibile
*RH cremone bolt set for vertical
pivot outward opening
Gratz mechanism with removable handle*

AC 2683E S

Kit cremonese sx per apertura
esterna bilico verticale
Gratz con maniglia removibile
*LH cremone bolt set for vertical
pivot outward opening
Gratz mechanism with removable handle*

**CV 5012.**

Boccia per fermavetri in
alluminio

*Bushing for aluminium
glazing bead*

CV5012 acciaio zincato | *galvanized steel*
CV5012I acciaio inox | *stainless steel*

**AC 2801L**

Kit squadrette allineamento

Alignment bracket set

Profili | Profiles
 PR2901 | PR2901 - PR2922
 PR2901 - PR2903
 PR2901 - PR2905
 PR2903 - PR2922
 PR2901 - PR2942
 PR2903 - PR2942
 PR2905 - PR2942
 PR2942 | PR2915 - P2942
 PR2961 | PR2961 - PR2963
 PR2962 - PR2963 telaio | frame

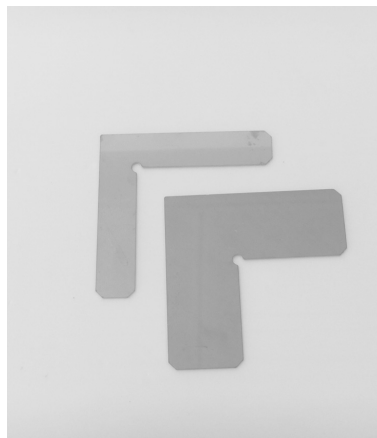
**AC 2855I**

Kit squadrette allineamento

Alignment bracket set

Profili | Profiles
 PR2955
 PR2974

**AC 2803I**

Kit squadrette allineamento

Alignment bracket set

Profili | Profiles
 PR2903
 PR2915
 PR2963
 PR2965 - PR2963

**AC 2862I**

Kit squadrette allineamento

Alignment bracket set

Profili | Profiles
 PR2962

**AC 2843I**

Kit squadrette allineamento

Alignment bracket set

Profili | Profiles
 PR2943

**AC 2865I**

Kit squadrette allineamento

Alignment bracket set

Profili | Profiles
 PR2965

**AC 2853I**

Kit squadrette allineamento

Alignment bracket set

Profili | Profiles
 PR2953
 PR2973

**AC 2871I**

Kit squadrette allineamento

Alignment bracket set

Profili | Profiles
 PR2971

**AC 2872I**

Kit squadrette allineamento

*Alignment bracket set*Profili | Profiles
PR2972**AC 2895I**

Kit squadrette allineamento

*Alignment bracket set*Profili | Profiles
PR2995**AC 2875I**

Kit squadrette allineamento

*Alignment bracket set*Profili | Profiles
PR2975**AC 2891I**

Kit squadrette allineamento

*Alignment bracket set*Profili | Profiles
PR2991**AC 2892I**

Kit squadrette allineamento

*Alignment bracket set*Profili | Profiles
PR2992
PR2993

**ACV 673**

Copertina per gratz con maniglia
removibile su kit
AC2624E|AC2625E
AC2683E|AC2684E

*Cover for gratz mechanism
on kit
AC2624E|AC2625E
AC2683E|AC2684E*

BR ottone grezzo verniciabile | paintable untreated brass
BB ottone brunito | burnished brass
CZ acciaio corten grezzo | untreated corten steel
SB acciaio inox scotch brite | scotch-brite stainless steel

**ACV 774**

Martellina cremonese
"VITRUVIO" small
per finestra
L | tonda | sfera

*Cremone handle
small "VITRUVIO"
for window
L | sphere | round*

BR ottone grezzo verniciabile | paintable untreated brass
BB ottone brunito | burnished brass
CL ottone cromo lucido | polished and chromed brass
OL ottone lucido | polished brass

**ACV 771**

Martellina cremonese
"VITRUVIO" small
per finestra
T | tonda | tronca

*Cremone handle
small "VITRUVIO"
for window
T | cut | round*

BR ottone grezzo verniciabile | paintable untreated brass
BB ottone brunito | burnished brass
CL ottone cromo lucido | polished and chromed brass
OL ottone lucido | polished brass
SB acciaio inox scotch brite | scotch-brite stainless steel

**ACV 776**

Martellina cremonese
"VITRUVIO"
per finestra
KIDS

*Cremone handle
small "VITRUVIO"
for window
KIDS*

BR ottone grezzo verniciabile | paintable untreated brass
BB ottone brunito | burnished brass
CL ottone cromo lucido | polished and chromed brass
OL ottone lucido | polished brass

**ACV 772**

Martellina cremonese
"VITRUVIO" small
per finestra
L | quadra | tronca

*Cremone handle
small "VITRUVIO"
for window
L | cut | square*

IZ inox grezzo verniciabile | paintable stainless steel
CZ acciaio corten grezzo | untreated corten steel
SB acciaio inox scotch brite | scotch-brite stainless steel

**ACV 777**

Martellina cremonese
"VITRUVIO"
per finestra
OVALE

*Cremone handle
small "VITRUVIO"
for window
OVAL*

BR ottone grezzo verniciabile | paintable untreated brass
BB ottone brunito | burnished brass
CL ottone cromo lucido | polished and chromed brass
OL ottone lucido | polished brass

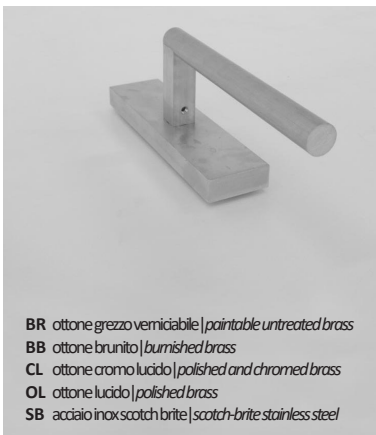
**ACV 773**

Martellina cremonese
"VITRUVIO" small
per finestra
L | tonda | tronca

*Cremone handle
small "VITRUVIO"
for window
L | cut | round*

BR ottone grezzo verniciabile | paintable untreated brass
BB ottone brunito | burnished brass
CL ottone cromo lucido | polished and chromed brass
OL ottone lucido | polished brass
SB acciaio inox scotch brite | scotch-brite stainless steel

**ACV 779**

Martellina cremonese
"VITRUVIO" small
per finestra
T | tonda | sfera

*Cremone handle
small "VITRUVIO"
for window
T | sphere | round*

BR ottone grezzo verniciabile | paintable untreated brass
BB ottone brunito | burnished brass
CL ottone cromo lucido | polished and chromed brass
OL ottone lucido | polished brass

**GE 1011**

Guarnizione interna vetro
spessore 4 mm

*Internal weather strip for
glazing bead
4 mm thick*

**GP 0095**

Guarnizione interna vetro
spessore 3mm

*Internal weather strip for
glazing bead
3 mm thick*

**GE 2603**

Guarnizione per giunto aperto
Apertura interna

*Weather strip for open joint
Inward opening*

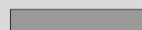
**GU 2036**

Piattina adesiva morbida
per fondo giunto esterno vetro
12x4 mm

*Soft adhesive shim for
external window joint
12x4 mm*

**GE 2606**

Guarnizione adesiva esterno
vetro
vedi pg. 5.1.1

*Adhesive weather strip outer
window
see pg. 5.1.2*

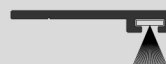
**GU 2865**

Spazzolino superiore per
apertura esterna

*Upper brush window seal for
outward opening*

**GE 2645TT**

Guarnizione di battuta
interna | esterna su profili
PR2943 | PR2963 | PR2962

*Internal/external weather
strip with
PR2943 | PR2962 | PR2963
profiles*

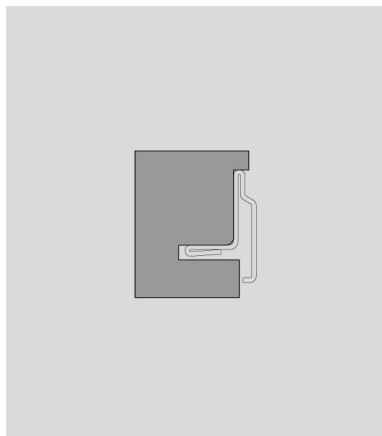
**AT 2038**

Ganasce di taglio per
PR2638

*Cutting jaws for
PR2638*

**AT 2828**

Maschera per esecuzione fori
fissaggio fermavetri

*Drill jig for glazing beads
securing*

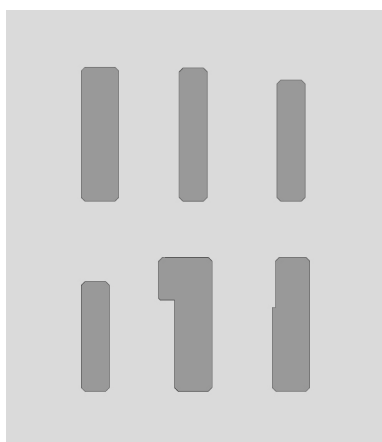
**AT 2900**

Kit ganasce di taglio

Kit of cutting jaws for profiles

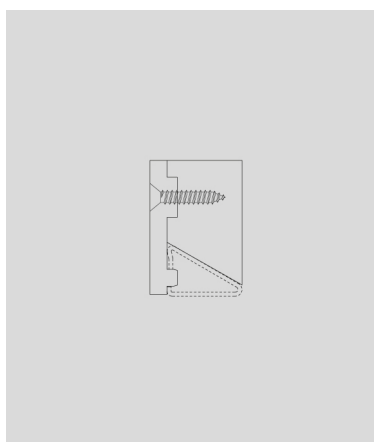
**AT 2829**

Ganasce di taglio per
fermavetro PR2629

*Kit of cutting jaws
for glazing bead PR2629*

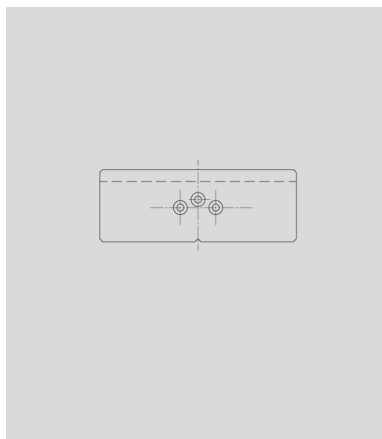
**AT 2818**

Maschera per esecuzione fori
per applicazione scarico acqua
AC2618 - AC2618NE

*Drill jig for AC2618 - AC2618NE
water drip installation*

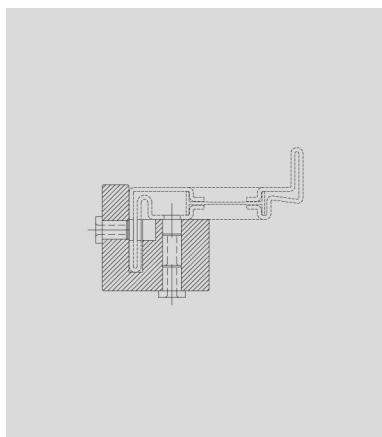
**AT 2825**

Maschera per applicazione
cremonese AC2625 e AC2683

*Jig for AC2625 and AC2683
cremonese bolt installation*

**SA 0005.01**

Liquido neritore per brunitura
1 Kg

Burnishing liquid
1 Kg

SA 0005.10

Liquido neritore per brunitura
10 Kg

Burnishing liquid
10 Kg

**SA 2031**

Liquido deumidificante vetri

Glass dehumidifying liquid

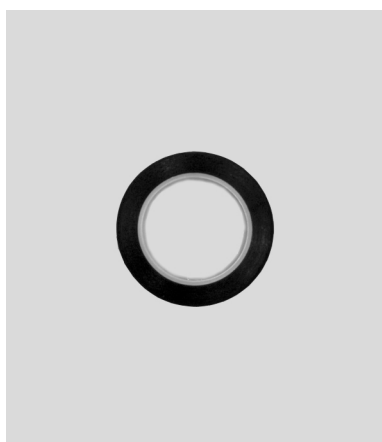
**SA 1033**

Nastro adesivo protettivo per
verniciatura
33 mm

Adhesive tape for painting
33 mm

**SA 2032**

Primer di adesione per profili
verniciati

*Adhesion primer for painted
profiles*

**SA 2001**

Spray detergente antimpronta
per superfici in acciaio inox

*Anti-fingerprint detergent spray
for stainless steel surfaces*

**SA 2033**

Liquido di adesione per
materiale plastico

Adhesion liquid for plastic

**SA 2002**

Spray solvente per rimozione
collanti su superfici in acciaio
inox

*Solvent adhesive remover spray
for stainless steel surfaces*

**SA 3001**

Acido per ossidazione corten

Oxidising acid for corten

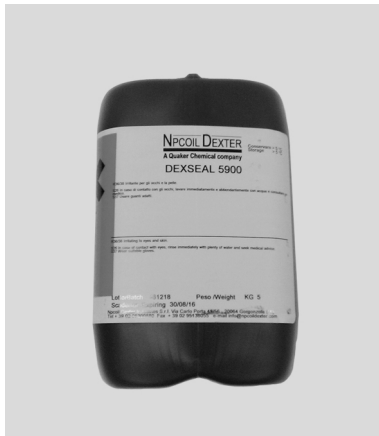
**SA 3002.25**

Passivante per ossidazione corten
25 Kg

*Passivating agent for corten
25 Kg*

SA 3002.05

Passivante per ossidazione corten
5 Kg

*Passivating agent for corten
5 Kg*

**SA 3003**

Cera d'api per finitura corten

Beeswax for Corten finishing

**SL 0019**

Sigillante a freddo per giunzione
angoli e traversi

*Cold sealant for corner and
transom joints*



1 kg

**SL 0021**

Silicone nero per guarnizioni

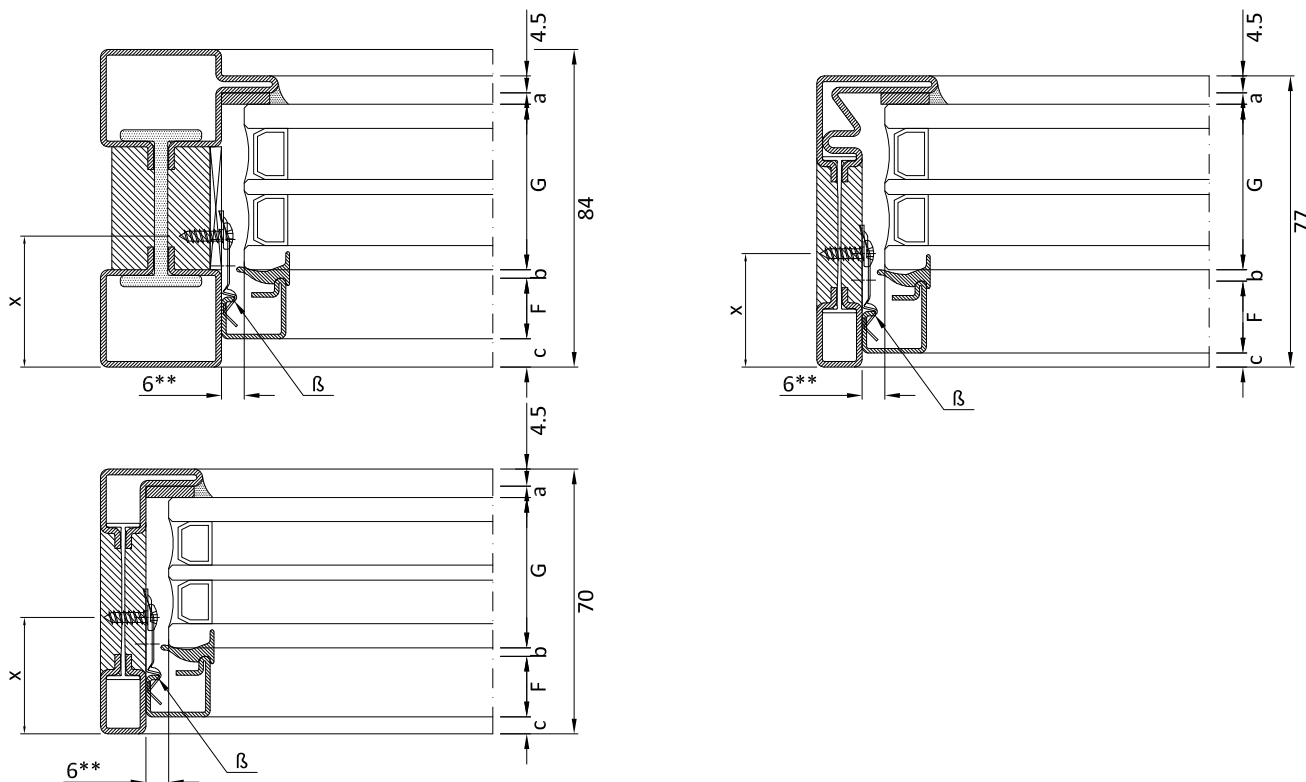
Black silicone for gaskets

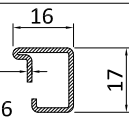
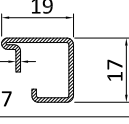
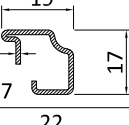
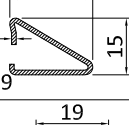
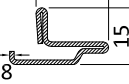

F	G			Guarnizioni - gasket		asse fissaggio viti fermavetro glazing beads securing axis			rientro fermavetro glazing beads gap			clips fissaggio fermavetro glazing beads securing clips	
	mm			a	b	Fisso 84 Fix 84	Fisso 77 Fix 77	Fisso 70 Fix 70	Fisso 84 Fix 84	Fisso 77 Fix 77	Fisso 70 Fix 70		β
fermavetro glazing beads codice code				GU2036 3 mm  + sigillatura + seal	GP0095 2 / 3 mm 	x			c				
						Fisso 84 Fix 84	Fisso 77 Fix 77	Fisso 70 Fix 70	Fisso 84 Fix 84	Fisso 77 Fix 77	Fisso 70 Fix 70		
 PR2606	35	35	35	3	3	41	34 *	34	15	15	8	AC2608	
	-	-	-			19 *	26	26	0	0	0		
 PR2607	34	34	34			39	32 *	32	13	13	6	AC2608	
	-	-	-			19 *	26	26	0	0	0		
 PR2627	34	34	34			39	32 *	32	13	13	6	AC2608	
	-	-	-			19 *	26	26	0	0	0		
 PR2629	34	34	34	40 *	40 *	33 *	10	10	3	AC2608			
	-	-	-	37	30 *	37	0	0	0				
 PR2638	35	35	35	46 *	46 *	39 *	12	12	5	AC2608			
	-	-	-	41	34 *	34 *	0	0	0				

* fissare tramite il primo foro della clip
* screw in the first hole of the clip

** 7 mm per PR2638
** 7 mm for PR2638

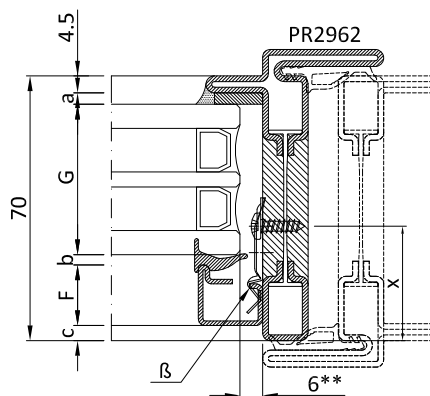
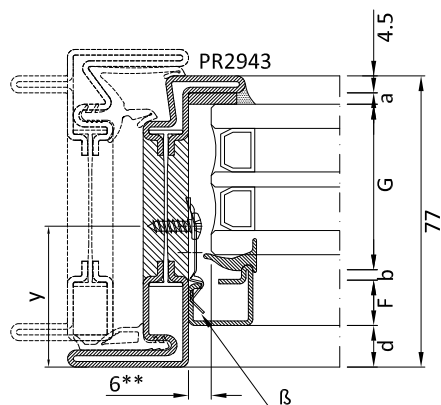



F	G	Guarnizioni - gasket		asse fissaggio viti fermavetro glazing beads securing axis		rientro fermavetro glazing beads gap		boccole e viti fissaggio fermavetro Bushings and screws for fixing of glazing bead			
		GU2036 3 mm + sigillatura + seal	GP0095 2 / 3 mm						a	b	x
fermavetro glazing beads	spessore vetro glass thickness										
codice code	mm										
PR2606 	34 - 43	3	3	35	42	9	16	AC2608			
				-	-	-	-		-	-	
				26	33	0	7				
PR2607 	34 - 40			32	39	6	13		AC2608		
				-	-	-	-			-	-
				26	33	0	7				
PR2627 	34 - 40	32	39	6	13	AC2608					
		-	-	-	-		-	-			
		26	33	0	7						
PR2629 	34 - 37	40	47	3	10		AC2608				
		-	-	-	-			-	-		
		37	44	0	7						
PR2638 	38 - 40	39	46	2	9	AC2608					
		-	-	-	-			-	-		
		41	48	0	7						

** 7 mm per PR2638

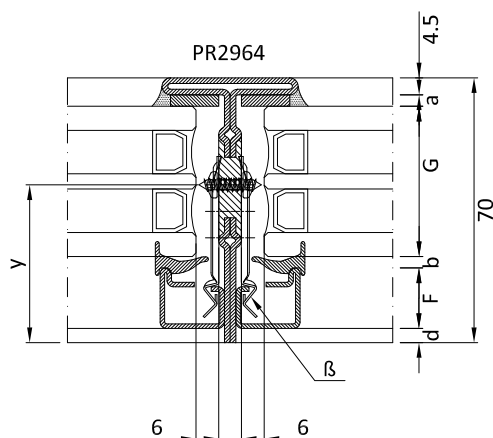
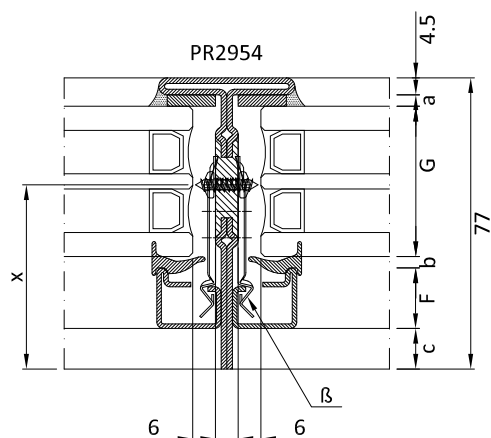
** 7 mm for PR2638

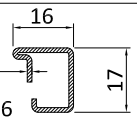
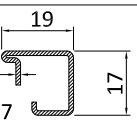
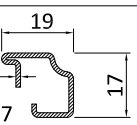
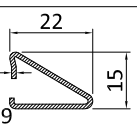
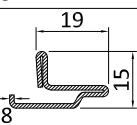

F	G		Guarnizioni - gasket		asse fissaggio viti fermavetro glazing beads securing axis		rientro fermavetro glazing beads gap		boccole e viti fissaggio fermavetro Bushings and screws for fixing of glazing bead
	fermavetro glazing beads	spessore vetro glass thickness		GU2036 3 mm  + sigillatura + seal	GP0095 2 / 3 mm 	x	y	c	
codice code	Fisso 77 Fix 77	Fisso 70 Fix 70	a	b					β
PR2606 	34 - 50!!	34 - 43	3	3	54 - 24	48 - 38	16 - 0	10 - 0	AC2609AR
PR2607 	31 - 47	31 - 40			54 - 24	48 - 38	16 - 0	10 - 0	AC2609AR
PR2627 	31 - 47	31 - 40			54 - 24	48 - 38	16 - 0	10 - 0	AC2609AR
PR2629 	36 - 45	36 - 38			51 - 42	44 - 42	9 - 0	2 - 0	AC2609AR
PR2638 	43 - 48	43 - -			44* - 46	39* - -	9 - 0	0 - -	AC2609AR

* fissare tramite il primo foro della clip

* screw in the first hole of the clip

*** fissare tramite il terzo foro della clip

*** screw in the third hole of the clip

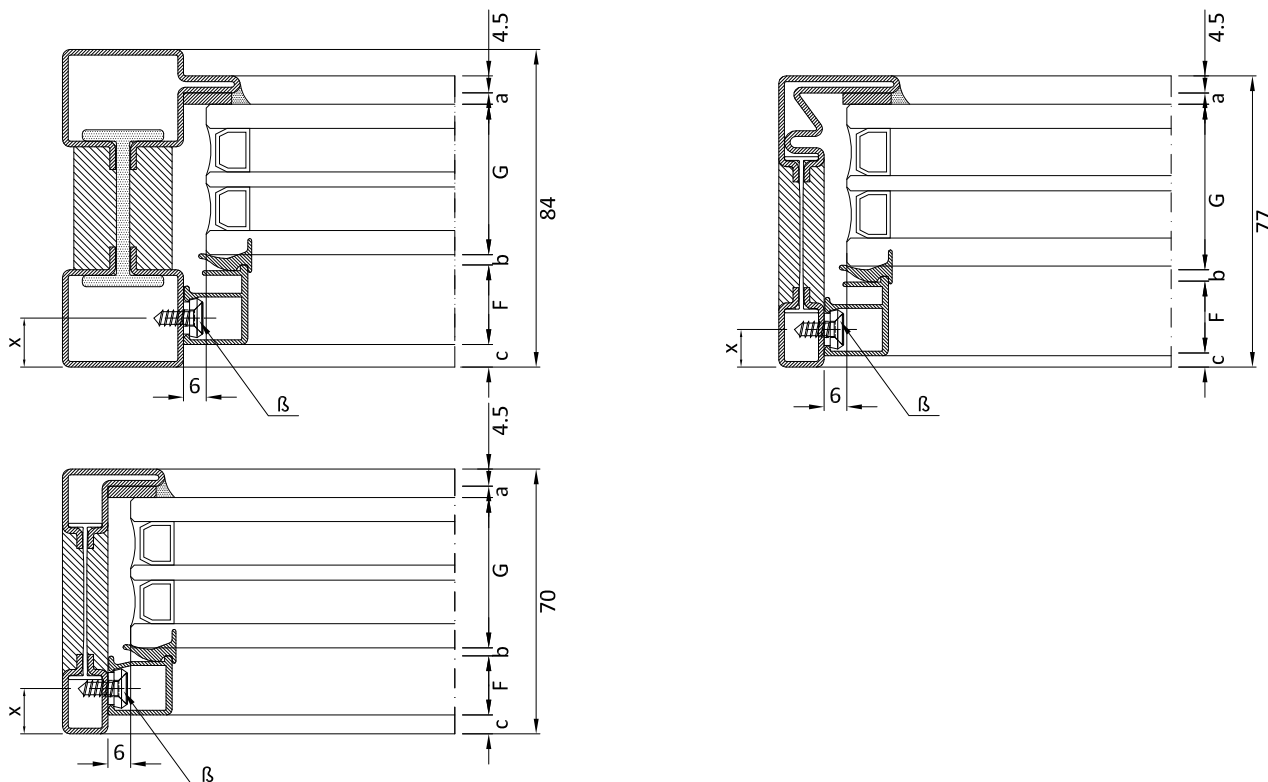

!! da 47 a 50 mm fissare tramite il primo foro della clip con rondella di spessoramento da 1 mm

!! from 47 to 50 mm fix through the first hole of the clip with shim washer of 1 mm

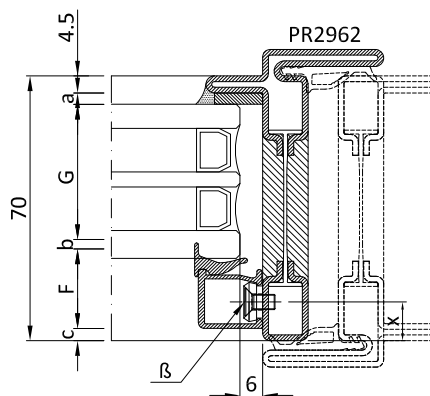
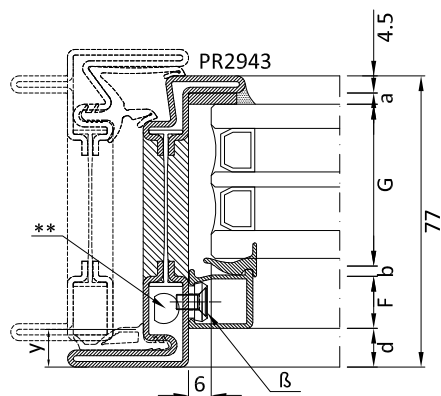

F	G			Guarnizioni - gasket		asse fissaggio viti fermavetro glazing beads securing axis			rientro fermavetro glazing beads gap			boccole e viti fissaggio fermavetro Bushings and screws for fixing of glazing bead
	spessore vetro glass thickness			GU2036 3 mm + sigillatura + seal	GP0095 2 / 3 mm	x			c			
codice code	mm			a	b	Fisso 84 Fix 84	Fisso 77 Fix 77	Fisso 70 Fix 70	Fisso 84 Fix 84	Fisso 77 Fix 77	Fisso 70 Fix 70	β
PA2606	38 - 51	45 - 51	38 - 44	3	3	20 - 7	13 - 7	13 - 7	13 - 0	6 - 0	6 - 0	CV1023(i) CV5012(i)
PA2607	34 - 45	39 - 45	32 - 38			18 - 7	13 - 7	13 - 7	11 - 0	6 - 0	6 - 0	CV1023(i) CV5012(i)
PA2608	28 - 39	33 - 39	--			18 - 7	13 - 7	--	11 - 0	6 - 0	--	CV1023(i) CV5012(i)

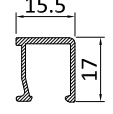
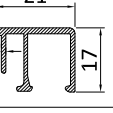
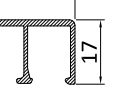

F	G	Guarnizioni - gasket		asse fissaggio viti fermavetro glazing beads securing axis		rientro fermavetro glazing beads gap		boccole e viti fissaggio fermavetro Bushings and screws for fixing of glazing bead
		GU2036 3 mm  + sigillatura + seal	GP0095 2 / 3 mm 	x	y	c	d	
fermavetro glazing beads	spessore vetro glass thickness	a	b					β
codice code	mm							
PA2606 	40	3	3	11	18	4	11	CV1243(i) CV5012(i)
	- 44			7	14	0	7	
PA2607 	34					11	18	4
	- 38			7	14	0	7	
PA2608 	32			7	14	0	7	CV1243(i) CV5012(i)

* Fare attenzione al fissaggio fermavetro in prossimità kit cremone - vedi pg. 2.9.13

* Pay attention fixing the screw near cremone set - see pg. 2.9.13

Fissaggio fermavetri PR2606 - PR2607 - PR2627 - PR2629: clip AC2608/AC2609 con vite TC 3.5 x 9.5 (non fornite)
 Glazing beads fixing PR2606 - PR2607 - PR2627 - PR2629: clip AC2608 /AC2609 with screw TC 3.5 x 9.5 (not included)

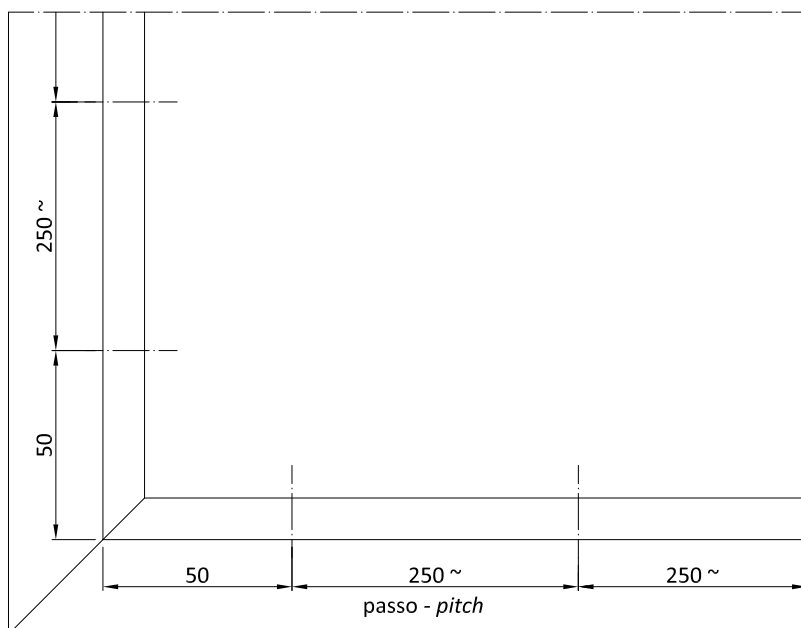

Passo clips fissaggio fermavetri
 Clip pitch for glazing beads securing

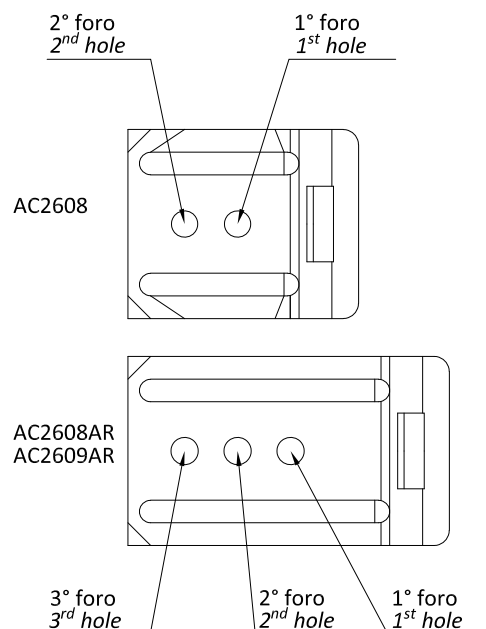

Fissaggio fermavetri PA2607 - PA2608: profili telaio vite CV1023(I) TPS 4,2 x 13 e boccola CV5012(I)
 Profili anta vite CV1243(I) TPS M4 x 8 e boccola CV5012(I).
 Glazing bead fixing PA2607 - PA2608: frame profile screw CV1023(I) TPS 4,2 x 13 and bushing CV5012(I)
 Leaf profile screw CV1243(I) TPS M4 x 8 M4 x 8 and bushing CV5012(I).

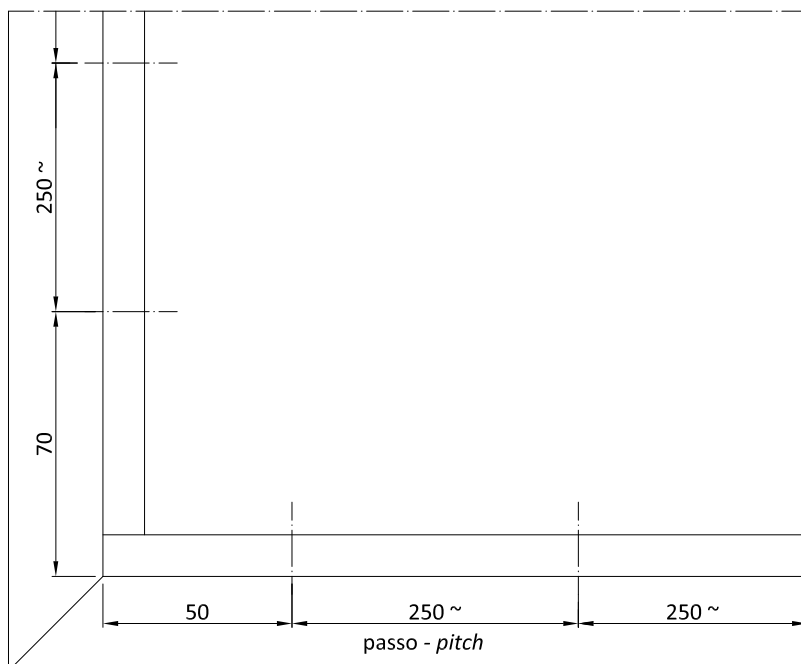

Passo vite e boccola fissaggio fermavetri
 Screw and bushing pitch for glazing beads fixing

Boccole fissaggio fermavetri in alluminio
Bushing fixing for aluminium glazing beads

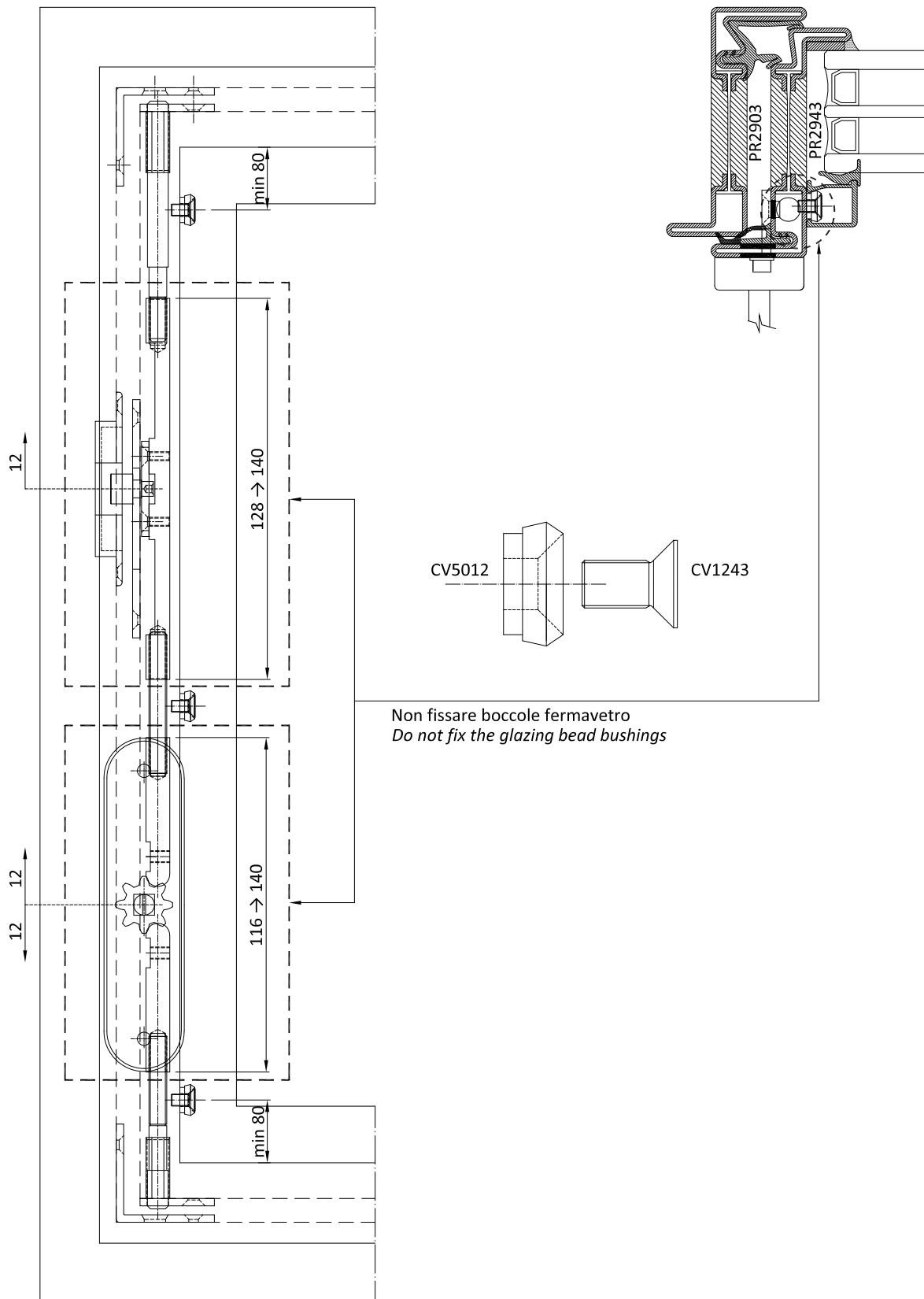

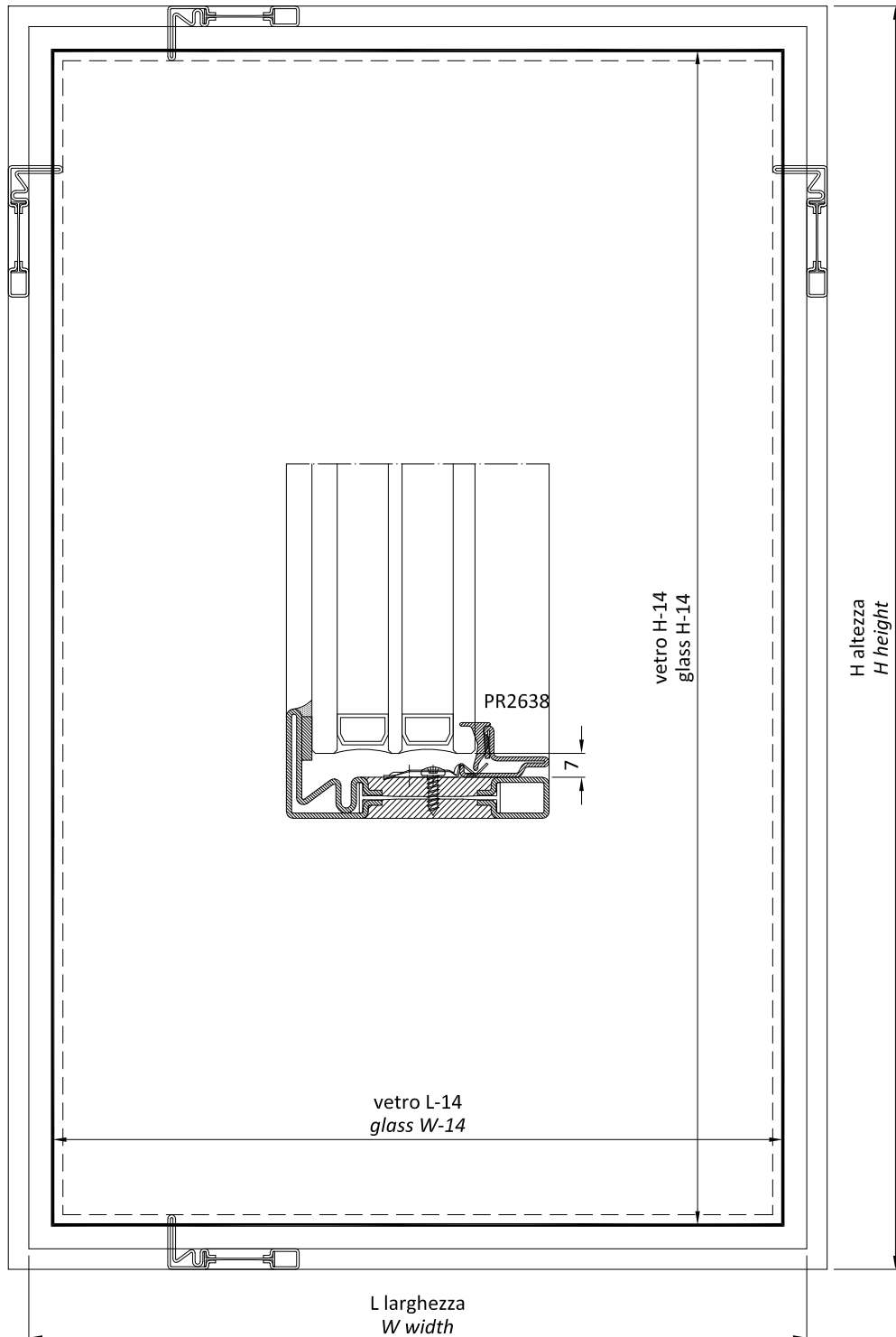
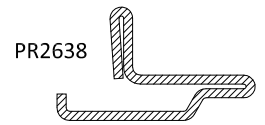

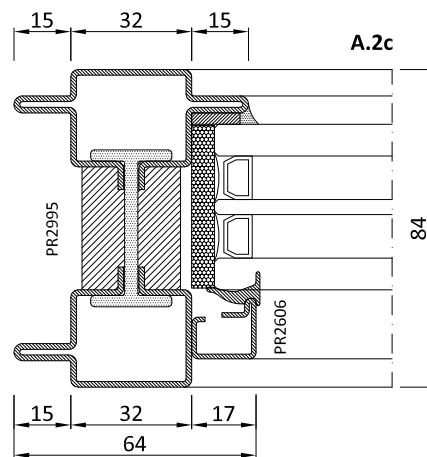
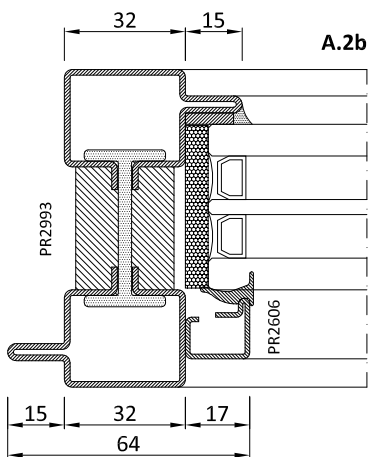
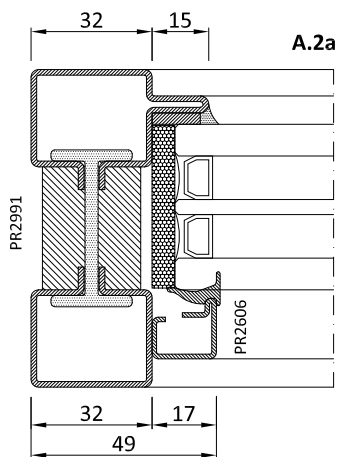
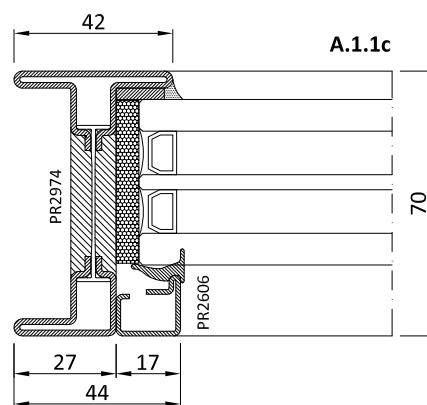
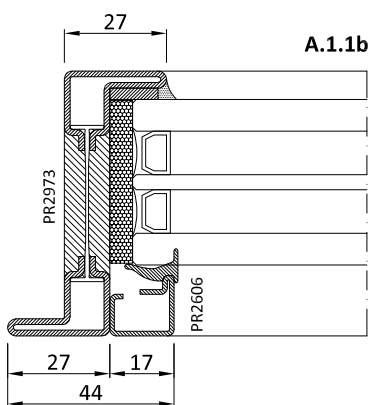
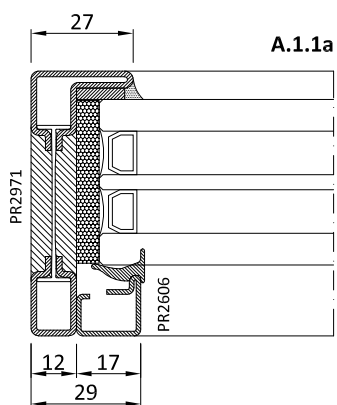
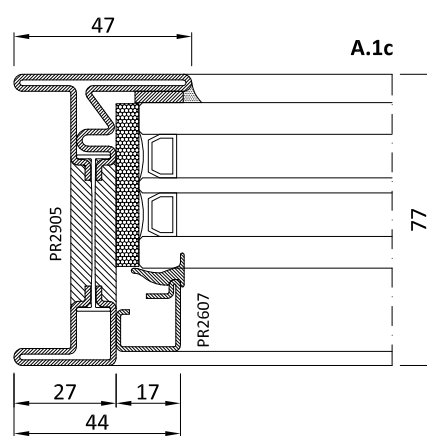
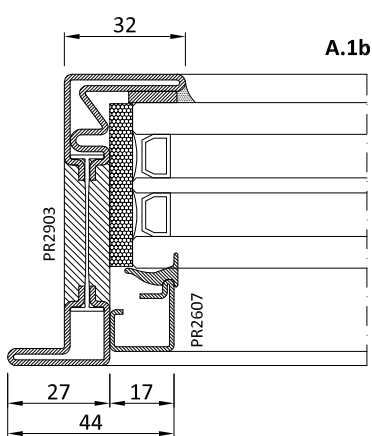
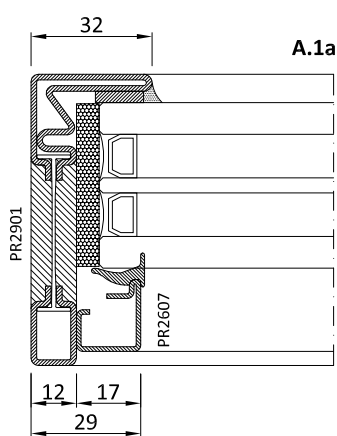
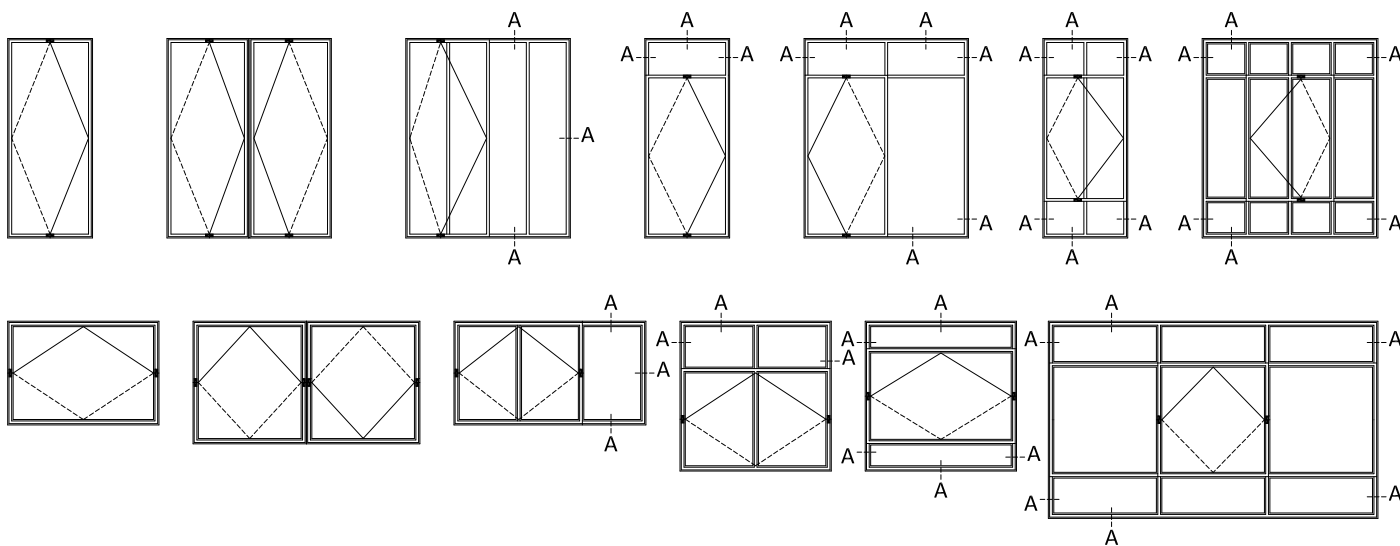

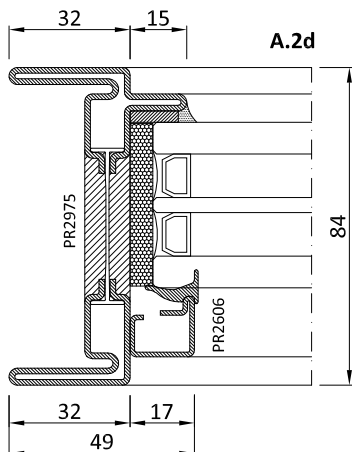
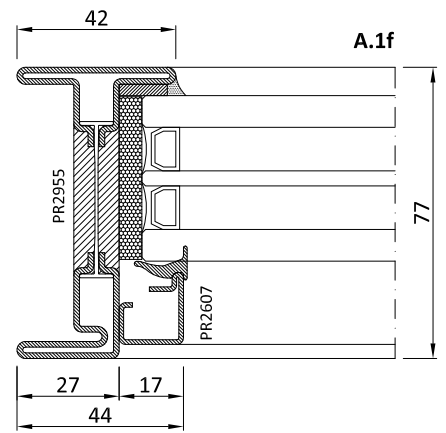
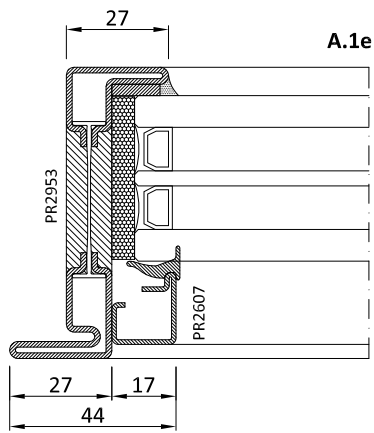
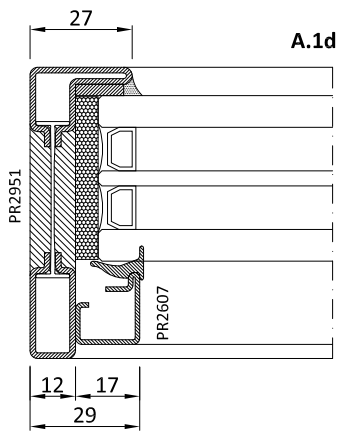
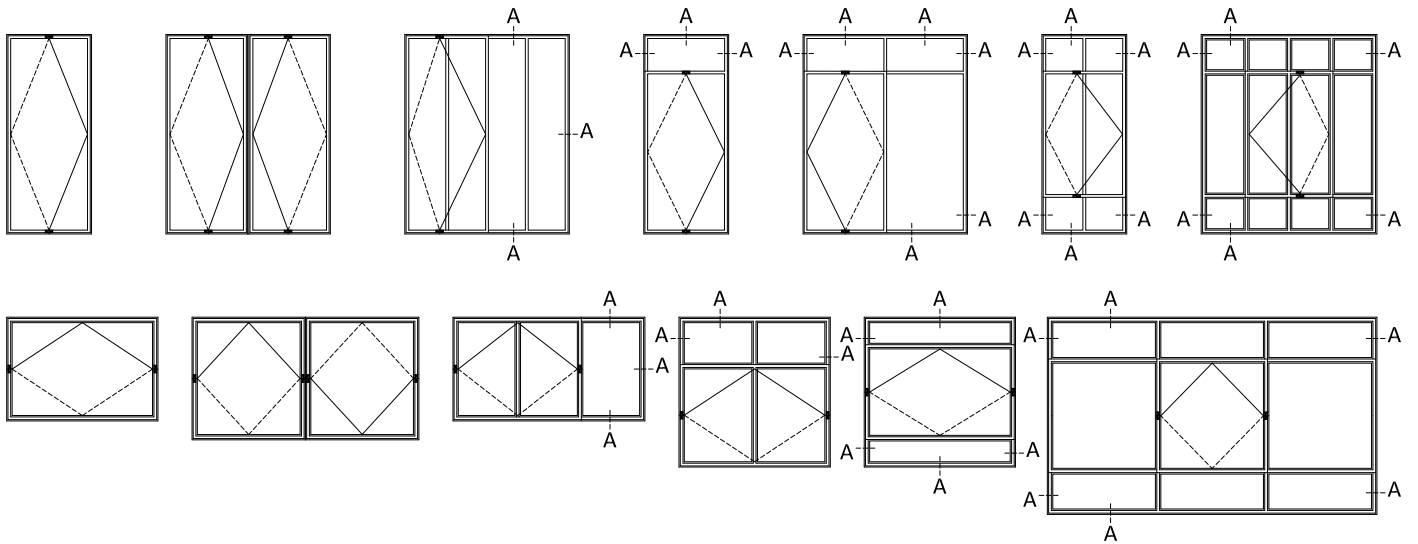

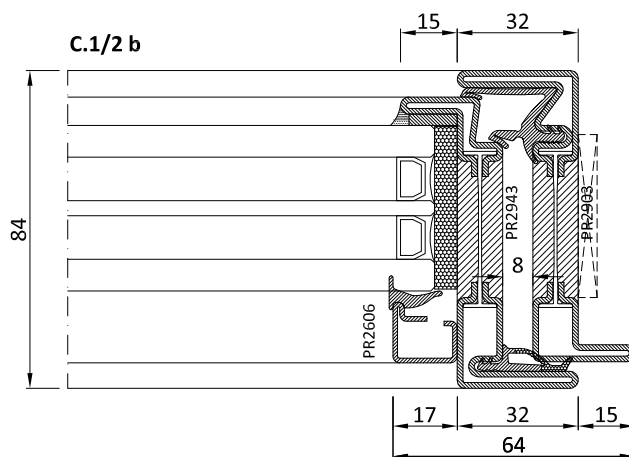
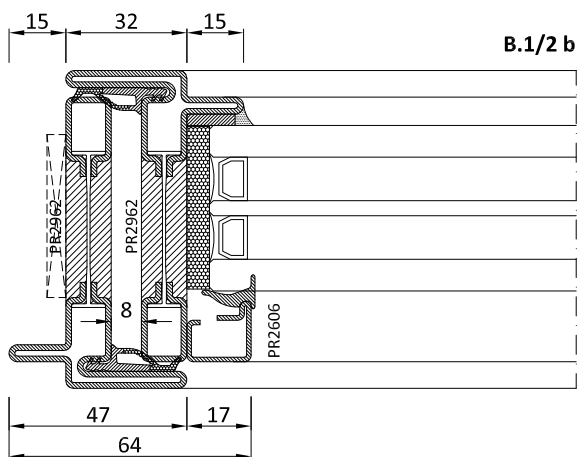
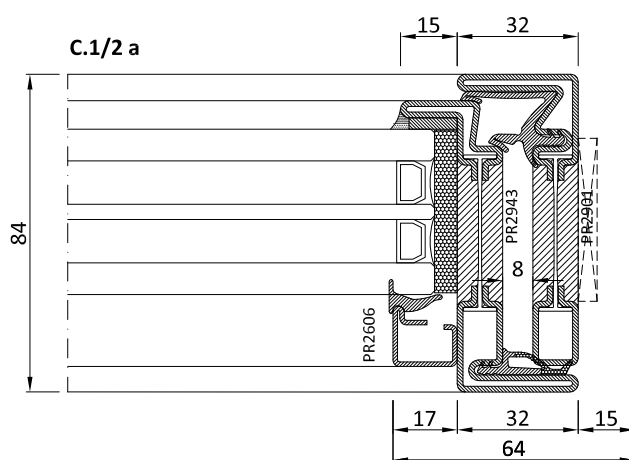
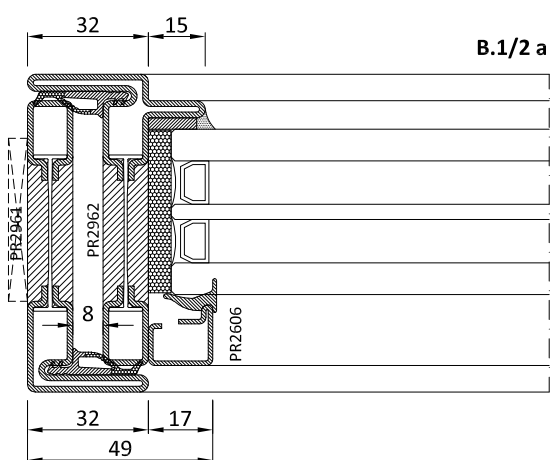
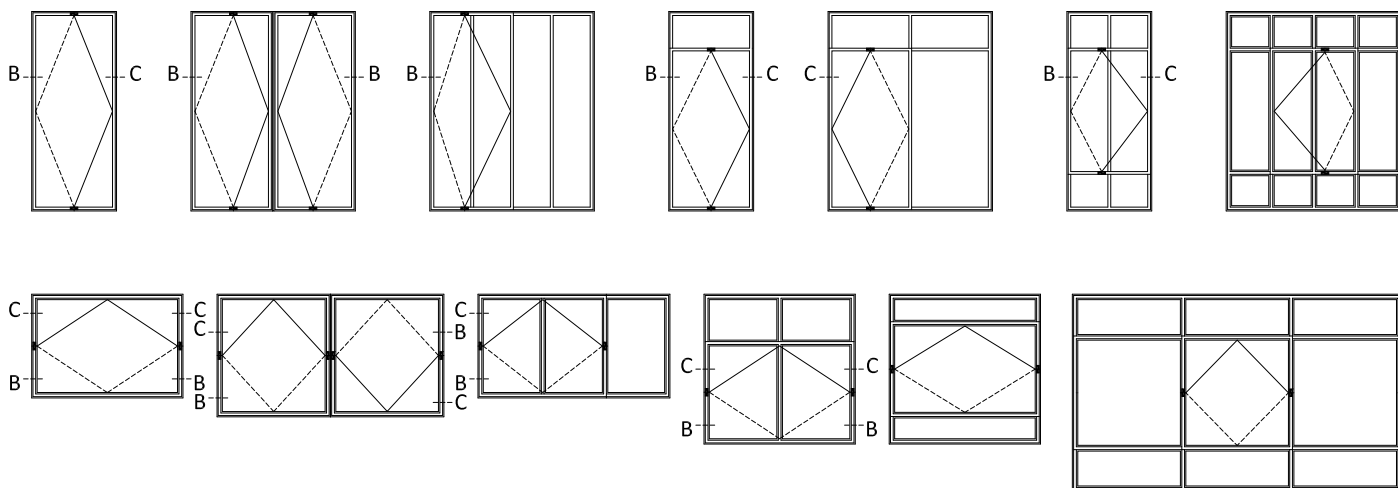

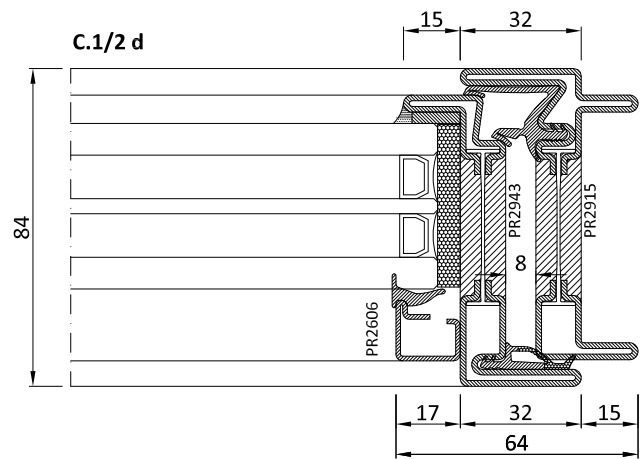
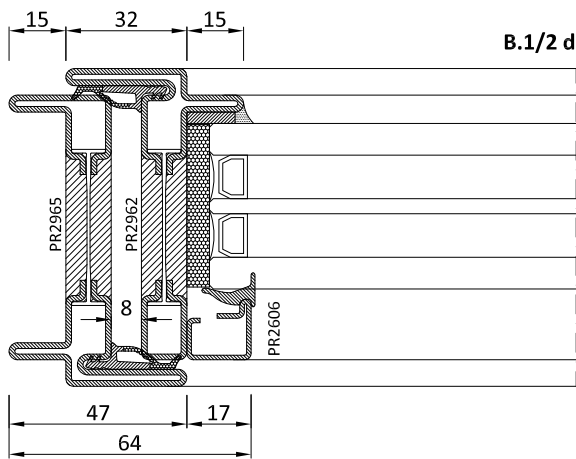
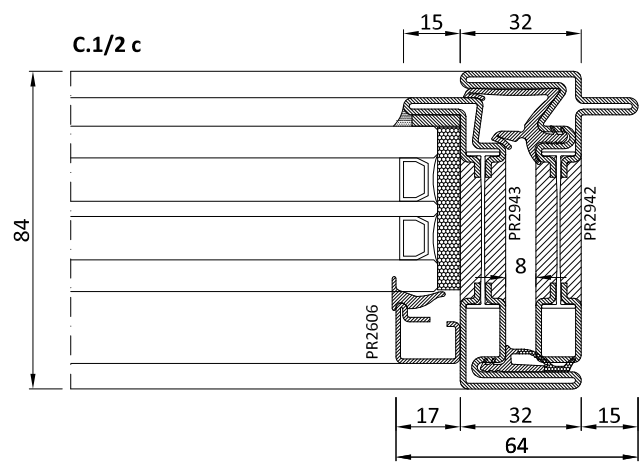
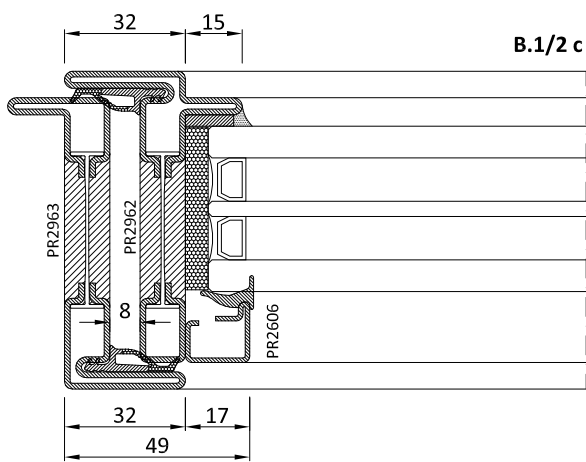
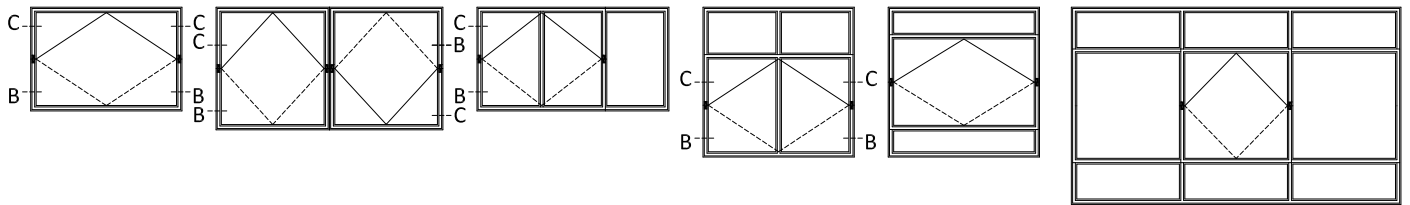
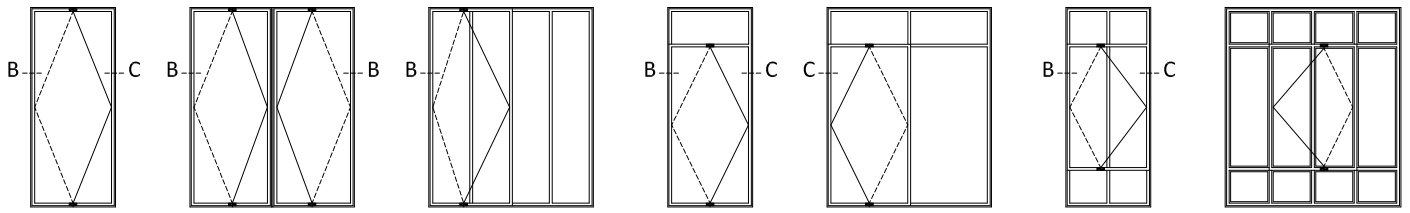

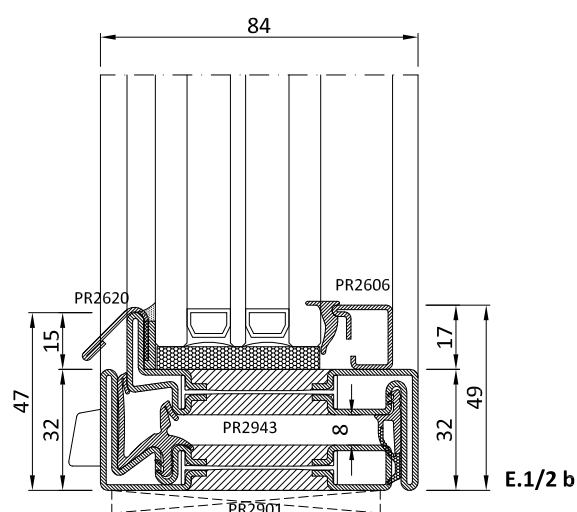
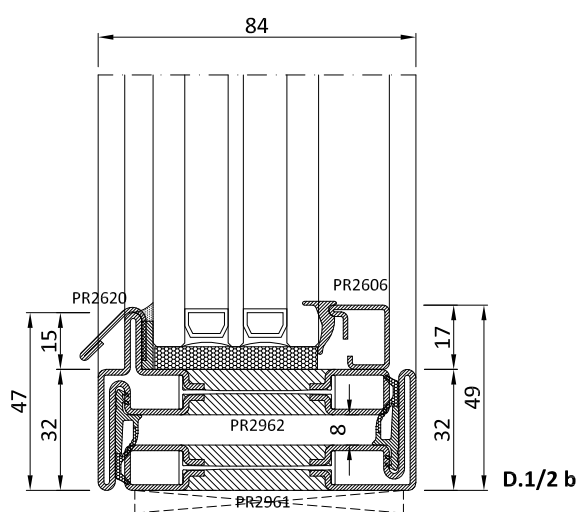
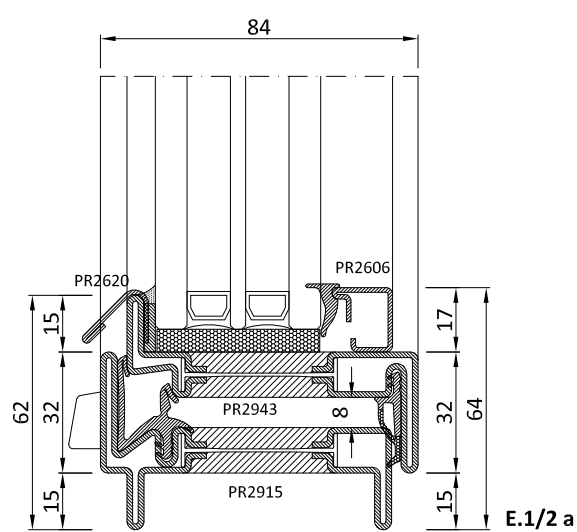
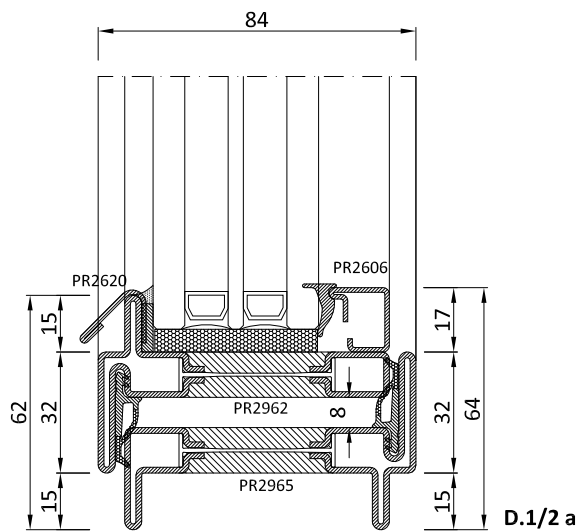
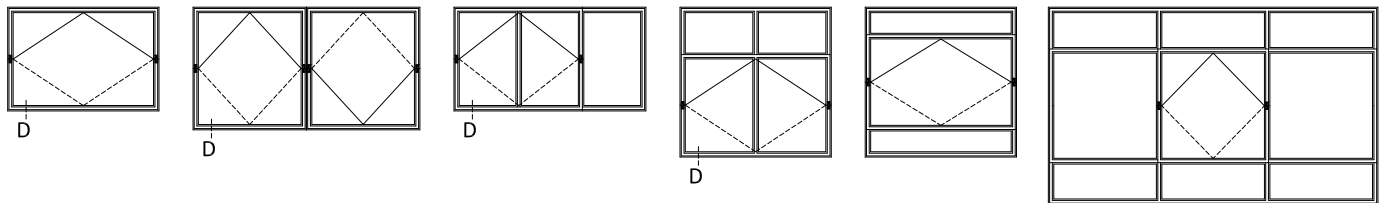
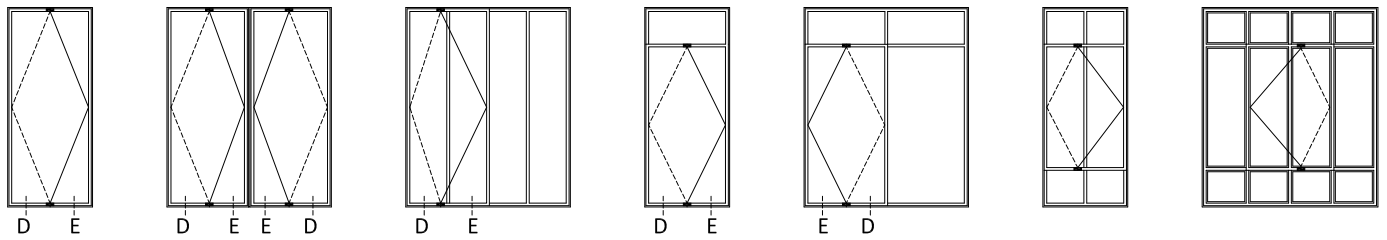

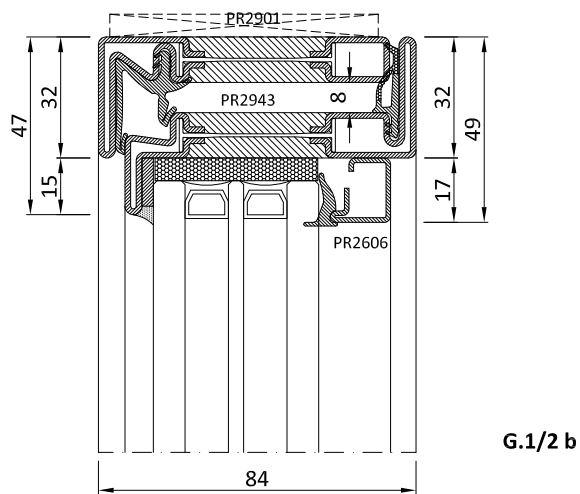
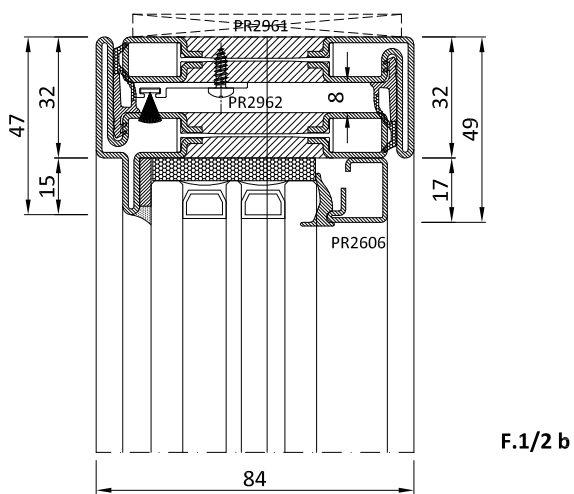
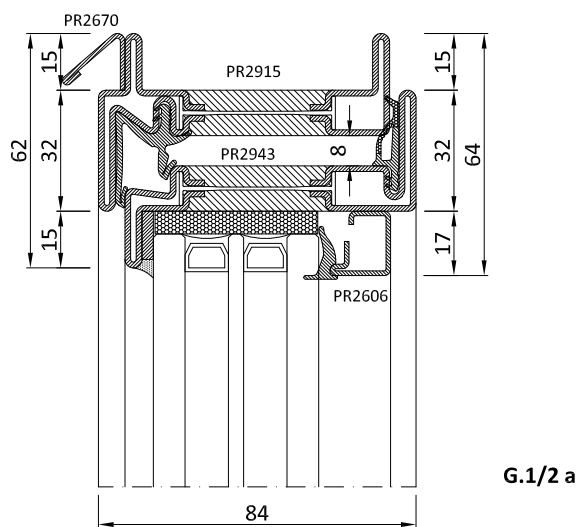
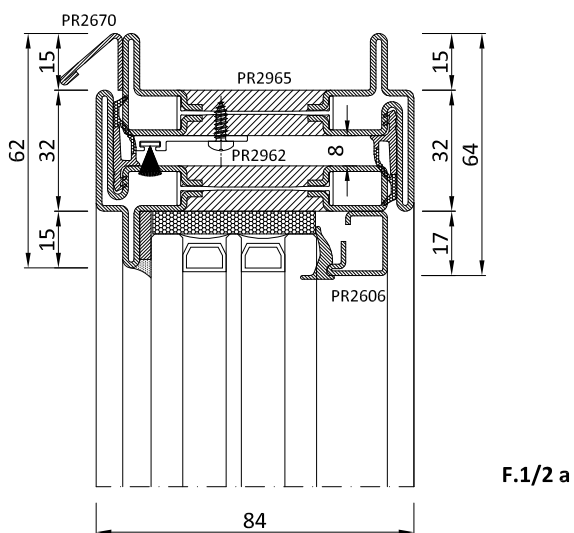
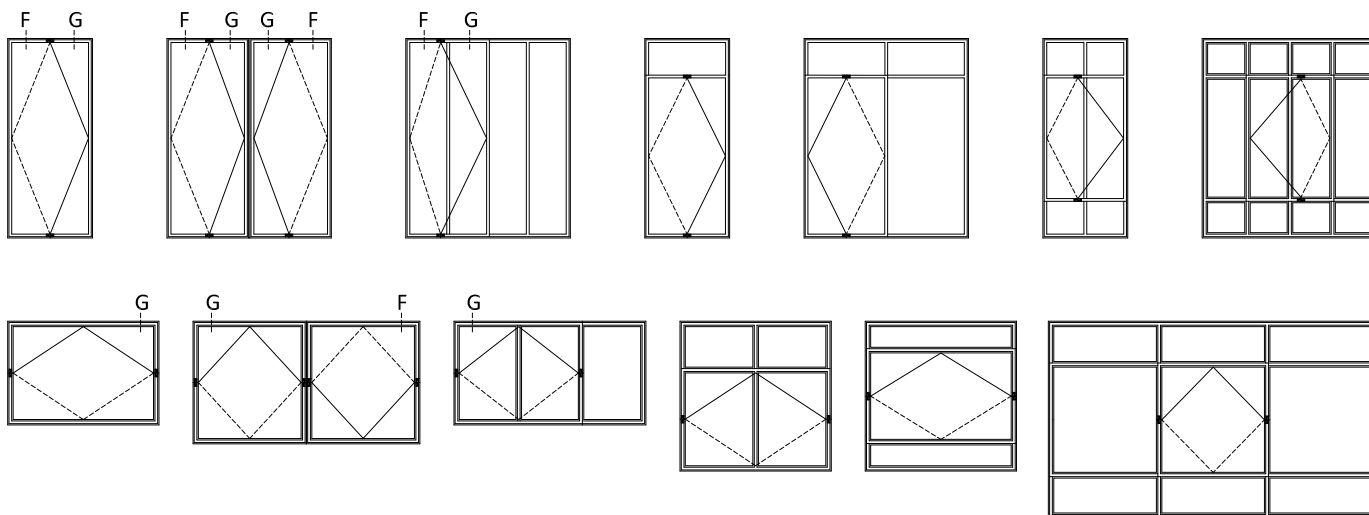

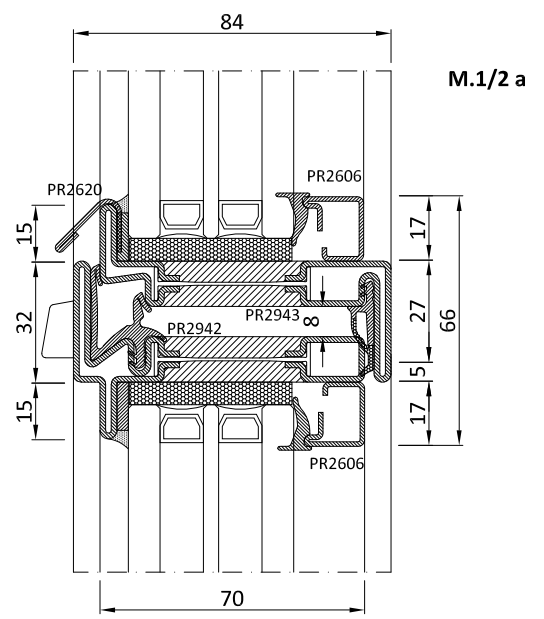
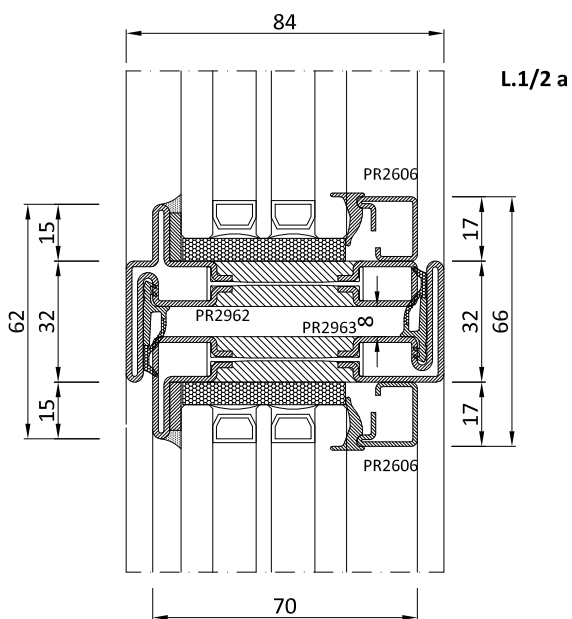
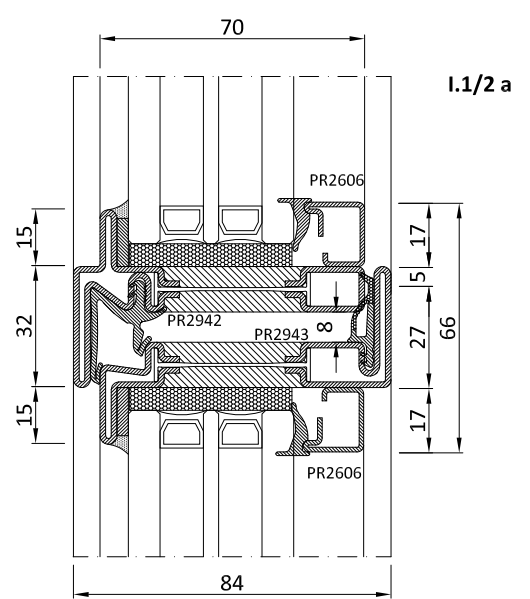
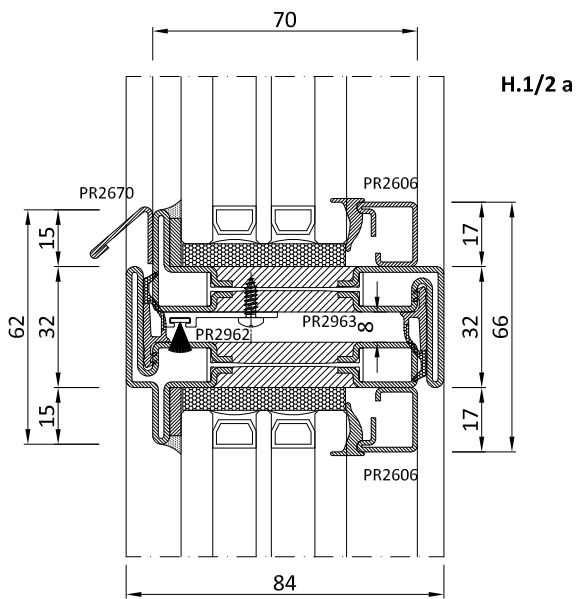
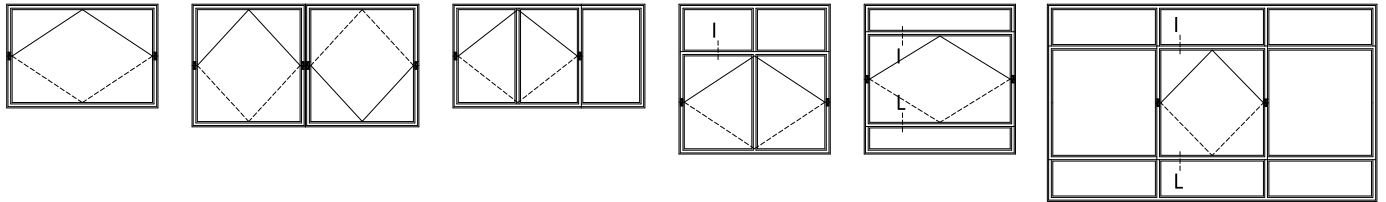
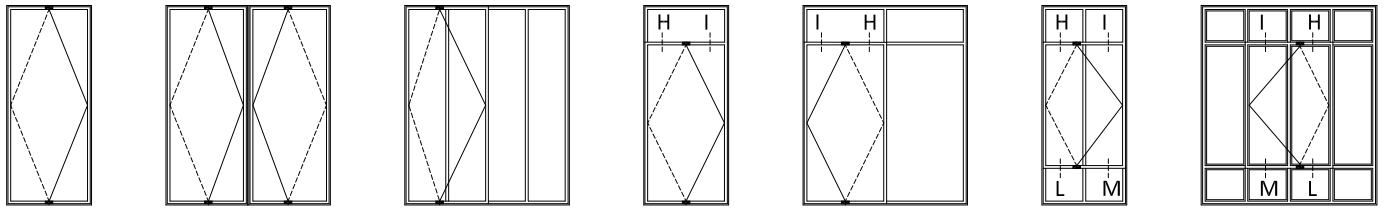

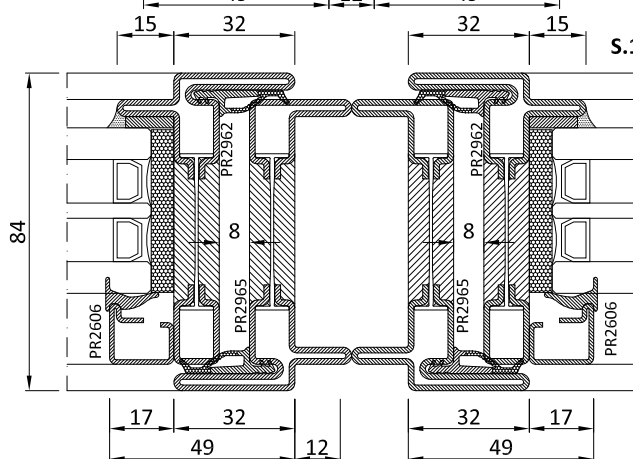
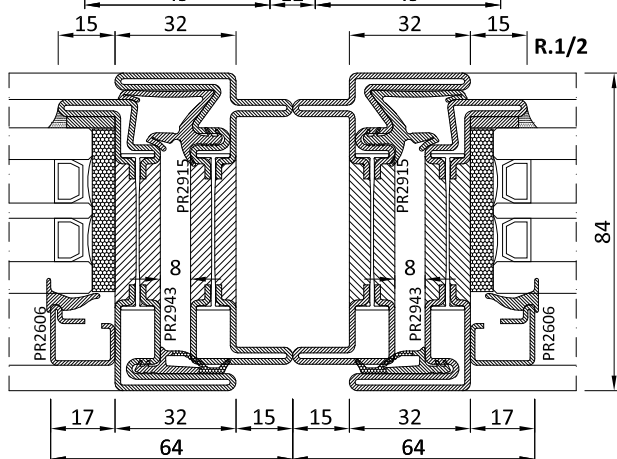
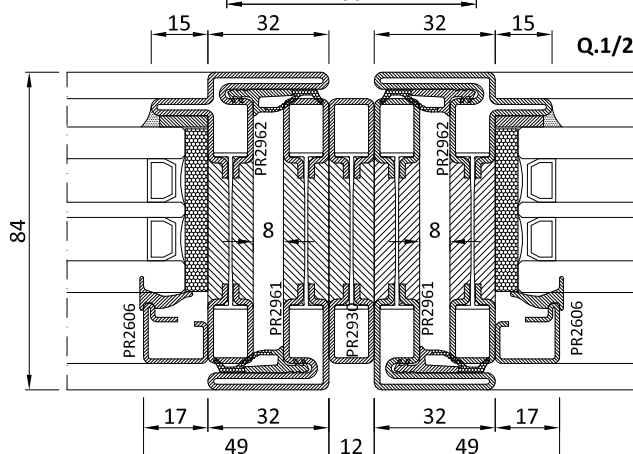
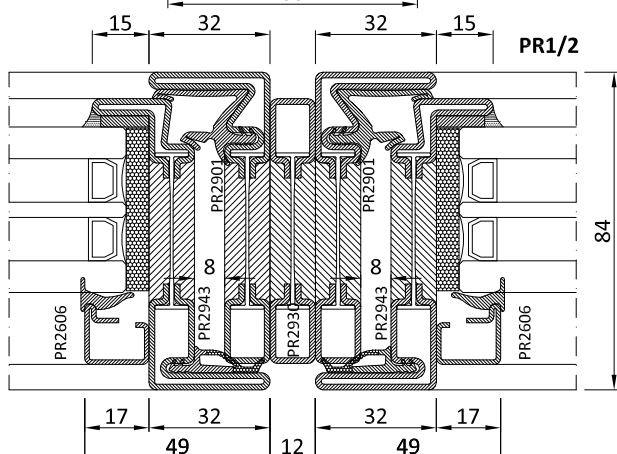
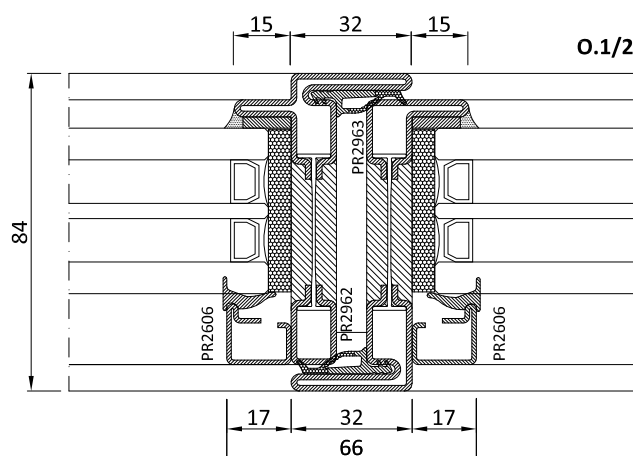
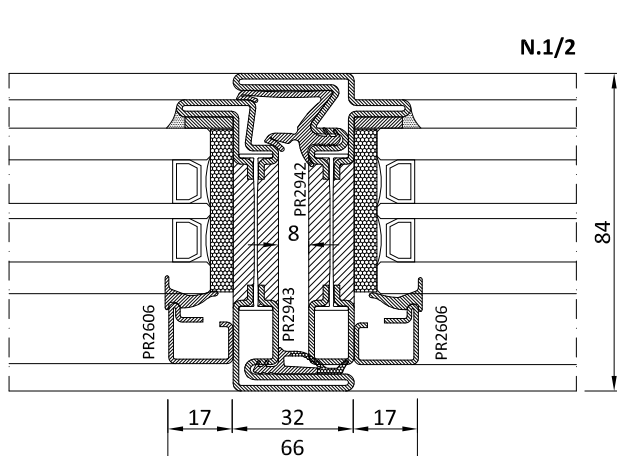
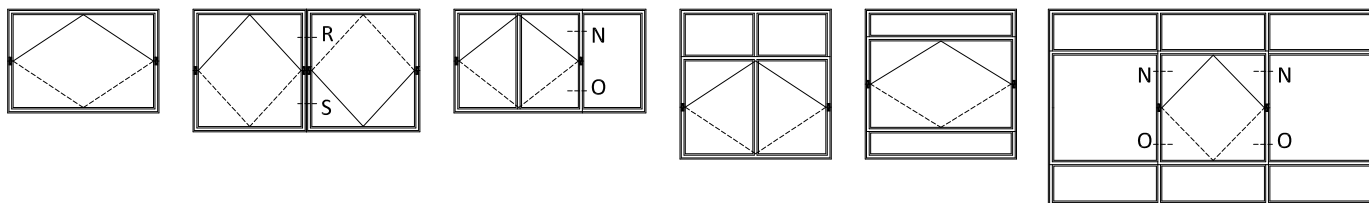
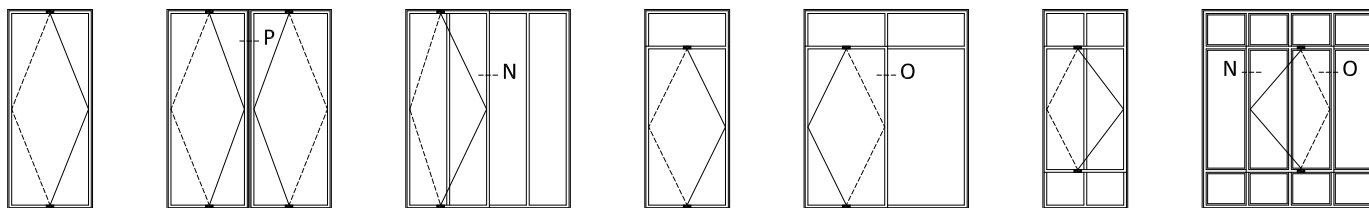

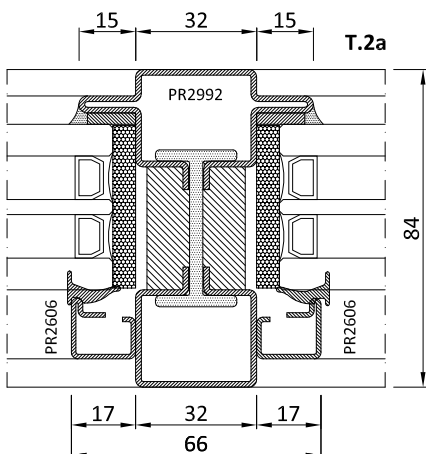
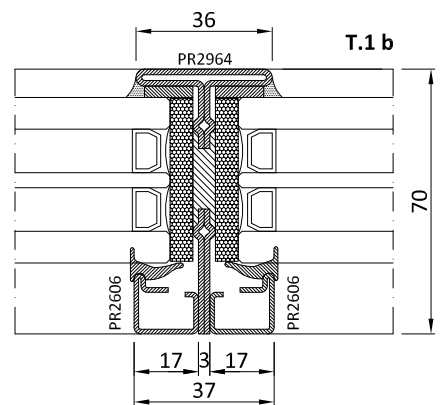
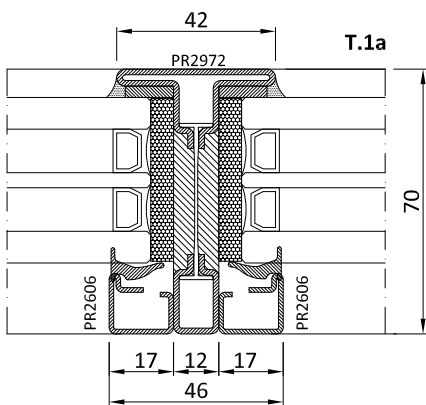
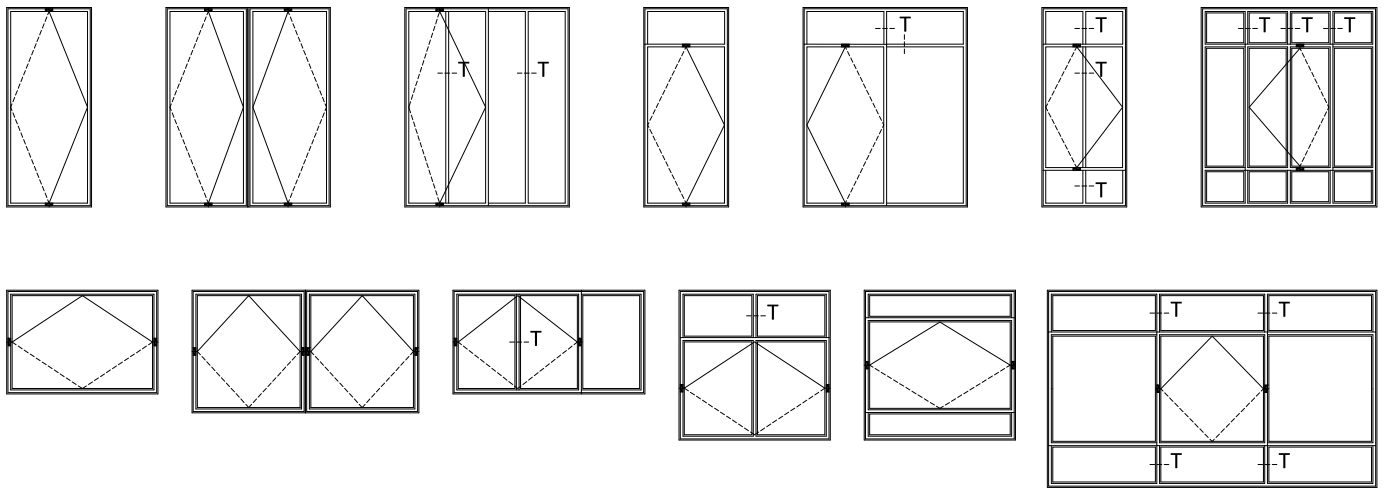

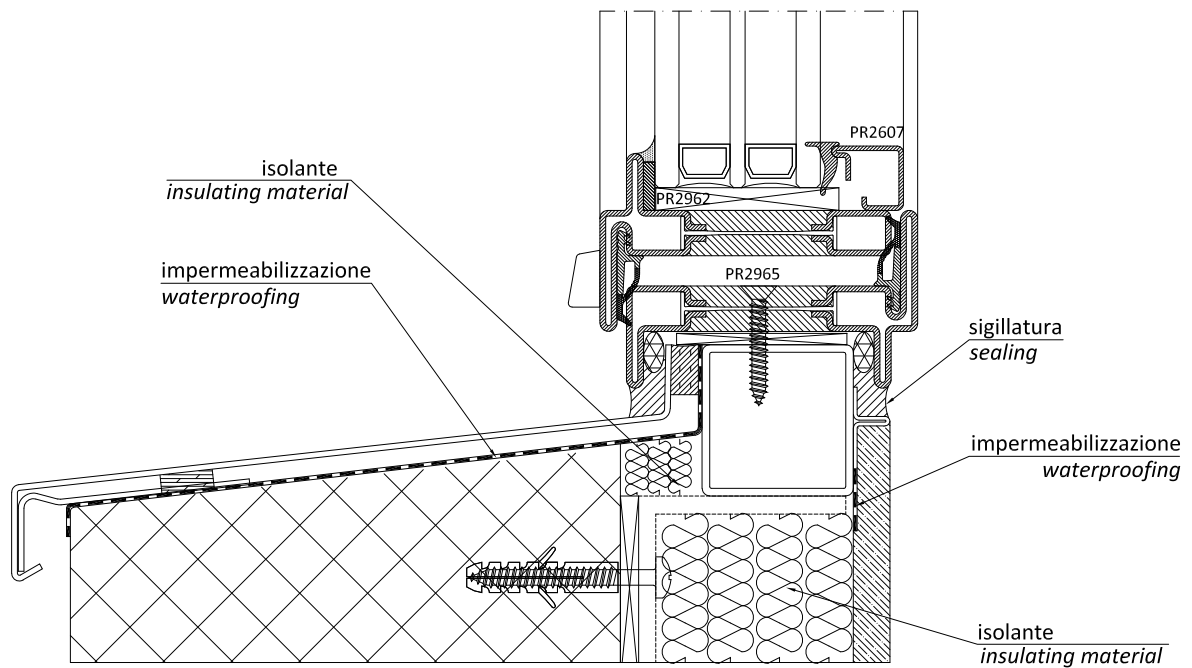
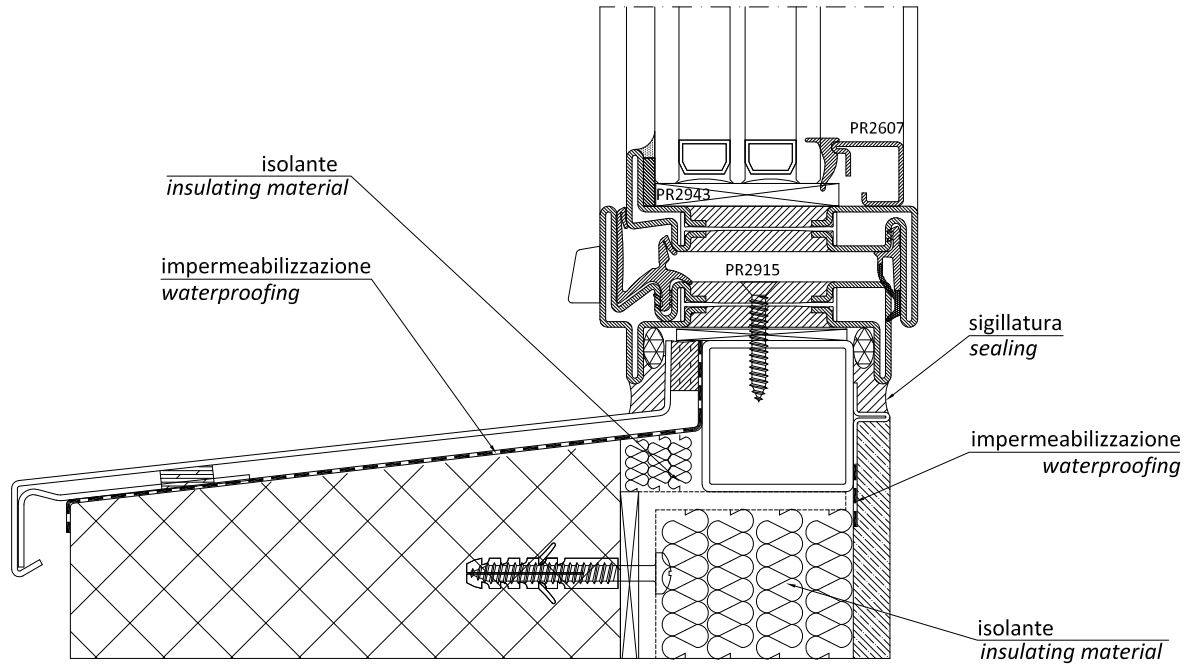

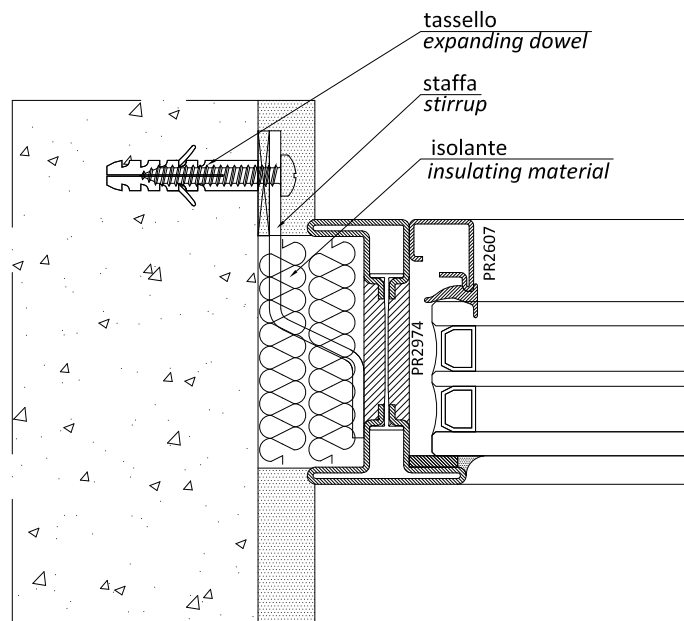
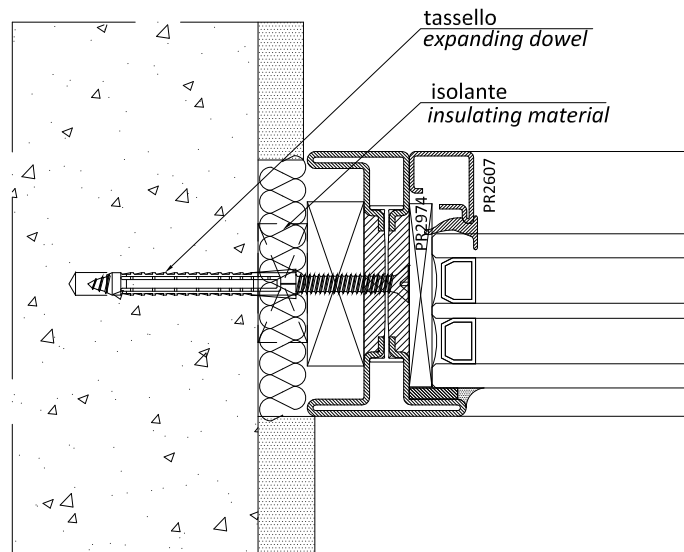

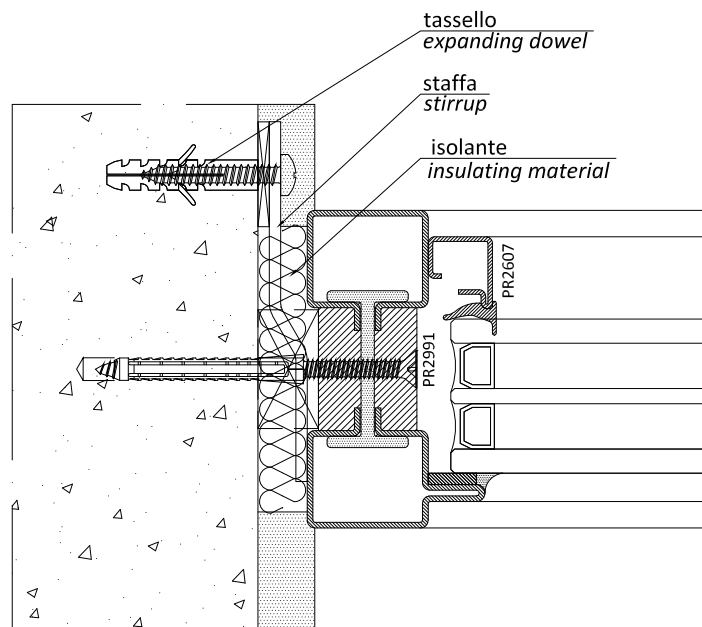
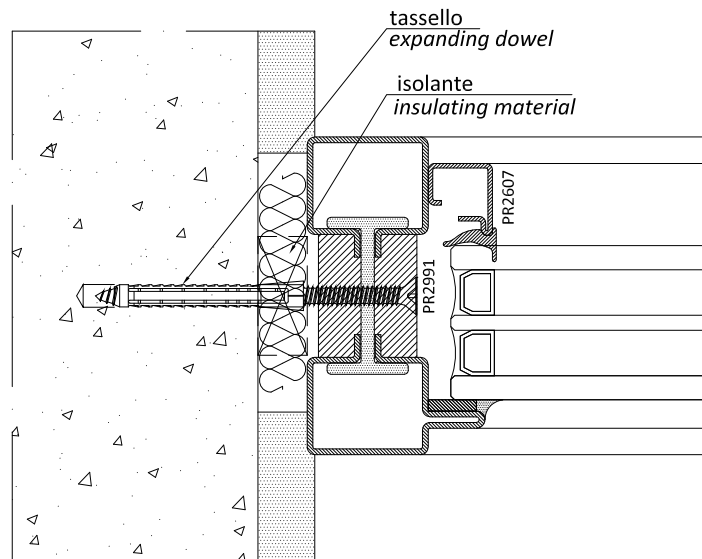

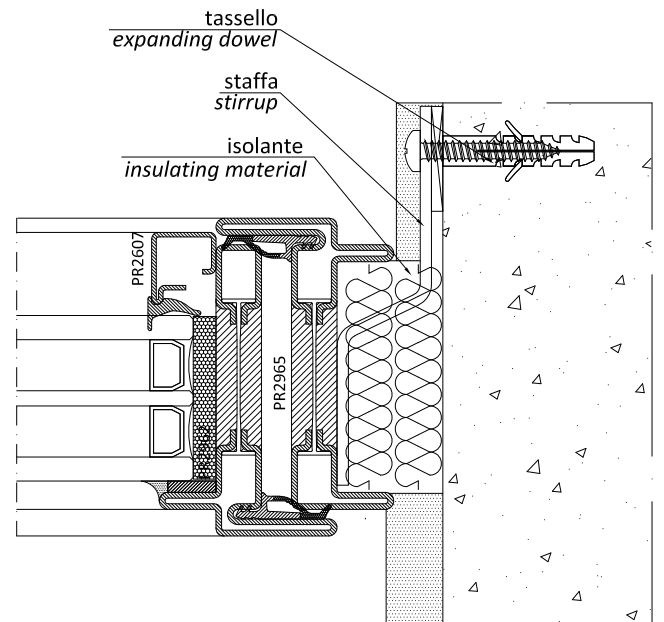
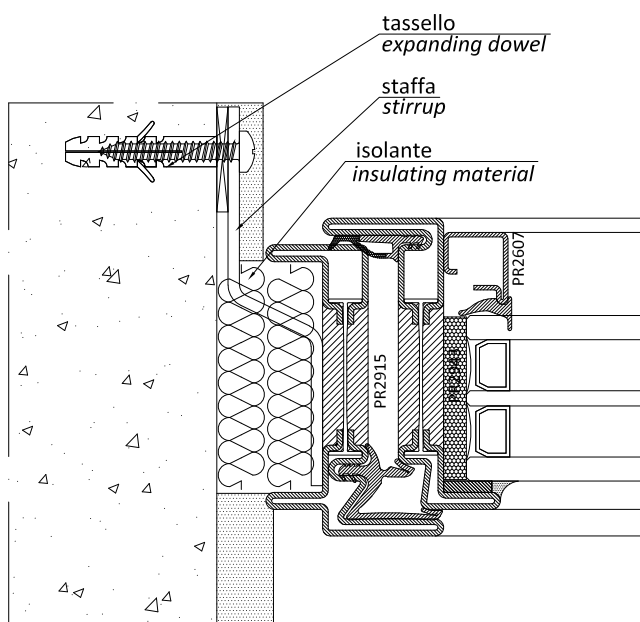
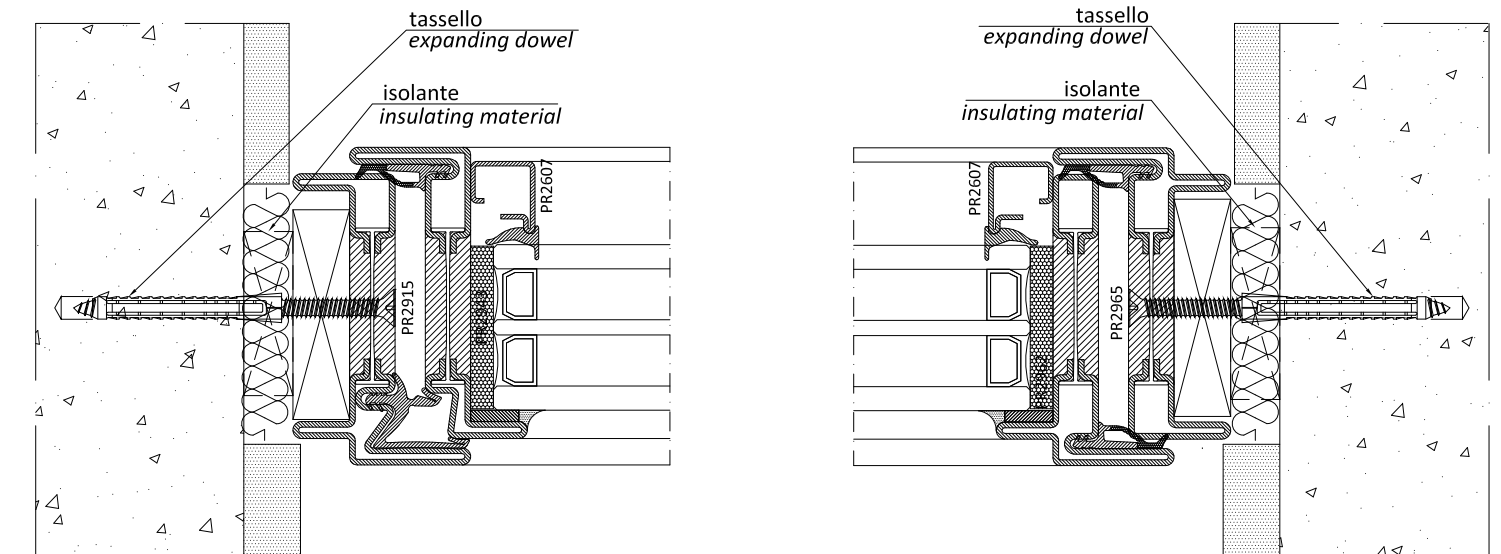

Lavorazioni su barra / Section working

Taglio / Cut	5.1.1-2 5.2.1-2
Fori e asole per cremonese / Cremonese bolt holes and slots	4.3.7-9
Fori e asole per chiusura supplementare / Additional locking points slots and holes	4.3.10-11
Fori per scarico acqua / Water drip holes	4.3.4
Lavorazione inserimento snodo bilico / Working for pivot bearing	4.3.12-15
Lavorazione gocciolatoio / Water drip section workink	4.3.5
Fori fissaggio a muro / Wall mounting holes	3.2.1-4

Assiemaggio / AssemblyCostruzione telai / Frame assembly

Saldatura / Welding	4.4.2-5
Inserimento squadrette (profili ottone) / Brackets insertion (brass section)	4.4.1-2
<u>Applicazione accessori / Accessories installation</u>	
Assiemaggio snood bilico / Pivot bearing assembling	4.4.6-18
Sequenza di assiemaggio / Assembling sequence	4.4.19

Preparazione per verniciatura e ossidazione / Preparation for the powder coating - burnishing

Fori su telaio per scarichi liquidi pretrattamento / Holes on frame for the drainage of pretreatment liquid	5.1.4
Pulitura della superficie (ottone) / Cleaning of the surface	5.1.4-5

Montaggio accessori / Accessories installation

Applicazione e sigillatura guarnizioni giunto aperto / Sealing of central gasket	4.5.1
Applicazione scarichi acqua / Water drip installation	4.5.1
Montaggio cremonese e incontri / Cremonese bolt installion	4.5.2-6
Sigillatura angolo nel TT / Corner joint sealing	4.5.1

Vetrazione / Glazing

Applicazione clips fermavetro / Glazing bead clips installation	2.8.1-8
Applicazione vetro (spessoramento) / Glazing installation (setting blocks)	4.6.1

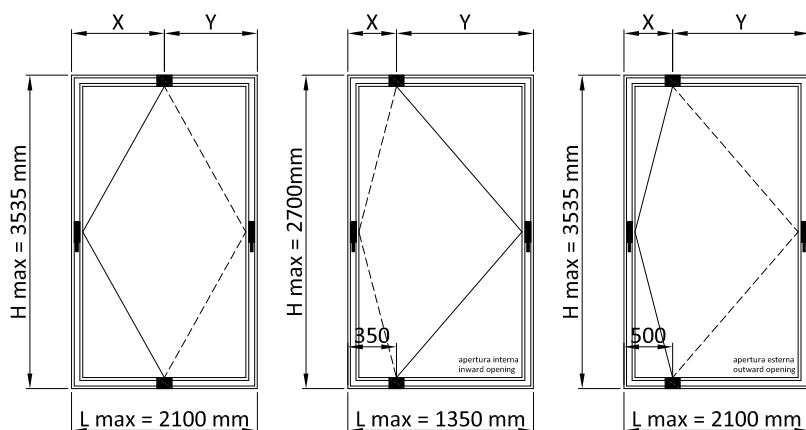

PROFILI <i>PROFILES</i>						
Codice <i>Code</i>	Descrizione <i>Description</i>			Dim.	Taglio <i>Cutting</i>	
Telaio <i>Frame</i>						
PR2915	Profilo telaio	<i>Profile frame</i>	1	(LS-92)/2	45°	90°
PR2915	Profilo telaio	<i>Profile frame</i>	1	(LS-92)/2	90°	45°
PR2915	Profilo telaio	<i>Profile frame</i>	1	HS	45°	45°
PR2965	Profilo telaio	<i>Profile frame</i>	1	(LS-92)/2	90°	45°
PR2965	Profilo telaio	<i>Profile frame</i>	1	(LS-92)/2	45°	90°
PR2965	Profilo telaio	<i>Profile frame</i>	1	HS	45°	45°
Anta <i>Leaf</i>						
PR2943	Profilo anta	<i>Profile leaf</i>	1	(LS-122)/2	45°	90°
PR2943	Profilo anta	<i>Profile leaf</i>	1	(LS-122)/2	90°	45°
PR2943	Profilo anta	<i>Profile leaf</i>	1	HS-30	45°	45°
PR2962	Profilo anta	<i>Profile leaf</i>	1	(LS-122)/2	90°	45°
PR2962	Profilo anta	<i>Profile leaf</i>	1	(LS-122)/2	45°	90°
PR2962	Profilo anta	<i>Profile leaf</i>	1	HS-30	45°	45°
PR2620	Profilo battiacqua	<i>Water drip profile</i>	1	LS-99	90°	90°
PR2670	Profilo battiacqua	<i>Water drip profile</i>	1	LS-5	90°	90°
Fermavetri <i>Glazing beads</i>						
PR2606	Profilo fermavetro	<i>Glazing beads profile</i>	2	LS-94	45°	45°
PR2606	Profilo fermavetro	<i>Glazing beads profile</i>	2	HS-94	45°	45°
Vetri <i>Glass</i>						
	Vetro camera	<i>Double Glazing</i>	1	LS-106 x HS-106		
ACCESSORI <i>HARDWARE</i>						
Codice <i>Code</i>	Descrizione <i>Description</i>				Dim.	
AC2608	Clips fissaggio fermavetri	<i>Clips to secure glazing beads</i>			var.	
AC2617N	Guarnizione d'angolo	<i>Vulcanised corner gasket</i>			2	
AC2618	Scarico acqua	<i>Water drip</i>			var.	
AC2533V	Coppia snodi bilico	<i>Pivot bearing</i>			1	
AC2625 D/S	Kit cremonese apertura interna	<i>Inwards opening cremone bolt set</i>			1	
AC2683 D/S	Kit cremonese apertura esterna	<i>Outwards opening cremone bolt set</i>			1	
AC2626R	Kit per terza chiusura	<i>Three-point lock system kit</i>			var.	
AC2686	Braccetto limitatore apertura	<i>Casement opening stays</i>			1	
ACV 77..	Maniglie "Vitruvio"	<i>Handle " Vitruvio"</i>			2	
AC2803I*	Kit squadrette per PR2915	<i>Corner brackets kit for PR2915</i>			2	
AC2843I*	Kit squadrette per PR2943	<i>Corner brackets kit for PR2943</i>			2	
AC2862I*	Kit squadrette per PR2962	<i>Corner brackets kit for PR2962</i>			2	
AC2865I*	Kit squadrette per PR2965	<i>Corner brackets kit for PR2965</i>			2	
GUARNIZIONI <i>WEATHER STRIP</i>						
GE2645TT	Guarnizione di battuta	<i>Internal weather strip</i>	1		3xLS+3xHS	
GE2603	Guarnizione giunto aperto	<i>Weather strip for open joint</i>	1		LS-110+HS	
GU2036	Piattina adesiva fondo giunto	<i>Adhesive shim for joint</i>	1		2xLS+2xHS	
GU2865	Spazzolino superiore apertura esterna	<i>Upper brush seal outwards opening</i>	1		(LS-X)-67	
GP0095	Guarnizione interna vetro	<i>Internal weather strip</i>	1		2xLS+2xHS	

* solo con profili ottone | *only with brass profiles*

N.B.: le dimensioni delle guarnizioni sono indicative e devono essere aumentate del 10% per adattamenti e ritiri del materiale nel tempo

Attention: the gasket dimensions are indicative and have to be increased by 10% owing to adaptation and contractions of the material over time

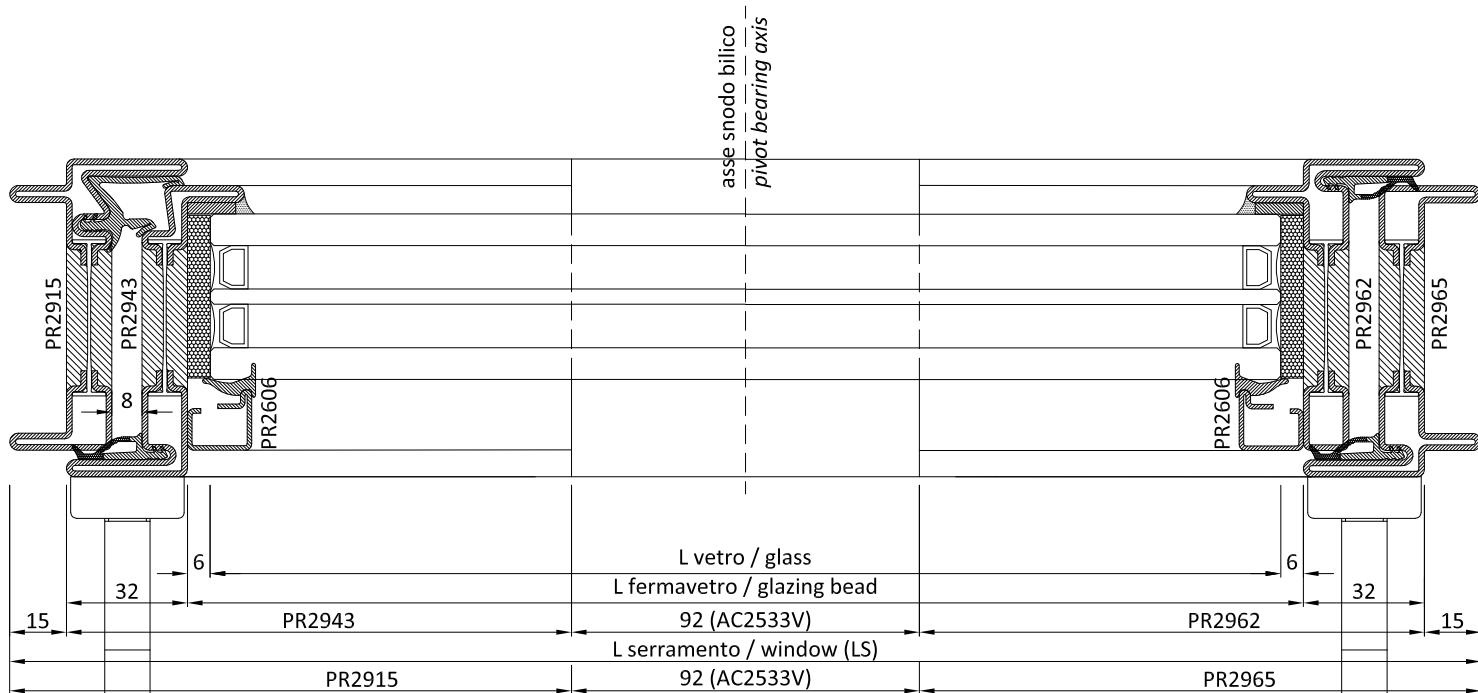
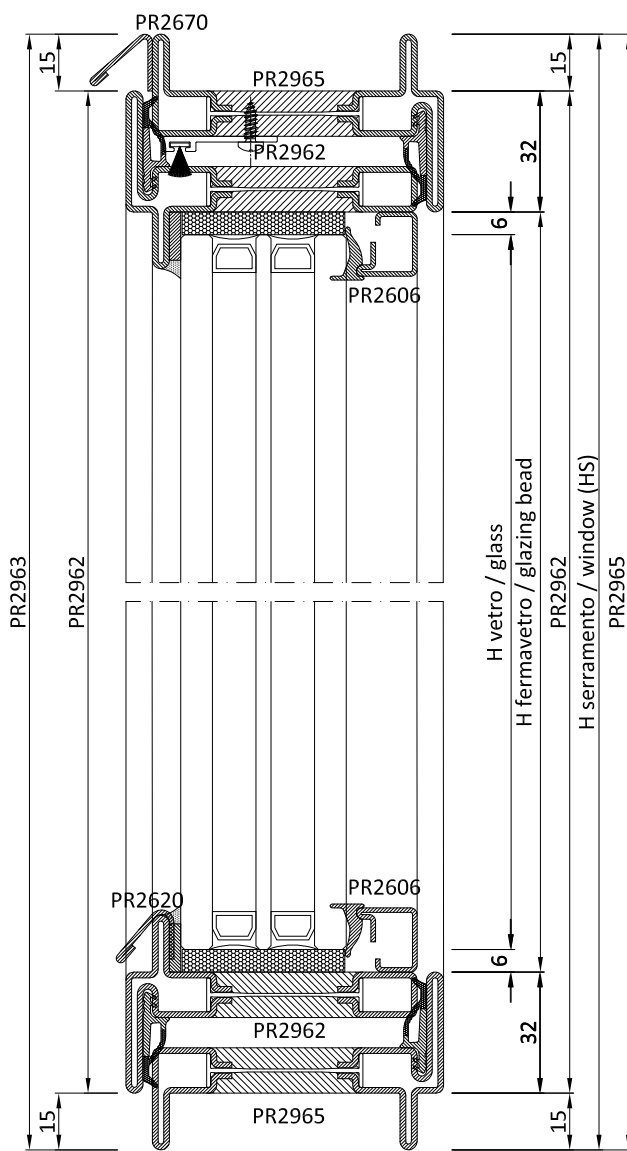
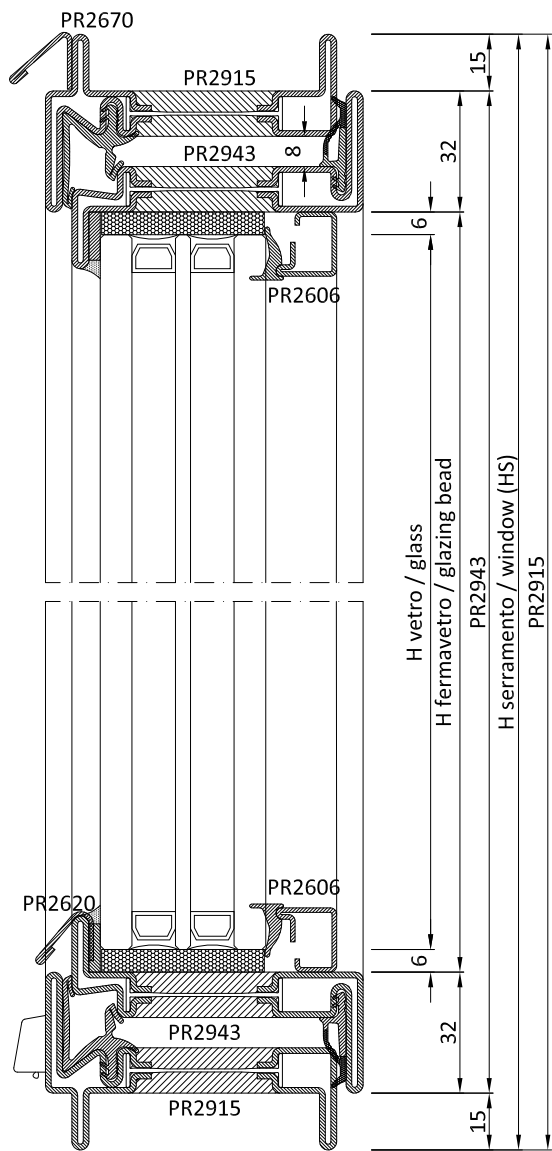

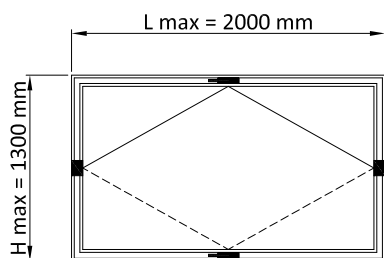

PROFILI <i>PROFILES</i>						
Codice <i>Code</i>	Descrizione <i>Description</i>			Dim.	Taglio <i>Cutting</i>	
Telaio <i>Frame</i>						
PR2915	Profilo telaio	<i>Profile frame</i>	1	LS	90°	90°
PR2915	Profilo telaio	<i>Profile frame</i>	1	(HS-92)/2	90°	45°
PR2915	Profilo telaio	<i>Profile frame</i>	1	(HS-92)/2	45°	90°
PR2965	Profilo telaio	<i>Profile frame</i>	1	LS	90°	90°
PR2965	Profilo telaio	<i>Profile frame</i>	1	(HS-92)/2	45°	90°
PR2965	Profilo telaio	<i>Profile frame</i>	1	(HS-92)/2	90°	45°
Anta <i>Leaf</i>						
PR2943	Profilo anta	<i>Profile leaf</i>	1	LS-30	45°	45°
PR2943	Profilo anta	<i>Profile leaf</i>	1	(HS-122)/2	90°	45°
PR2943	Profilo anta	<i>Profile leaf</i>	1	(HS-122)/2	45°	90°
PR2962	Profilo anta	<i>Profile leaf</i>	1	LS-30	45°	45°
PR2962	Profilo anta	<i>Profile leaf</i>	1	(HS-122)/2	45°	90°
PR2962	Profilo anta	<i>Profile leaf</i>	1	(HS-122)/2	90°	45°
Fermavetri <i>Glazing beads</i>						
PR2606	Profilo fermavetro	<i>Glazing beads profile</i>	2	LS-94	45°	45°
PR2606	Profilo fermavetro	<i>Glazing beads profile</i>	2	HS-94	45°	45°
Vetri <i>Glass</i>						
	Vetro camera	<i>Double Glazing</i>	1	LS-106 x HS-106		
ACCESSORI <i>HARDWARE</i>						
Codice <i>Code</i>	Descrizione <i>Description</i>				Dim.	
AC2608	Clips fissaggio fermavetri	<i>Clips to secure glazing beads</i>			var.	
AC2617N	Guarnizione d'angolo	<i>Vulcanised corner gasket</i>			2	
AC2533H	Coppia snodi bilico	<i>Pivot bearing</i>			1	
AC2625 D/S	Kit cremonese apertura interna	<i>Inwards opening cremona bolt set</i>			1	
AC2683 D/S	Kit cremonese apertura esterna	<i>Outwards opening cremona bolt set</i>			1	
AC2626R	Kit per terza chiusura	<i>Three-point lock system kit</i>			var.	
AC2686	Braccetto limitatore apertura	<i>Casement opening stays</i>			1	
ACV 77..	Maniglie "Vitruvio"	<i>Handle " Vitruvio"</i>			2	
AC2803I*	Kit squadrette per PR2915	<i>Corner brackets kit for PR2915</i>			2	
AC2843I*	Kit squadrette per PR2943	<i>Corner brackets kit for PR2943</i>			2	
AC2862I*	Kit squadrette per PR2962	<i>Corner brackets kit for PR2962</i>			2	
AC2865I*	Kit squadrette per PR2965	<i>Corner brackets kit for PR2965</i>			2	
GE2645TT	Guarnizione di battuta	<i>Internal weather strip</i>	1		3xLS+3xHS	
GE2603	Guarnizione giunto aperto	<i>Weather strip for open joint</i>	1		LS+HS	
GU2036	Piattina adesiva fondo giunto	<i>Adhesive shim for joint</i>	1		2xLS+2xHS	
GP0095	Guarnizione interna vetro	<i>Internal weather strip</i>	1		2xLS+2xHS	

* solo con profili ottone | *only with brass profiles*

N.B.: le dimensioni delle guarnizioni sono indicative e devono essere aumentate del 10% per adattamenti e ritiri del materiale nel tempo
Attention: the gasket dimensions are indicative and have to be increased by 10% owing to adaptation and contractions of the material over time

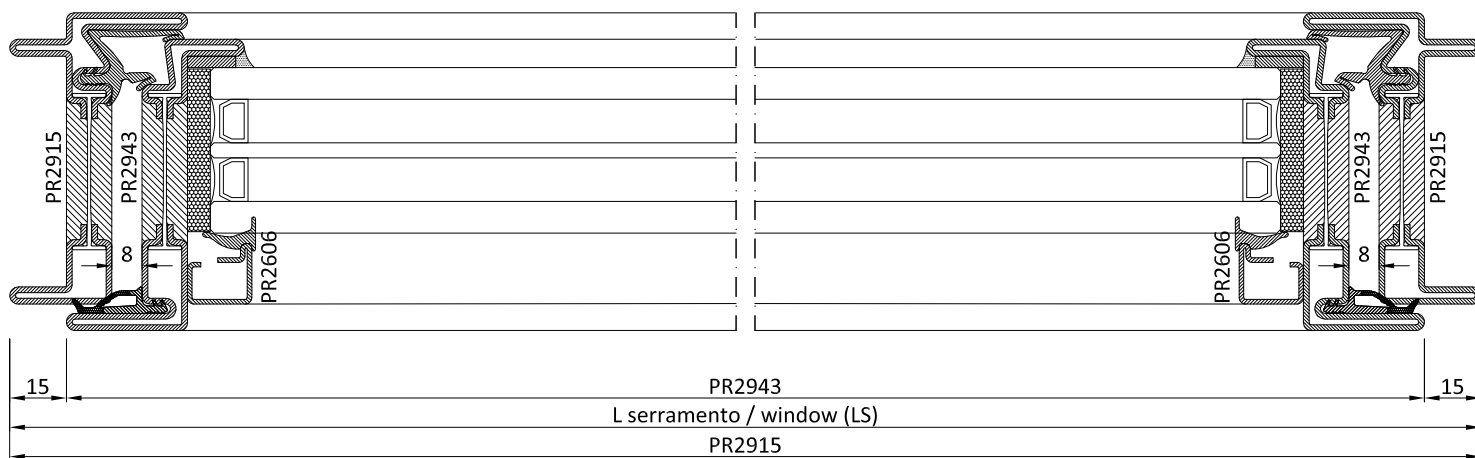
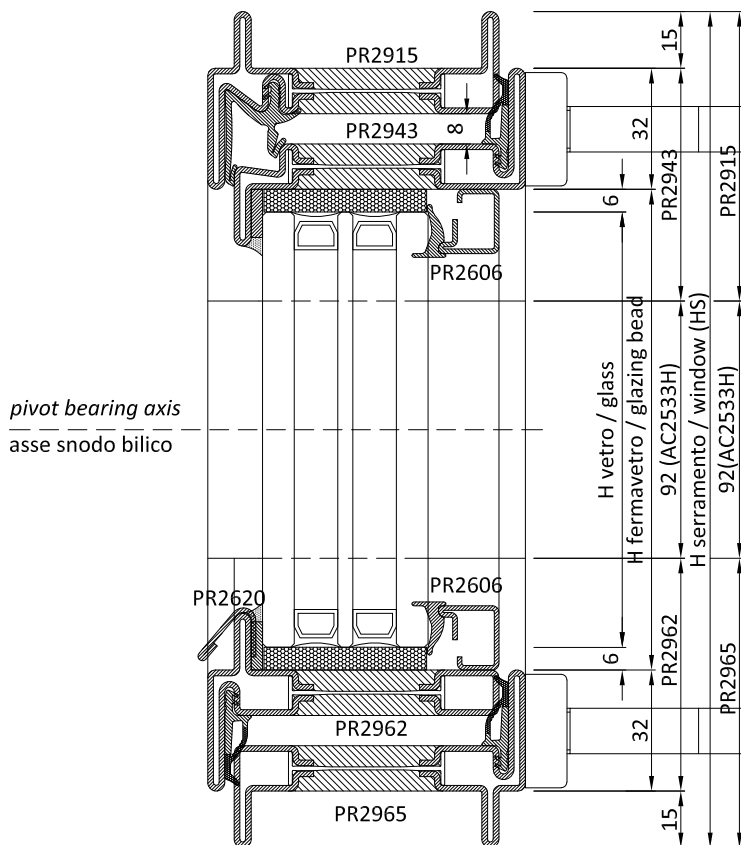

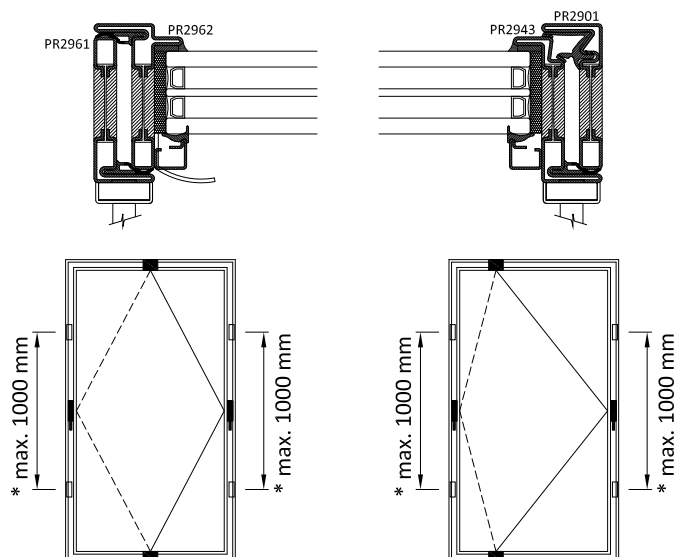

Art.	Code	Descrizione Description	Pag.
AC2625	D/S	Kit cremonese chiusura apertura interna <i>Cremona bolt set inwards opening</i>	4.3.7 4.5.2-3
AC2683	D/S	Kit cremonese chiusura apertura esterna <i>Cremona bolt set outwards opening</i>	4.3.8-9 4.5.4-5
AC2533	SV	Snodo bilico <i>Pivot bearing</i>	4.3.12 15 4.4.8 9 - 5.1.5
AC2626	R	Chiusura supplementare <i>Additional lock</i>	4.3.10 11 4.5.6

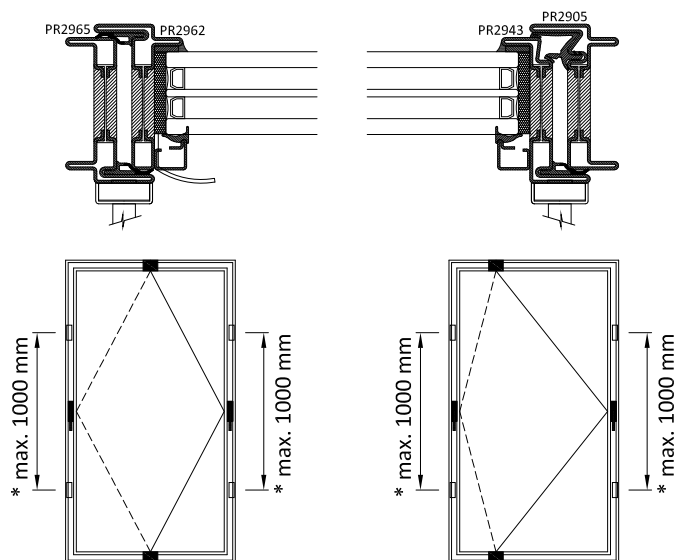

Art.	Code	Descrizione Description	Pag.
AC2625	D/S	Kit cremonese chiusura apertura interna <i>Cremona bolt set inwards opening</i>	4.3.7 4.5.2-3
AC2683	D/S	Kit cremonese chiusura apertura esterna <i>Cremona bolt set outwards opening</i>	4.3.8-9 4.5.4-5
AC2533	V	Snodo bilico <i>Pivot bearing</i>	4.3.12 15 4.4.6 7 - 5.1.5
AC2626	R	Chiusura supplementare <i>Additional lock</i>	4.3.10 11 4.5.6

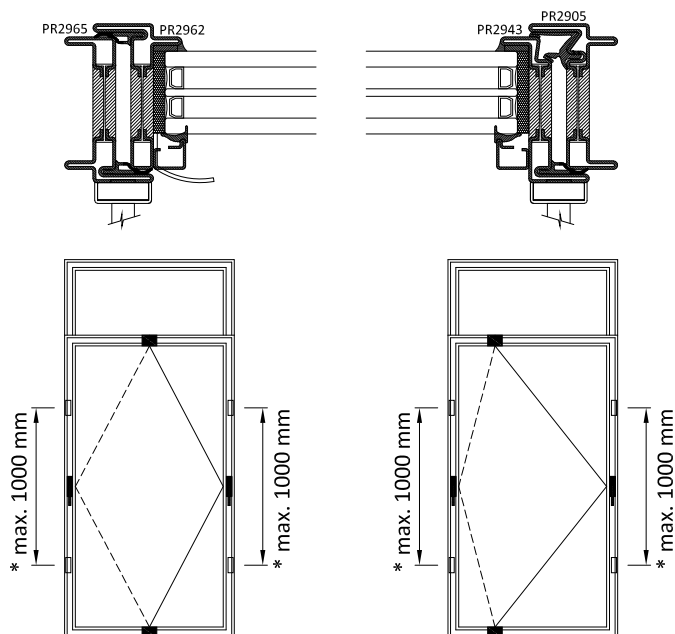

Art.	Code	Descrizione Description	Pag.
AC2625	D/S	Kit cremonese chiusura apertura interna <i>Cremona bolt set inwards opening</i>	4.3.7 4.5.2-3
AC2683	D/S	Kit cremonese chiusura apertura esterna <i>Cremona bolt set outwards opening</i>	4.3.8-9 4.5.4-5
AC2537V		Snodo bilico <i>Pivot bearing</i>	4.3.12 15 4.4.10 11 - 5.1.5
AC2626	R	Chiusura supplementare <i>Additional lock</i>	4.3.10 11 4.5.6

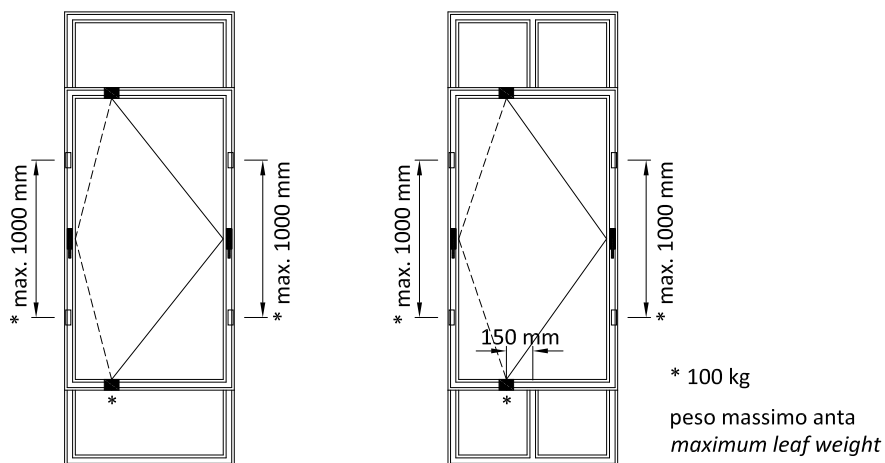

Art.	Code	Descrizione Description	Pag.
AC2625	D/S	Kit cremonese chiusura apertura interna <i>Cremona bolt set inwards opening</i>	4.3.7 4.5.2-3
AC2683	D/S	Kit cremonese chiusura apertura esterna <i>Cremona bolt set outwards opening</i>	4.3.8-9 4.5.4-5
AC2538V		Snodo bilico <i>Pivot bearing</i>	4.3.12 15 4.4.12 13 - 5.1.5
AC2626	R	Chiusura supplementare <i>Additional lock</i>	4.3.10 11 4.5.6

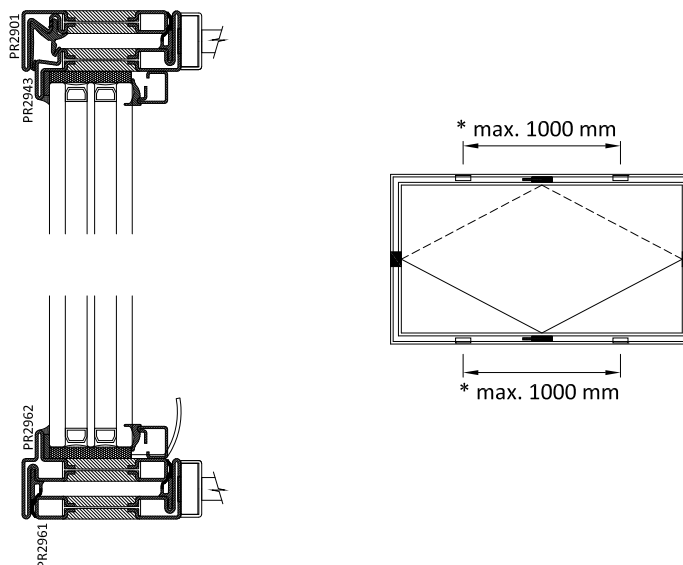

Art.	Code	Descrizione Description	Pag.
AC2625	D/S	Kit cremonese chiusura apertura interna <i>Cremone bolt set inwards opening</i>	4.3.7 4.5.2-3
AC2683	D/S	Kit cremonese chiusura apertura esterna <i>Cremone bolt set outwards opening</i>	4.3.8-9 4.5.4-5
AC2533	SH	Snodo bilico <i>Pivot bearing</i>	4.3.12 15 4.4.8 9 - 5.1.5
AC2626	R	Chiusura supplementare <i>Additional lock</i>	4.3.10 11 4.5.6

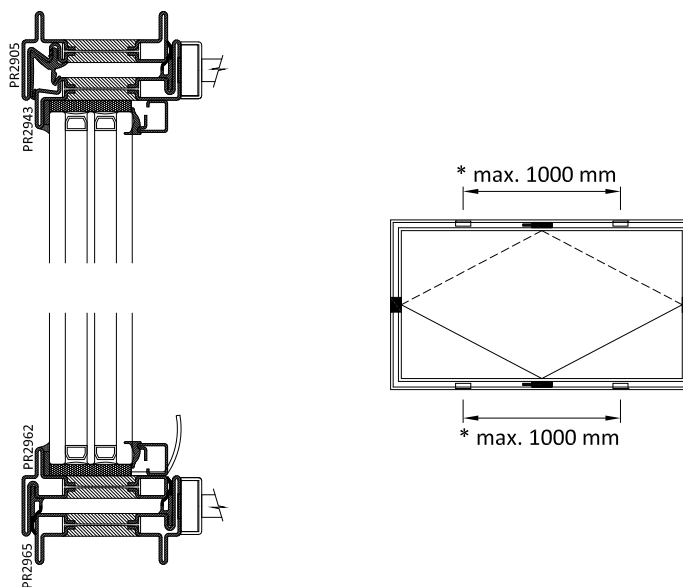

Art.	Code	Descrizione Description	Pag.
AC2625	D/S	Kit cremonese chiusura apertura interna <i>Cremone bolt set inwards opening</i>	4.3.7 4.5.2-3
AC2683	D/S	Kit cremonese chiusura apertura esterna <i>Cremone bolt set outwards opening</i>	4.3.8-9 4.5.4-5
AC2533	H	Snodo bilico <i>Pivot bearing</i>	4.3.12 15 4.4.6 7 - 5.1.5
AC2626	R	Chiusura supplementare <i>Additional lock</i>	4.3.10 11 4.5.6

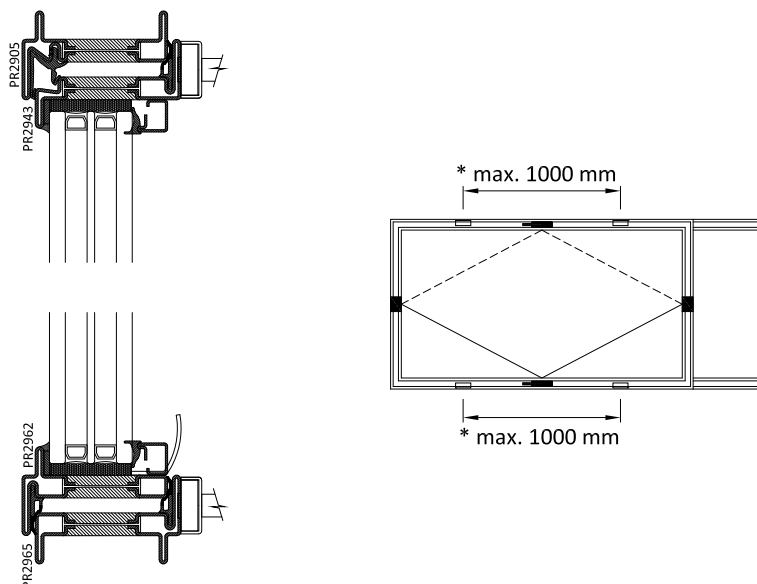

Art.	Code	Descrizione Description	Pag.
AC2625	D/S	Kit cremonese chiusura apertura interna <i>Cremonese bolt set inwards opening</i>	4.3.7 4.5.2-3
AC2683	D/S	Kit cremonese chiusura apertura esterna <i>Cremonese bolt set outwards opening</i>	4.3.8-9 4.5.4-5
AC2537	H	Snodo bilico <i>Pivot bearing</i>	4.3.12 15 4.4.10 11 - 5.1.5
AC2626	R	Chiusura supplementare <i>Additional lock</i>	4.3.10 11 4.5.6

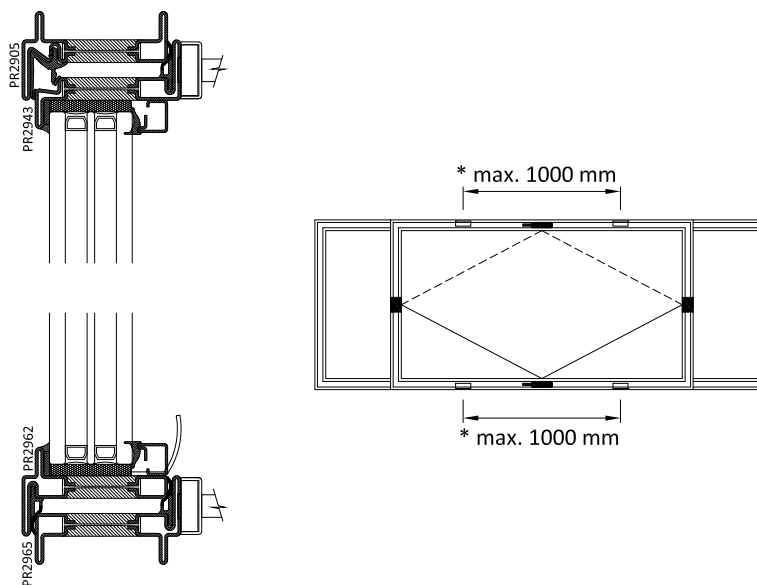

Art.	Code	Descrizione Description	Pag.
AC2625	D/S	Kit cremonese chiusura apertura interna <i>Cremonese bolt set inwards opening</i>	4.3.7 4.5.2-3
AC2683	D/S	Kit cremonese chiusura apertura esterna <i>Cremonese bolt set outwards opening</i>	4.3.8-9 4.5.4-5
AC2538	H	Snodo bilico <i>Pivot bearing</i>	4.3.12 15 4.4.12 13 - 5.1.5
AC2626	R	Chiusura supplementare <i>Additional lock</i>	4.3.10 11 4.5.6

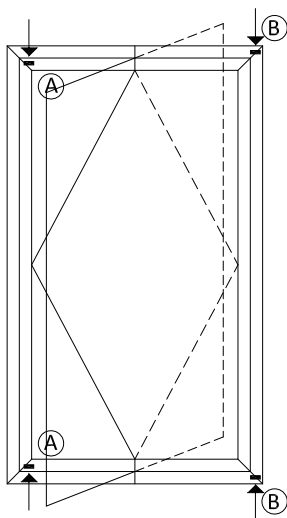
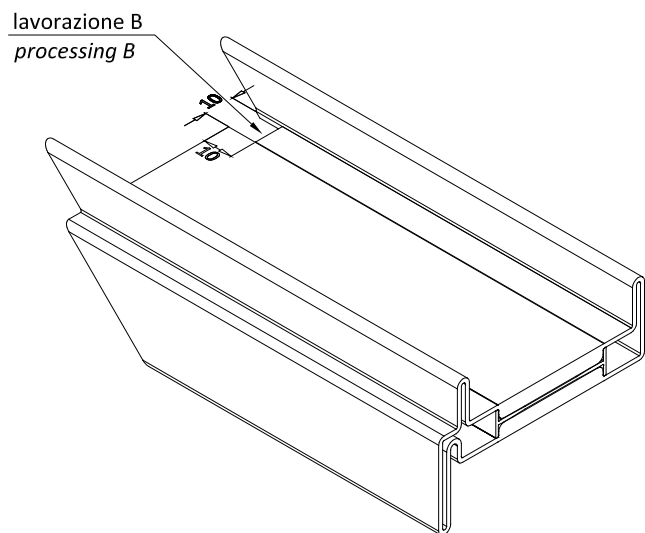
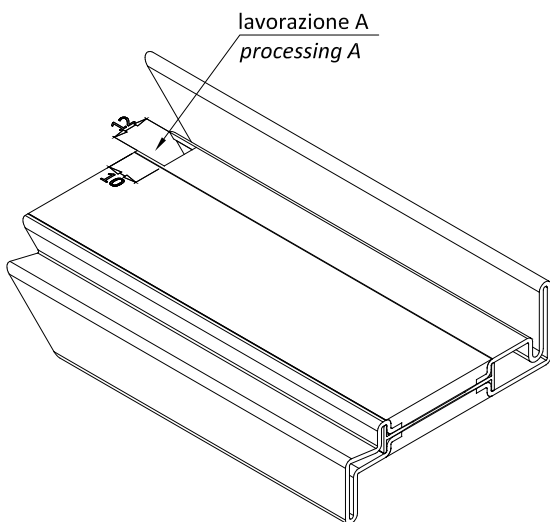
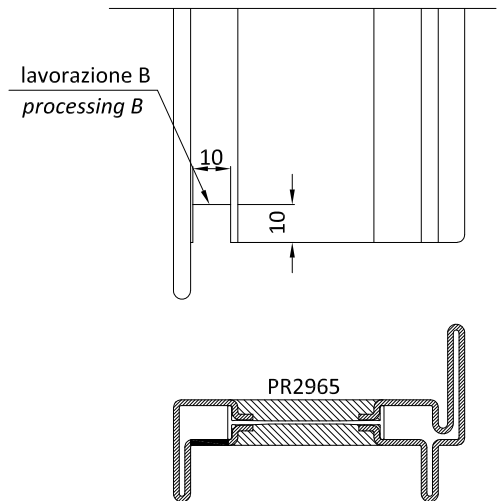
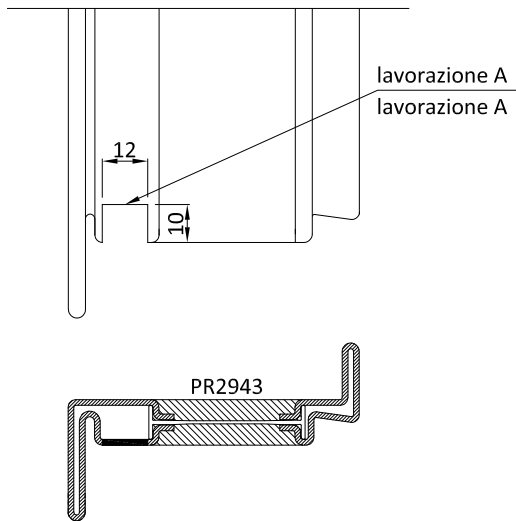

lavorazione per inserimento aste cremone
processing for inserting cremone bolt rod

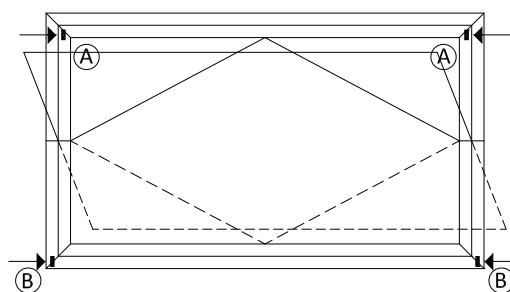

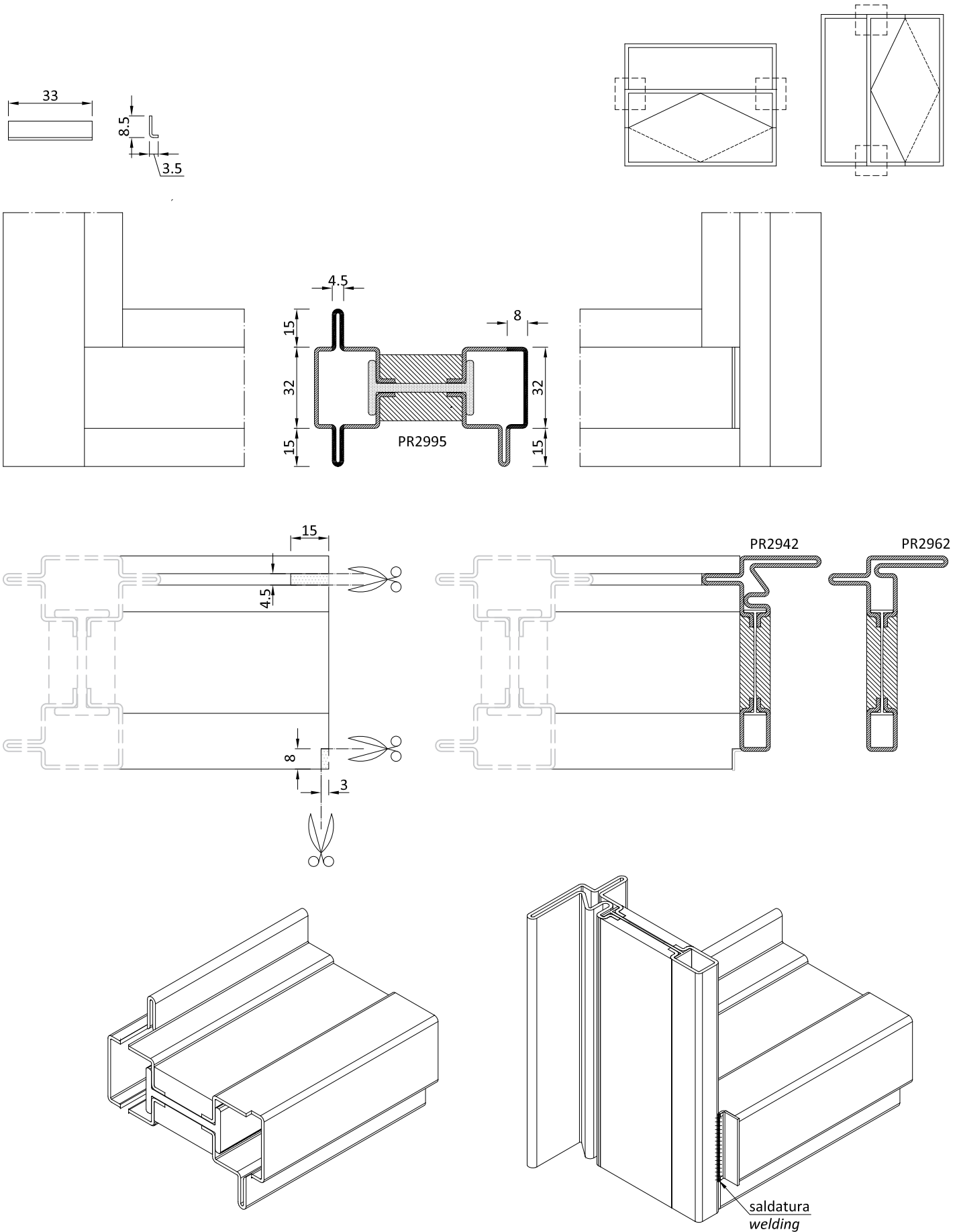

Nota: i fondini sono forniti di dimensioni maggiori da rifilare dopo la saldatura
 Note: the fitting are provided larger by trimming after welding

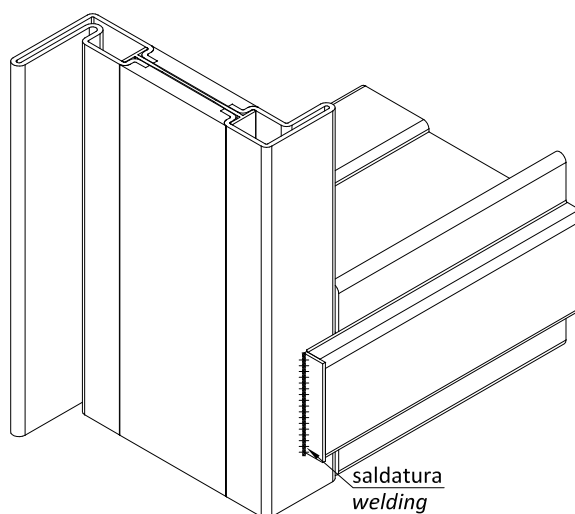
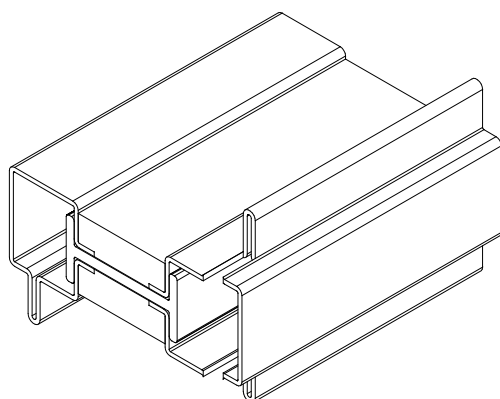
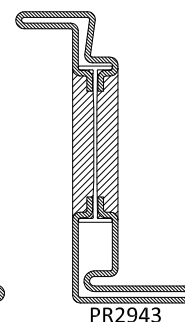
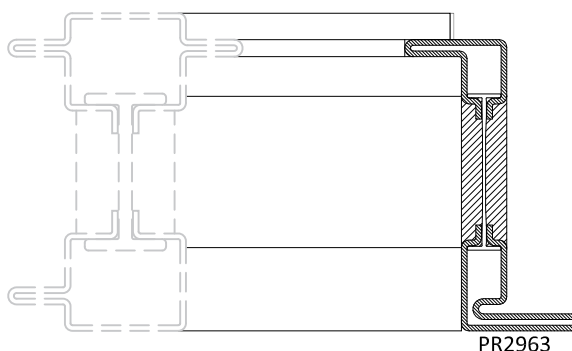
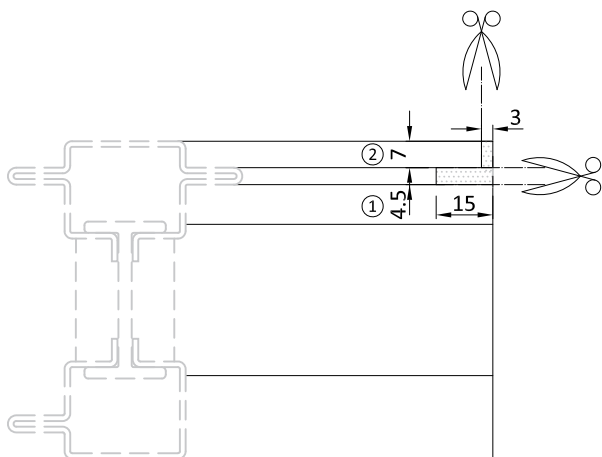
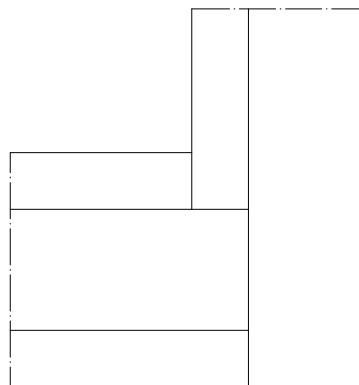
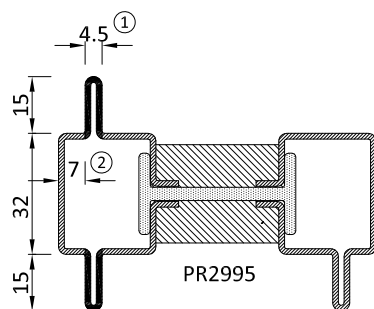
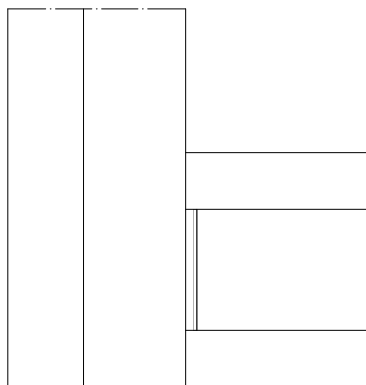
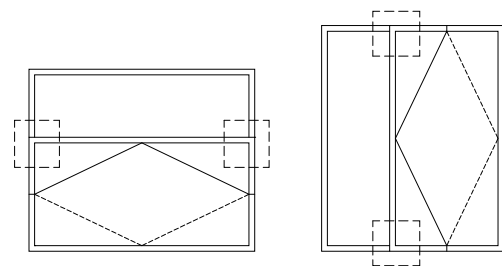
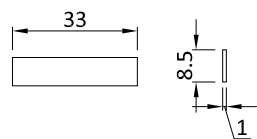

Nota: i fondini sono forniti di dimensioni maggiori da rifilare dopo la saldatura
Note: the fittings are provided larger by trimming after welding

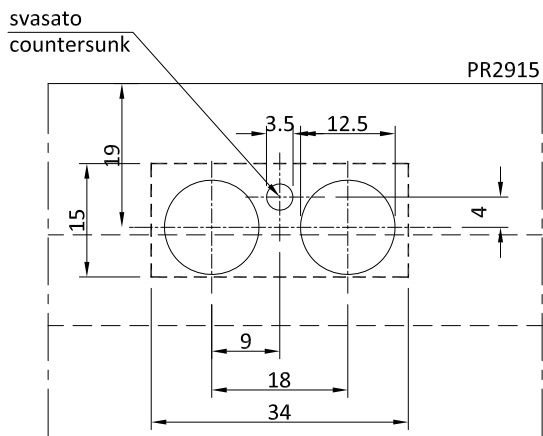

Particolare A

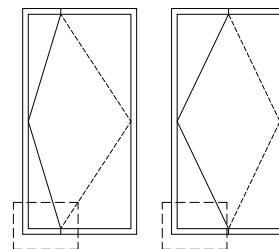

AC 2618
ACB 219
AC 2618NE

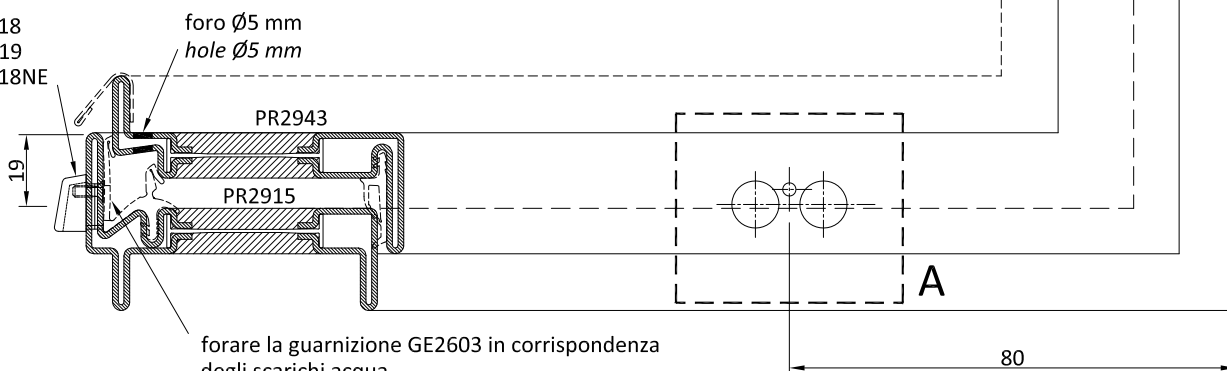

forare la guarnizione GE2603 in corrispondenza degli scarichi acqua
Pierce the gasket GE2603 in correspondence of the weep holes

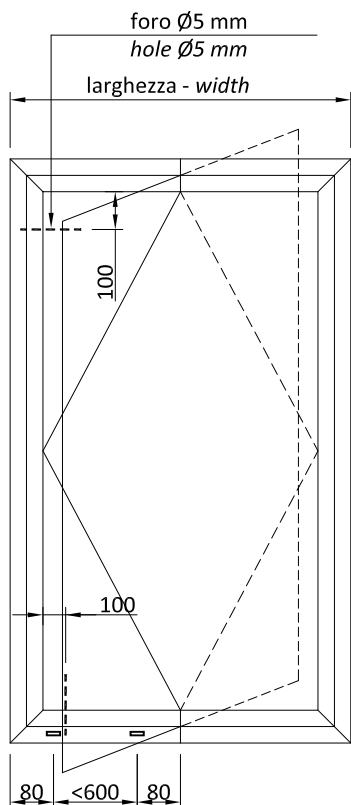

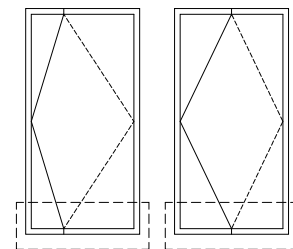
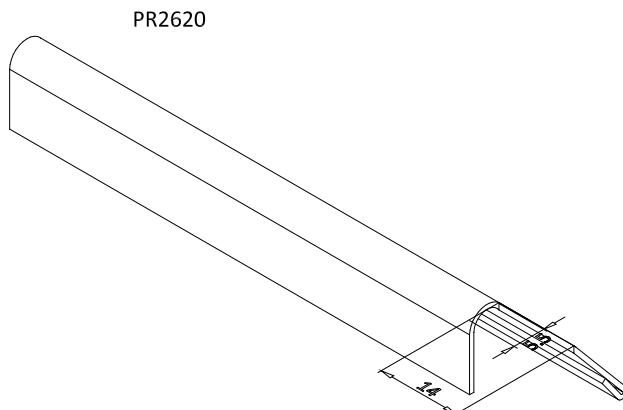

sigillare per tutta la lunghezza.
seal along the entire length

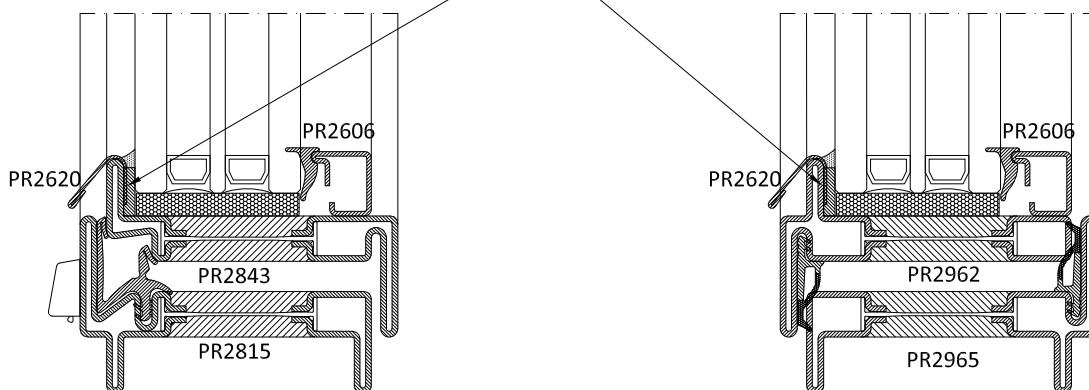

spacco ambo i lati
holes on both sides

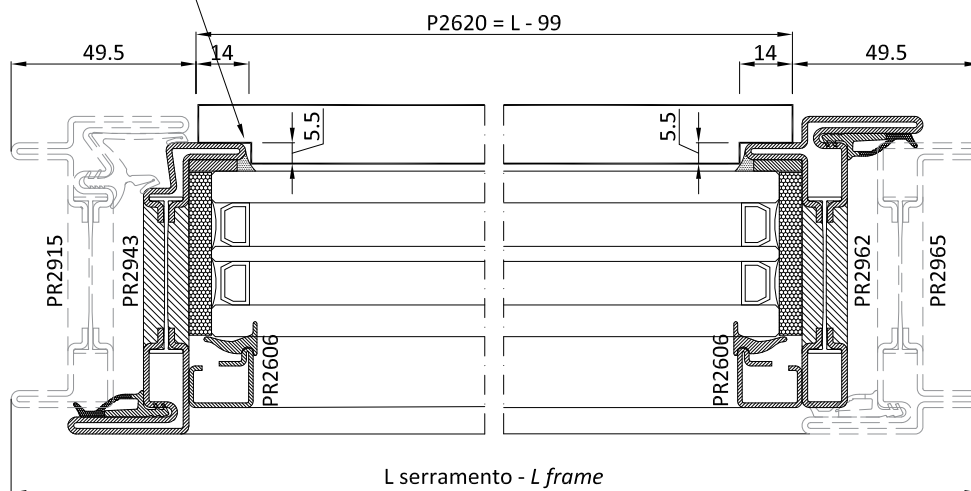

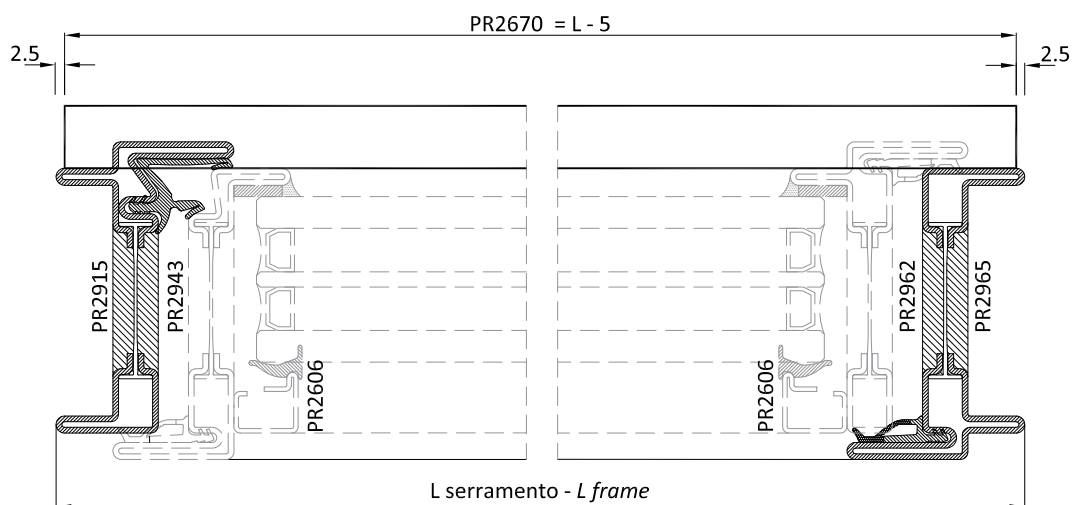
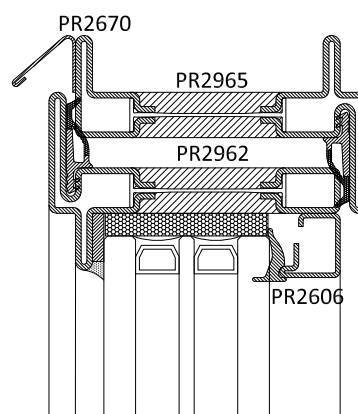
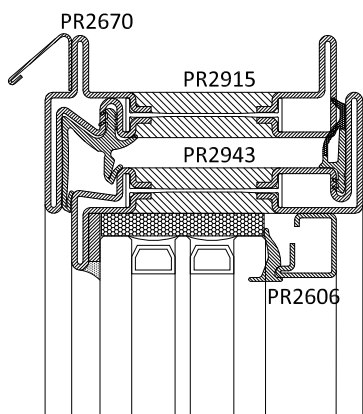
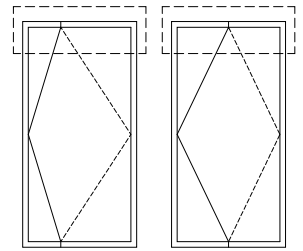
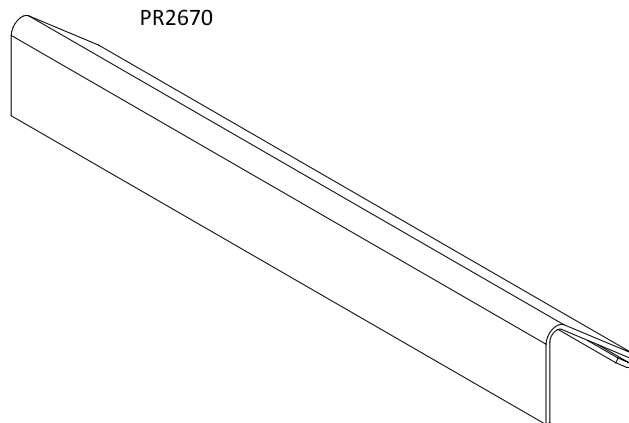

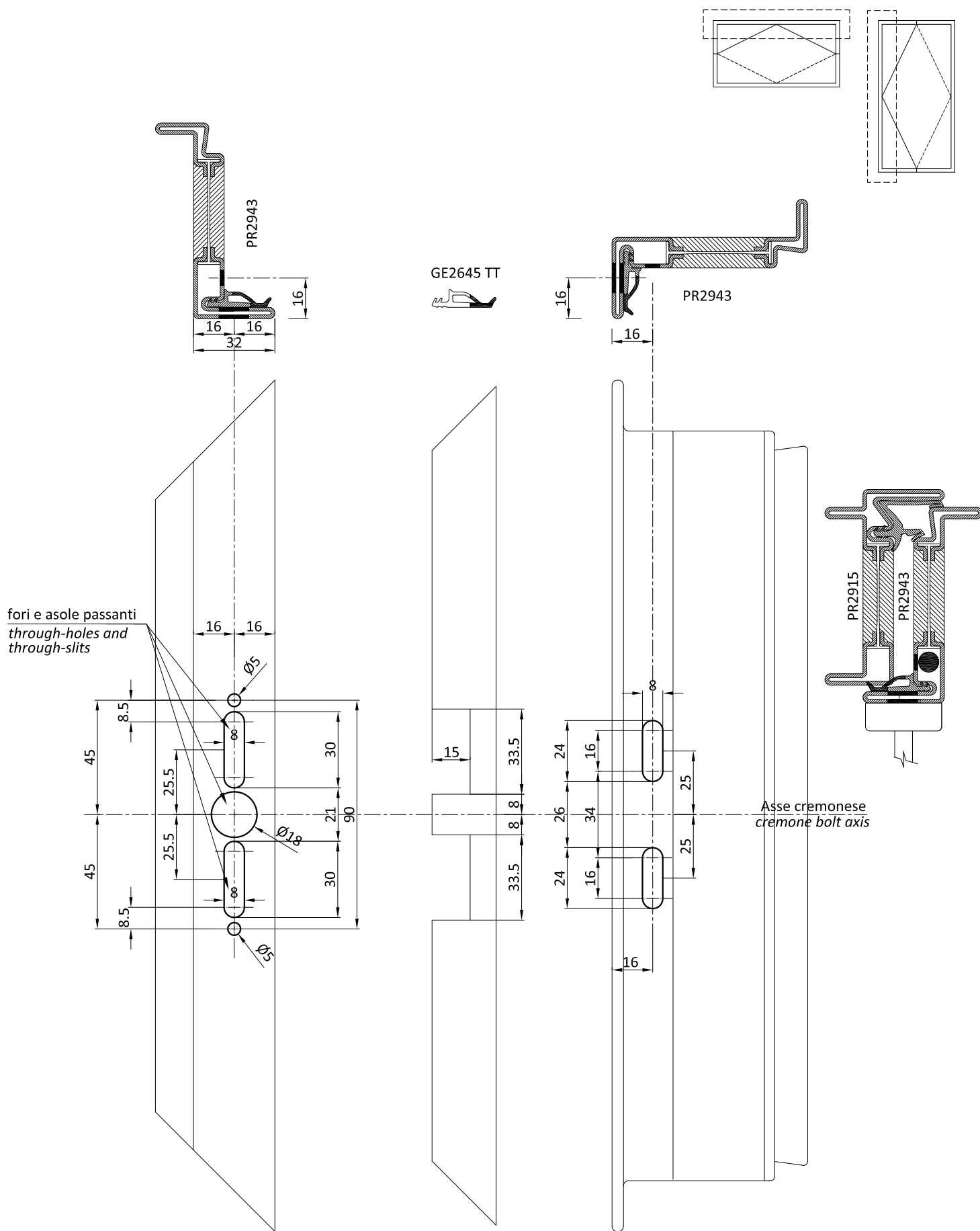

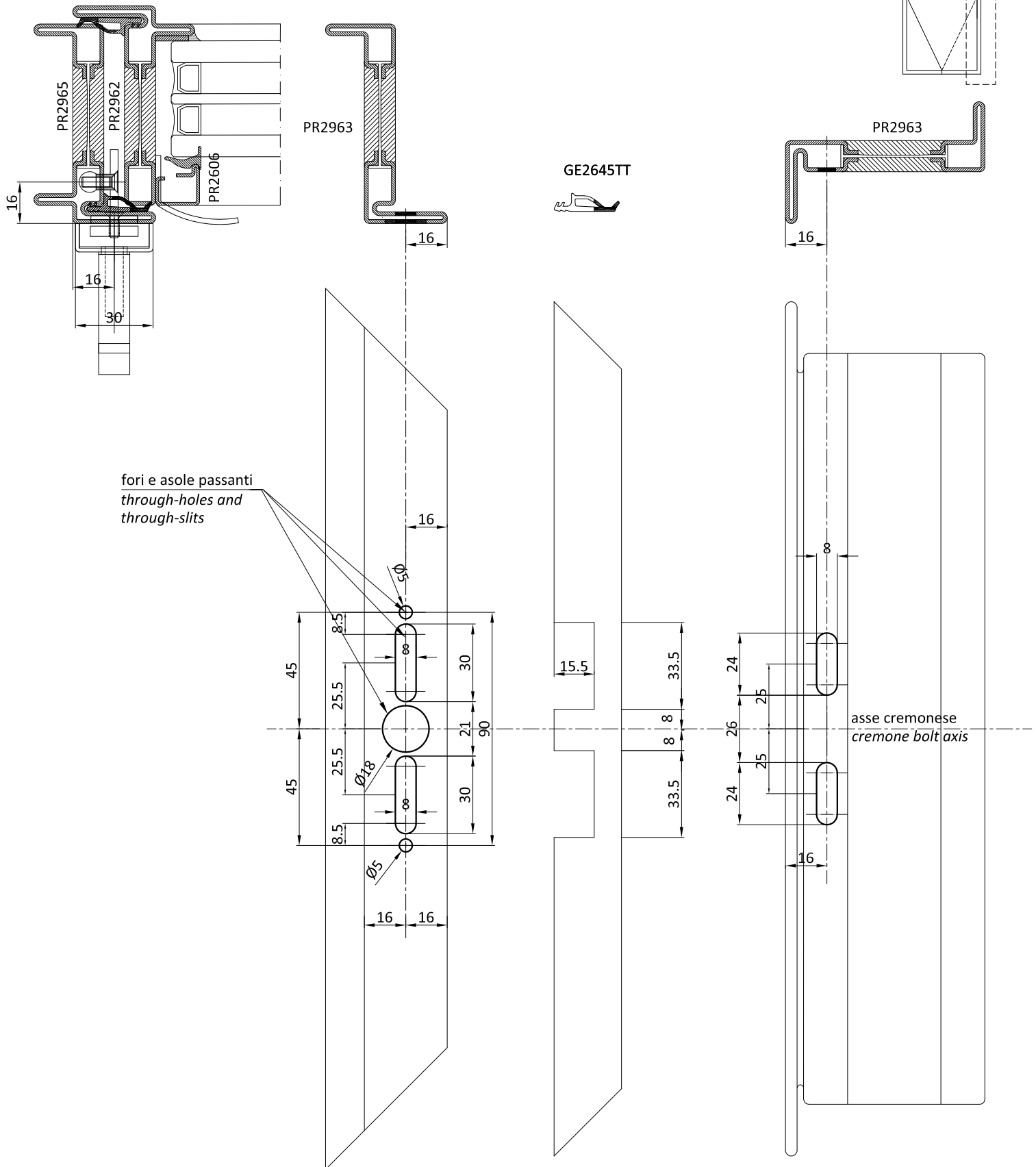

lavorazione applicazione incontro
Processing for strike plate installation

asse nottolino 3^a chiusura in posizione aperta
3rd plug axis in open leaf position

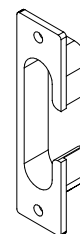
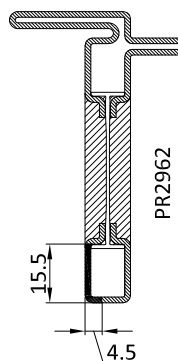
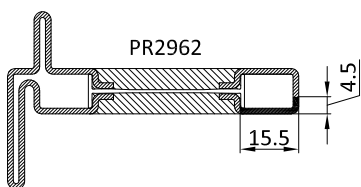
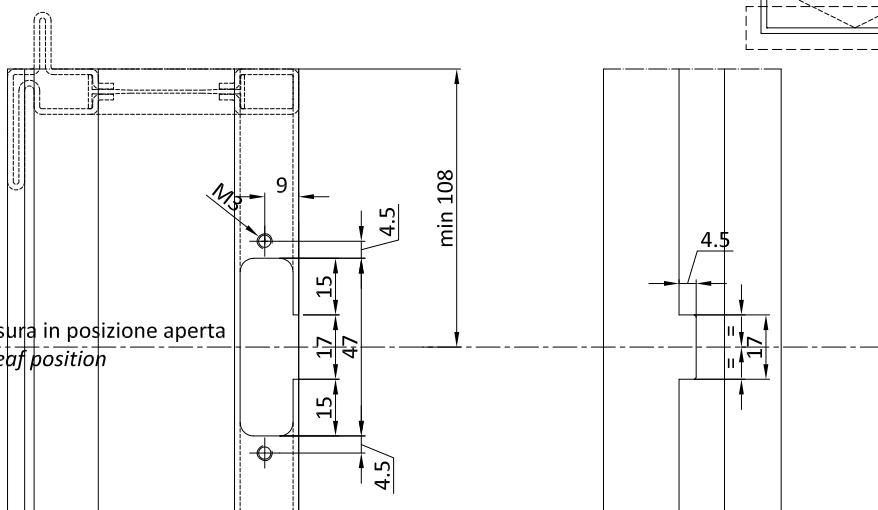

Incontro 3^a chiusura
3rd lock strike plate

lavorazione applicazione nottolino
Processing for plug installation

asse nottolino 3^a chiusura in posizione aperta
3rd plug axis in open leaf position

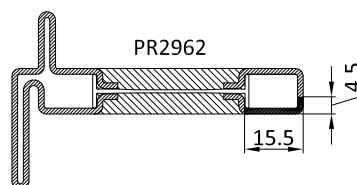
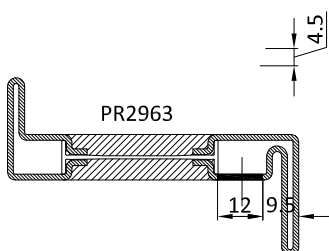
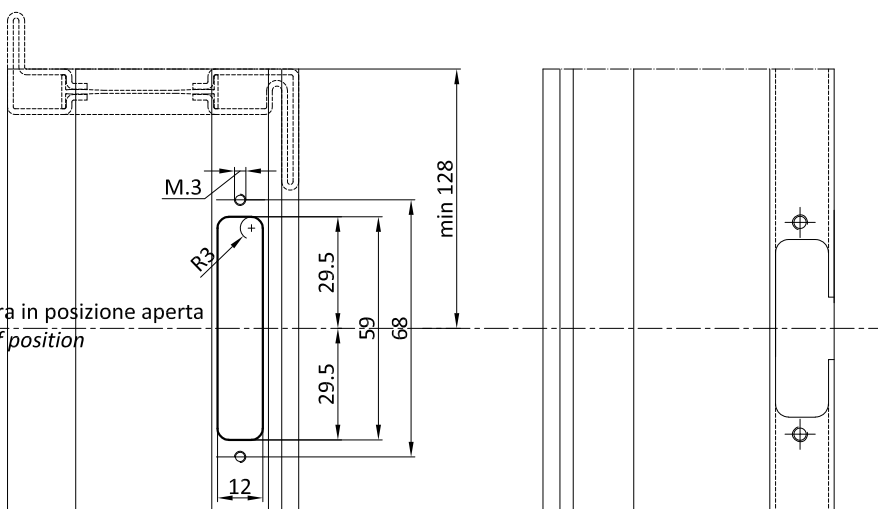

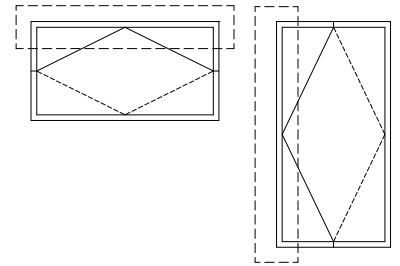

lavorazione applicazione incontro
Processing for the installation of the strike plate

asse nottolino 3^a chiusura in posizione aperta
3rd plug axis in open leaf position

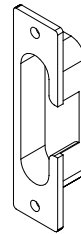
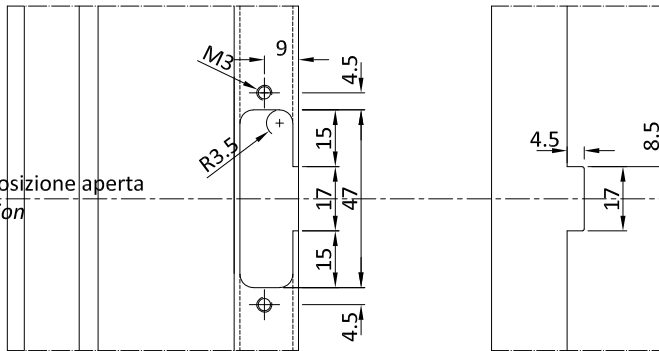

Incontro 3^a chiusura
3rd lock strike plate

N.B.: Distanza massima tra i punti di chiusura 1000 mm

N.B.: Distance between the closing points max. 1000 mm

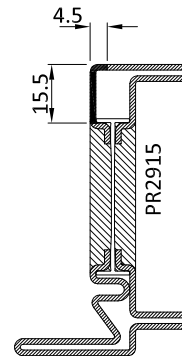
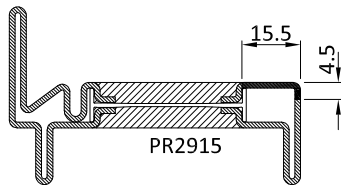

lavorazione applicazione nottolino
Processing for plug installation

asse nottolino 3^a chiusura in posizione aperta
3rd plug axis in open leaf position

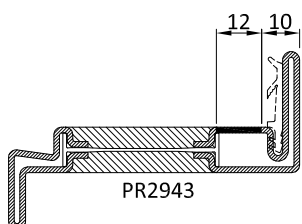
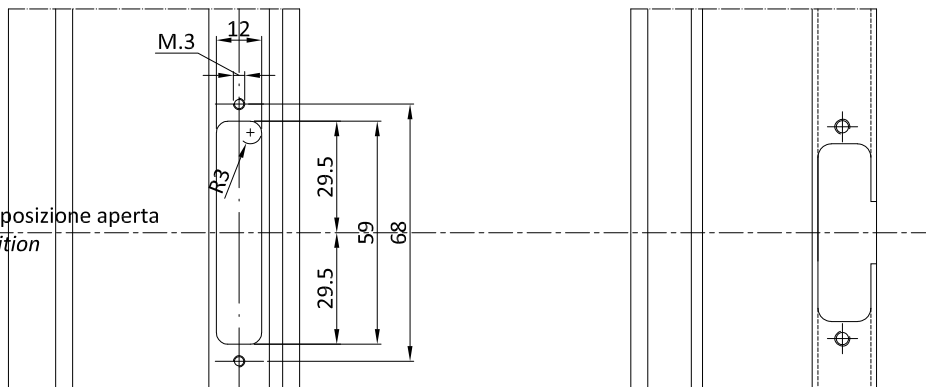

tagliare la guarnizione dove interseca la chiusura
cut the gasket in correspondence of closure

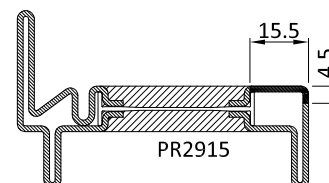

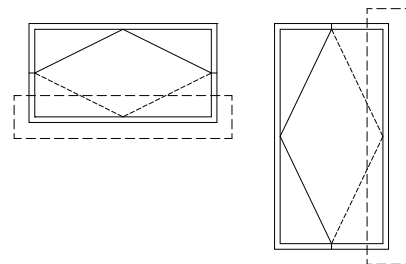

lavorazione applicazione incontro
Processing for the installation of the strike plate

asse nottolino 3^a chiusura in posizione aperta
3rd plug axis in open leaf position

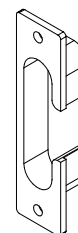
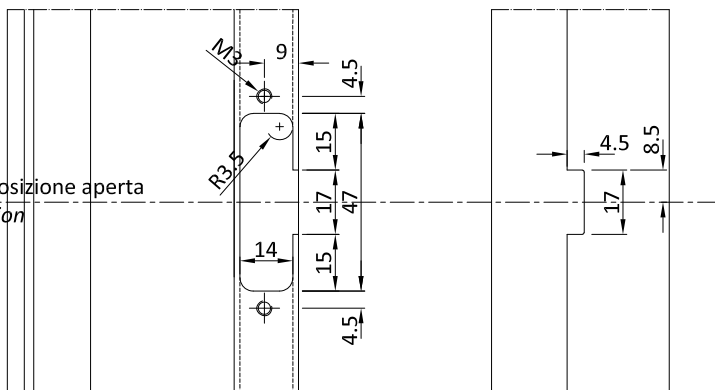

Incontro 3^a chiusura
3rd lock strike plate

N.B.: Distanza massima tra i punti di chiusura 1000 mm

N.B.: Distance between the closing points max. 1000 mm

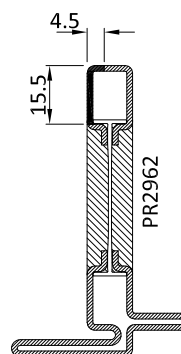
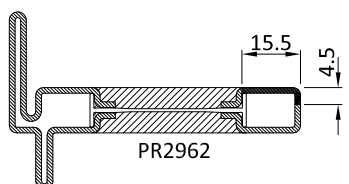

lavorazione applicazione nottolino
Processing for plug installation

asse nottolino 3^a chiusura in posizione aperta
3rd plug axis in open leaf position

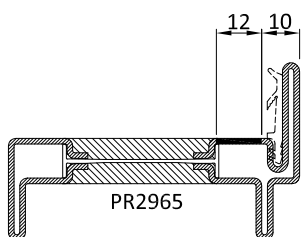
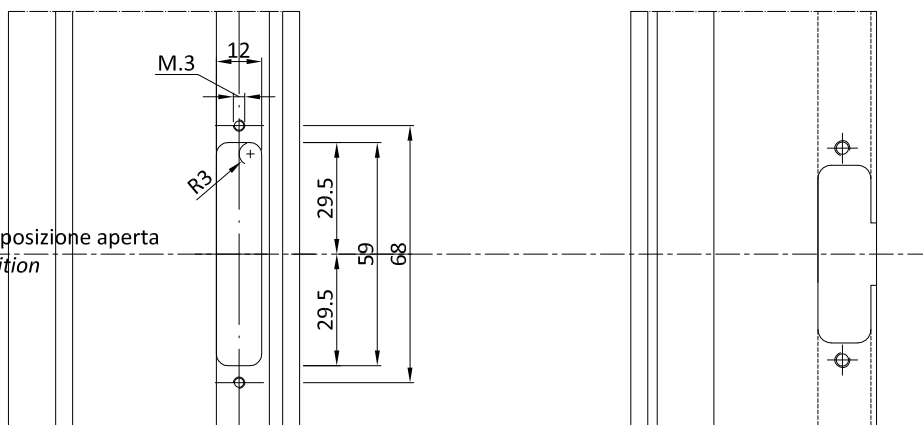

tagliare la guarnizione dove interseca la chiusura
cut the gasket in correspondence of closure

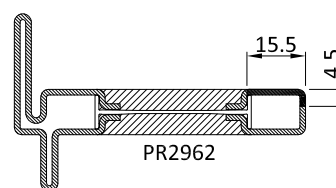

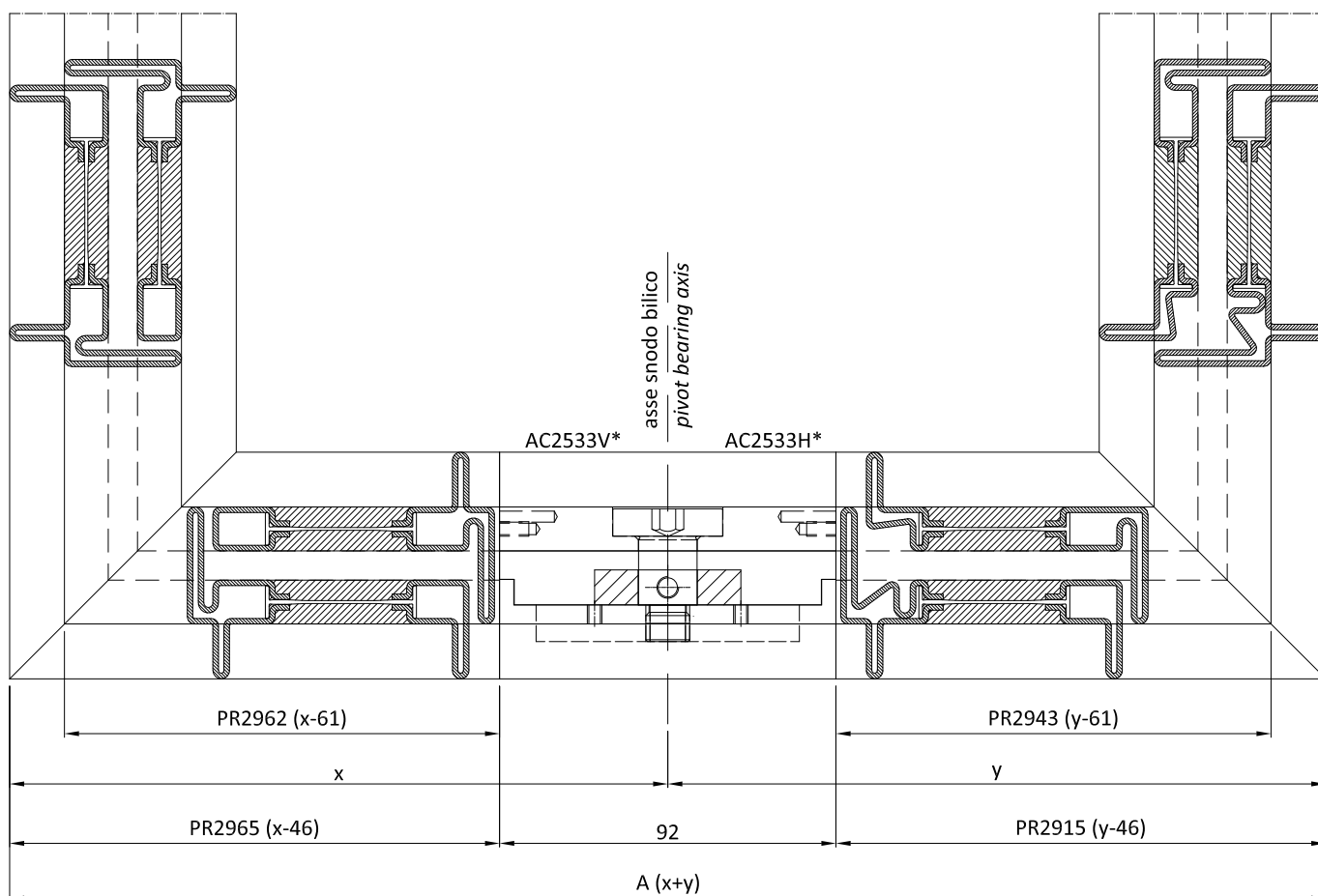
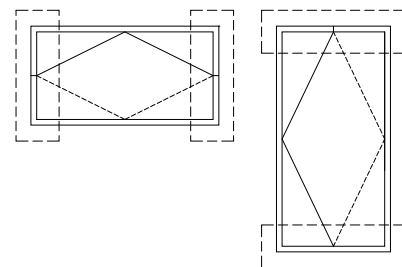

* Indicazioni valide anche per soluzione con partizioni fisse superiori e inferiori
(AC2533SV - AC2537V - AC2538V - AC2533SH - AC2537H - AC2538H)

* Instruction valid also for the solution with upper and bottom fixed frames
(AC2533SV - AC2537V - AC2538V - AC2533SH - AC2537H - AC2538H)

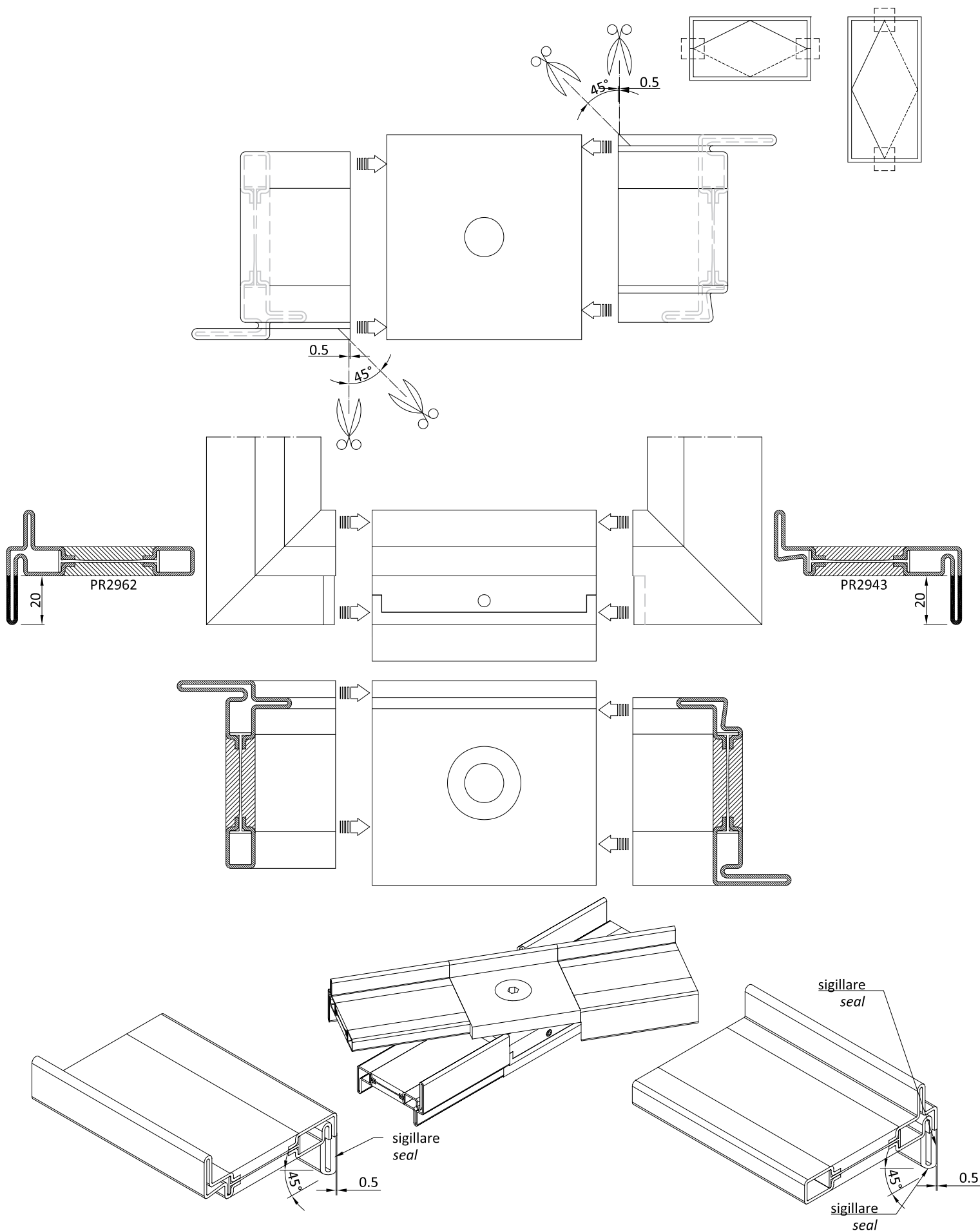

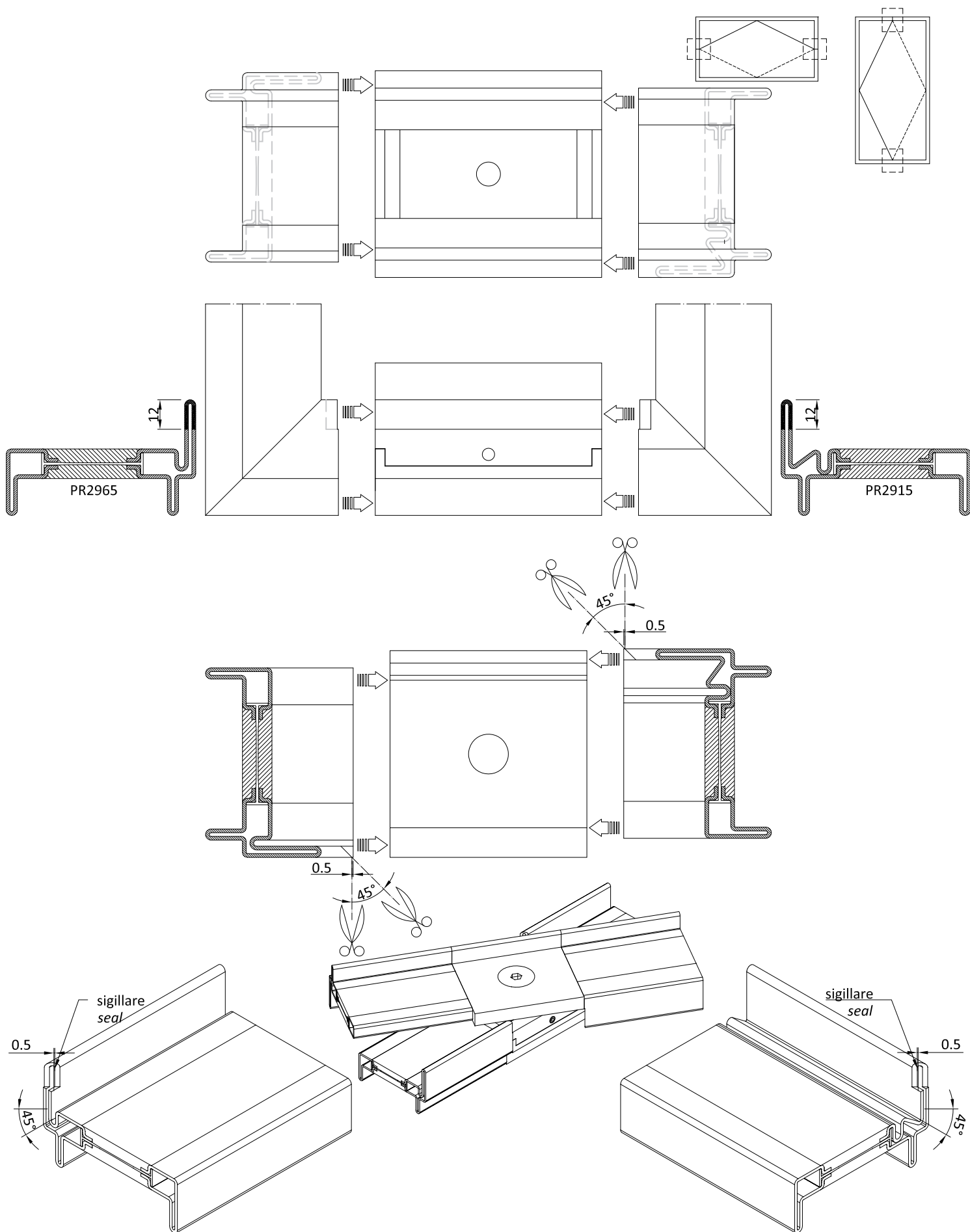

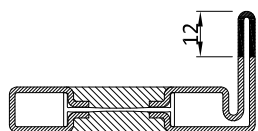
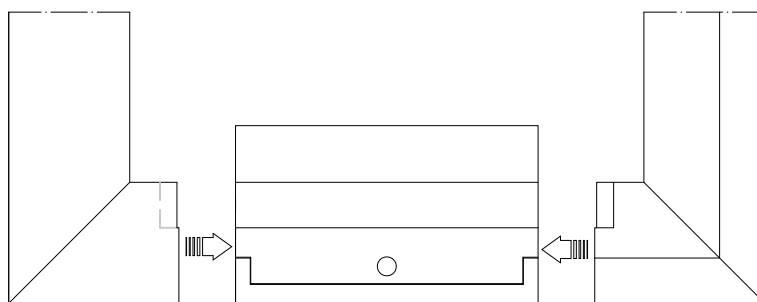
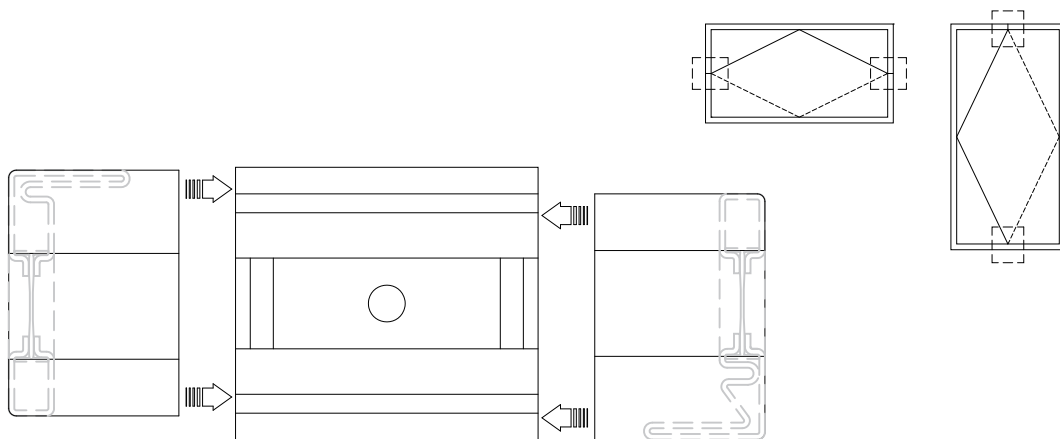

PR2861



PR2901

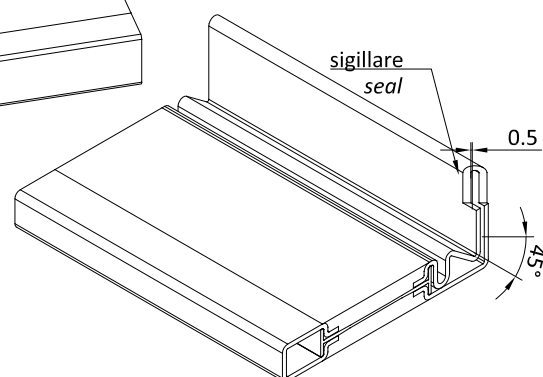
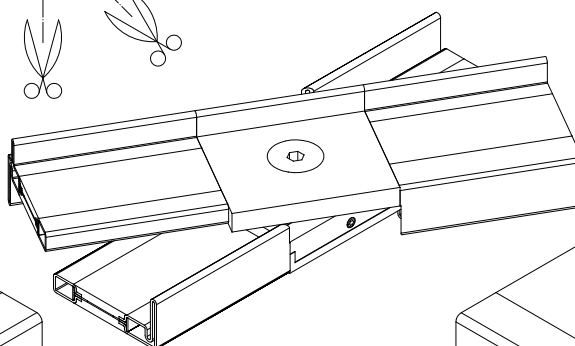
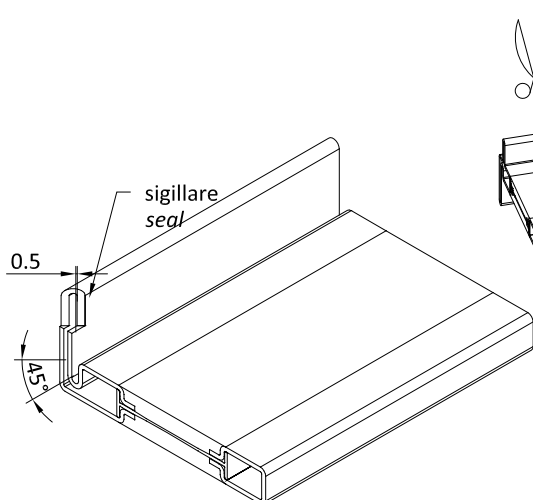
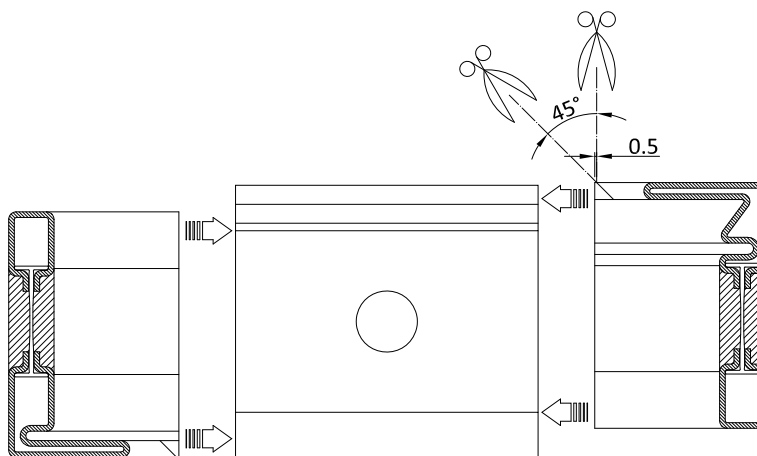

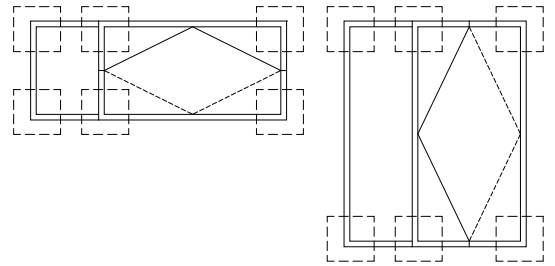
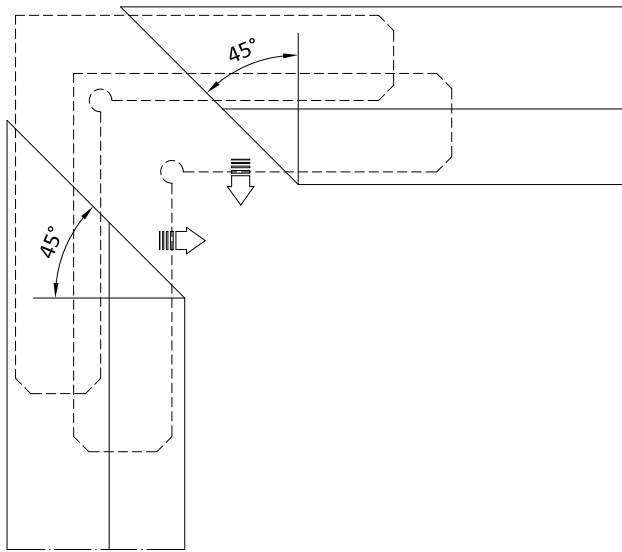

Profilo	Profile	Kit squadrette	Corner brackets set
Codice	Code	Codice	Code
PR2901-PR2901		AC 2801I	
PR2903-PR2903		AC 2803I	
PR2915-PR2915		AC 2803I	
PR2942-PR2942		AC 2801I	
PR2943-PR2943		AC 2843I	
PR2901-PR2942		AC 2801I	
PR2903-PR2942		AC 2801I	
PR2915-PR2942		AC 2801I	
PR2961-PR2961		AC 2801I	
PR2962-PR2962		AC 2862I	
PR2963-PR2963		AC 2803I	
PR2965-PR2965		AC 2865I	
PR2962-PR2963		AC 2801I	

Profilo	Profile	Kit squadrette	Corner brackets set
Codice	Code	Codice	Code
PR2965-PR2963		AC 2803I	
PR2971-PR2971		AC 2871I	
PR2972-PR2972		AC 2872I	
PR2973-PR2973		AC 2853I	
PR2974-PR2974		AC 2855I	
PR2975-PR2975		AC 2875I	
PR2991-PR2991		AC 2891I	
PR2992-PR2992		AC 2892I	
PR2993-PR2993		AC 2892I	
PR2995-PR2995		AC 2895I	

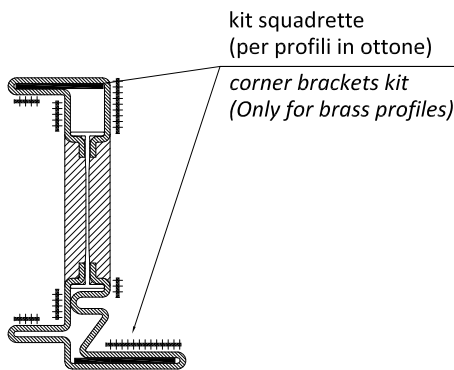
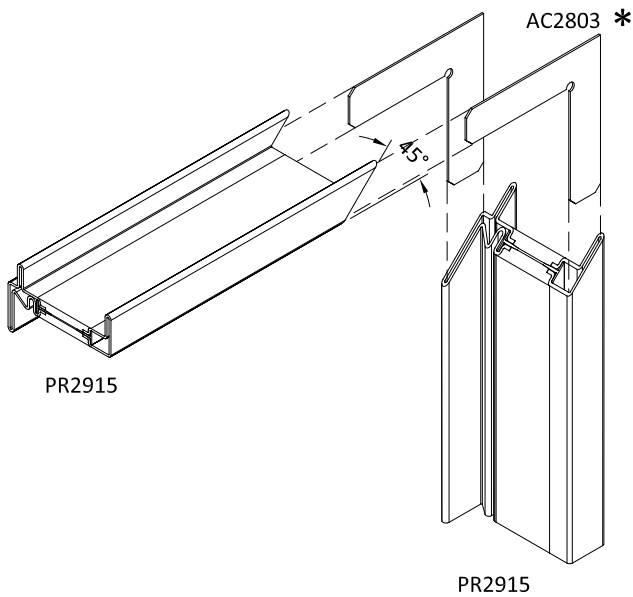

kit squadrette
(per profili in ottone)
corner brackets kit
(Only for brass profiles)

Ottone

Utilizzare le squadrette di allineamento, sigillare tutte le superfici di contatto tra i profili che non vanno saldate.

Saldare a TIG con materiale di riporto nelle zone indicate con ██████████

Brass

Use corner brackets, seal all surfaces in touch with profiles that are not to be seam-welded.

TIG welding with filler material in the areas indicated with ██████████

Acciaio zincato - Acciaio Corten - Acciaio inox

Saldare in continuo le superfici di contatto.

Galvanised steel - Cor-ten steel - Stainless steel

Seam-weld all contact surfaces.

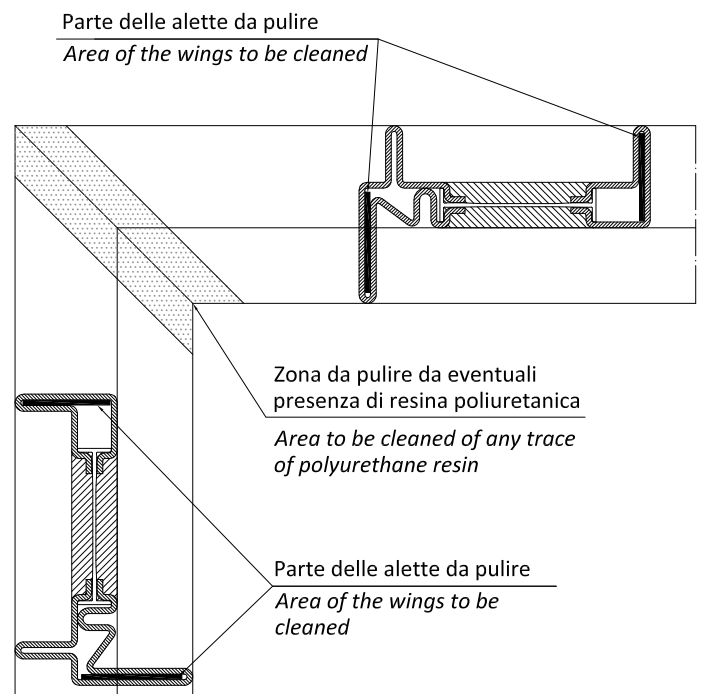
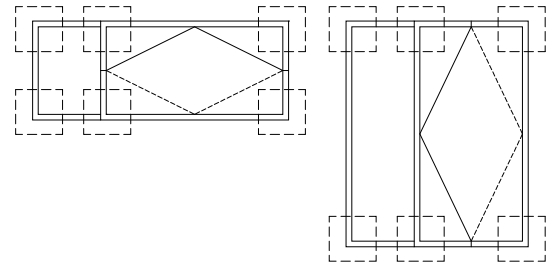

N.B. Prima di saldare l'angolo del profilo eliminare l'eventuale resina poliuretanicca presente all'interno dell'aletta scaldando leggermente il profilo stesso per circa 20 mm in modo da sciogliere la resina ed eliminare le impurità presenti

ATTN. Before welding the corner please remove any trace of polyurethane resin in the internal side of casin, heating the profile for ca. 20 mm to melt the resin and remove in this way all other impurities.

* Esempio "tipo" di giunzione angolare OS2 in OT67 indicativa per tutte le unioni angolari a 45°
Per scelta squadrette vedi tabella a pag. 4.4.1

* Example of corner connection for OS2 element in brass OT67 applicable to all 45° corner connection.
To choose the right corner bracket see table at page 4.4.1.

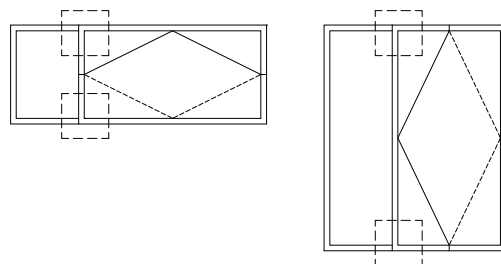
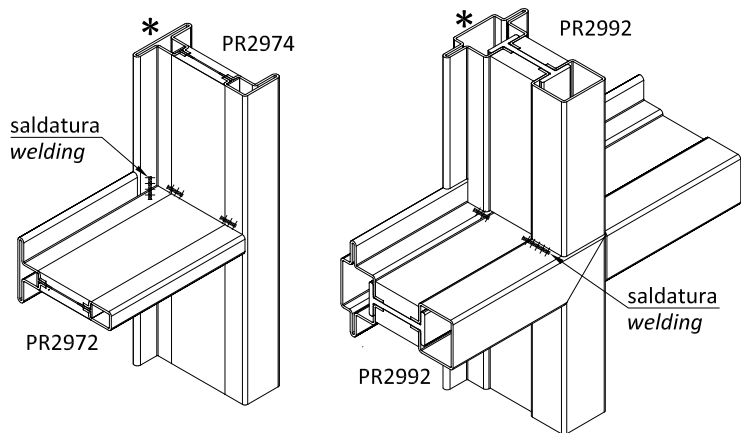

Ottone

Saldare a TIG con materiale di riporto nelle zone indicate con +++++

Brass

TIG welding with filler material in the areas indicated with +++++

Acciaio zincato - Acciaio Corten - Acciaio inox

Saldare in continuo le superfici di contatto.

Galvanised steel - Cor-ten steel - Stainless steel

Seam-weld all contact surfaces.

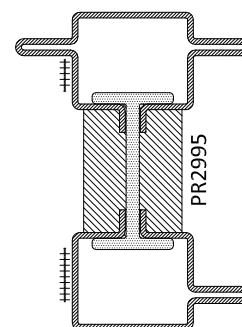
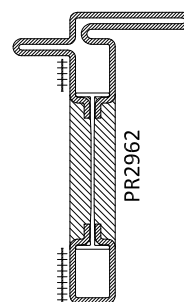
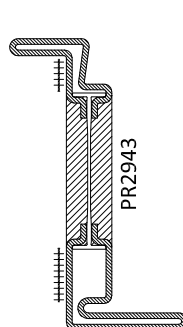
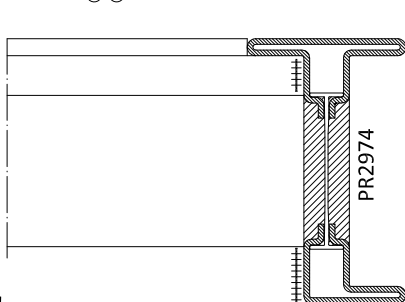
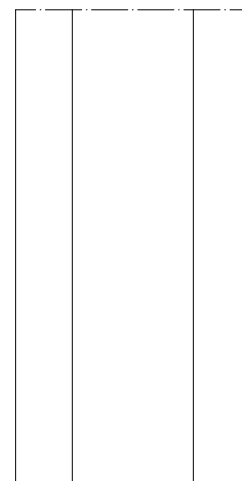
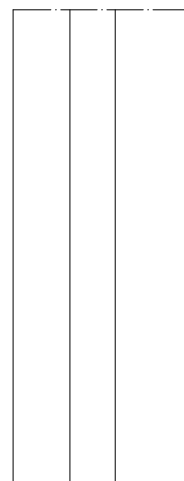
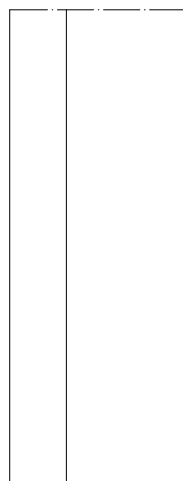
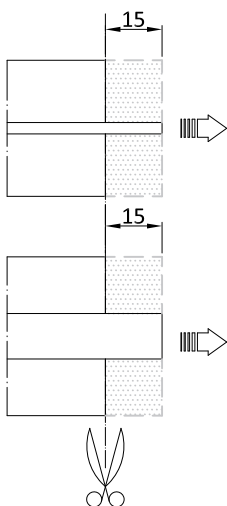
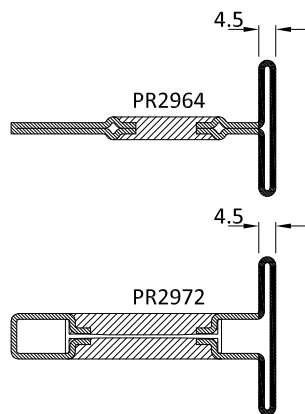
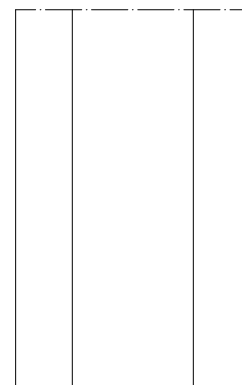
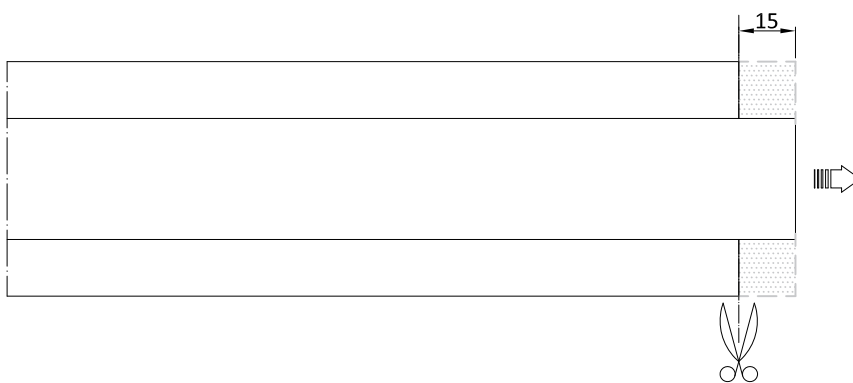
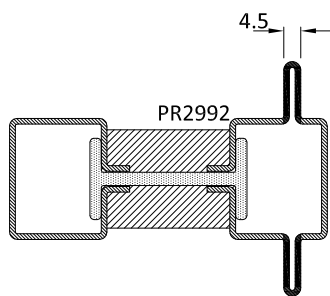

* Esempi "tipo" di giunzione a "T"

* Example of "T" connection for OS2

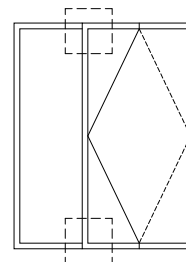
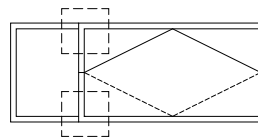
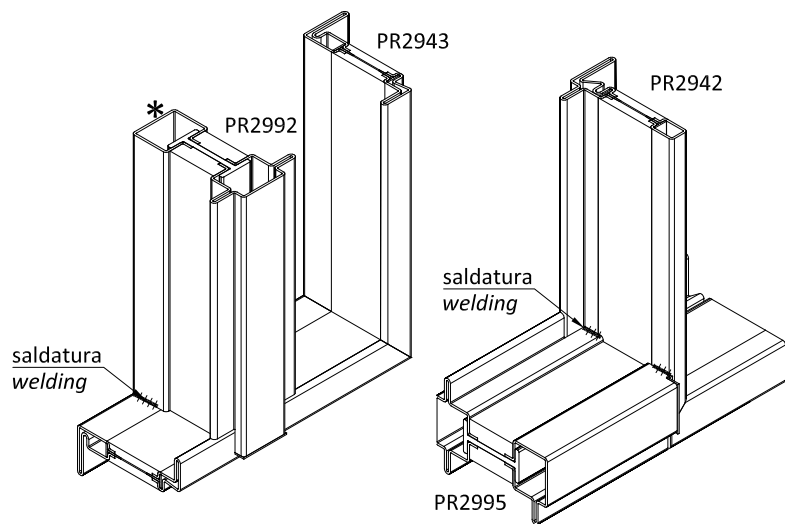

Ottone

Saldare a TIG con materiale di riporto nelle zone indicate con +++++

Brass

TIG welding with filler material in the areas indicated with +++++

Acciaio zincato - Acciaio Corten - Acciaio inox

Saldare in continuo le superfici di contatto.

Galvanised steel - Cor-ten steel - Stainless steel

Seam-weld all contact surfaces.

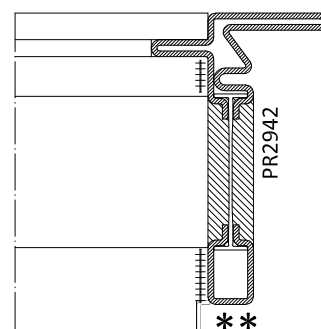
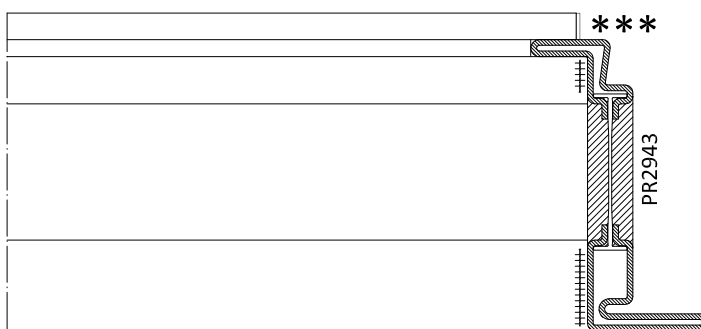
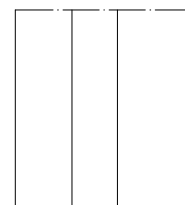
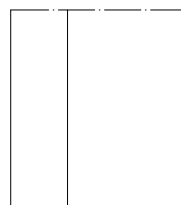
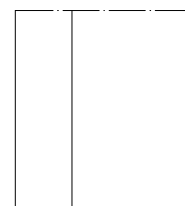
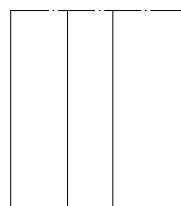
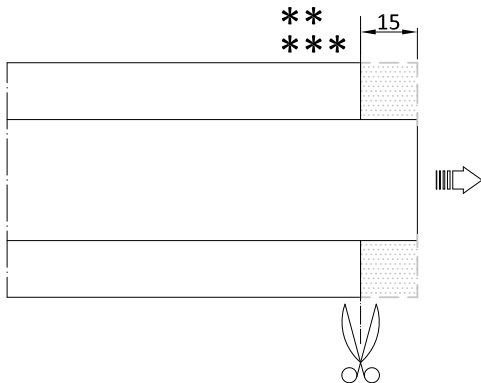
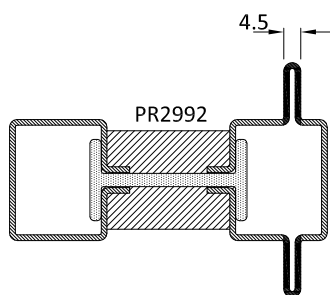
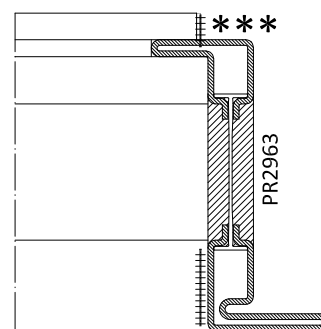
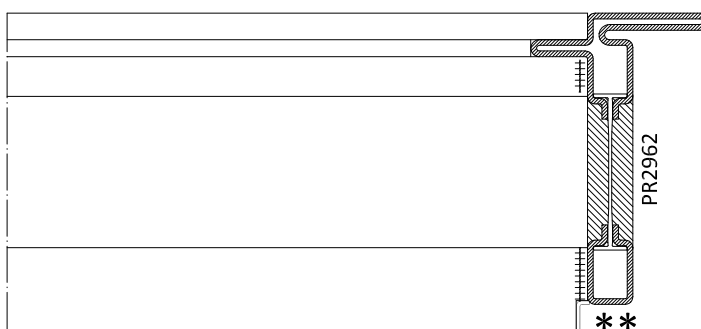

- * Esempi "tipo" di giunzione a "T"
- * Example of "T" connection for OS2
- ** Lavorazione pag. 4.3.2
- ** Processing pg. 4.3.2
- *** Lavorazione pag. 4.3.3

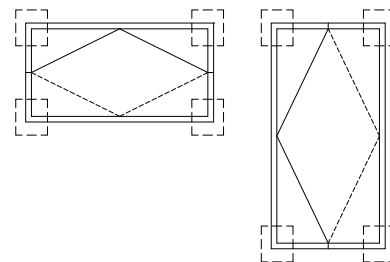

Acciaio zincato - Acciaio Corten - Acciaio inox

Saldare in continuo le superfici di contatto indicate con 

Galvanised steel - Cor-ten steel - Stainless steel

Seam-weld the shown areas with 

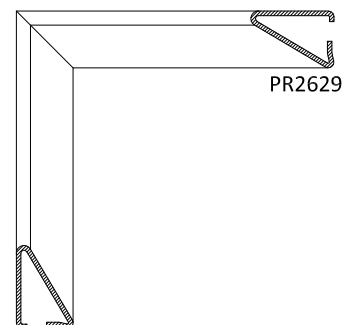
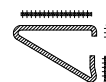
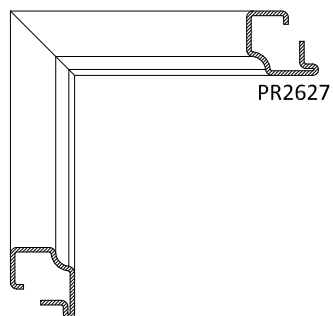
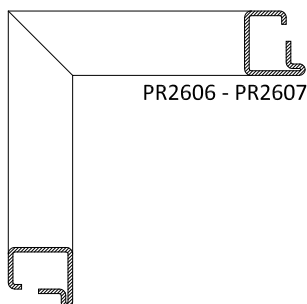

Ottone:

Saldare a TIG con materiale di riporto nelle zone indicate con 

Brass:

TIG welding with filler material in the areas indicated with 

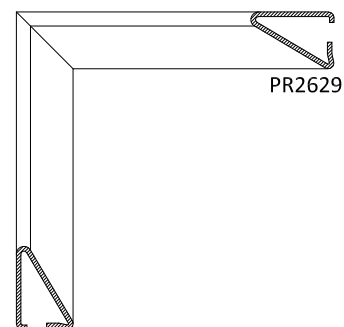
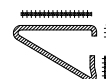
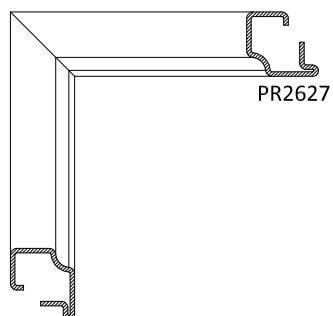
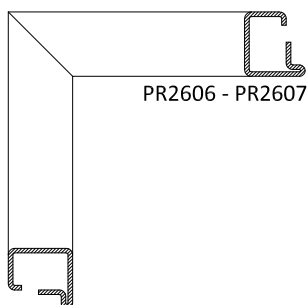

A Perno di rotazione snodo bilico
 B Elemento anta snodo bilico
 C Elemento intermedio snodo
 D Pattino lubrificante snodo
 E Elemento telaio snodo
 F Rinforzo fissaggio snodo
 G Vite A2 TSPEI M4 x 8 mm
 H Spina elastica INOX Ø 3 mm
 I Vite A2 TSPEI M4 x 30 mm
 L Boccola inserimento vite Ø 4.2 mm
 M Vite autofilettante TSP Ø 4.2 x 13 mm
 N Grano M6 x 25 mm punta conica
 O Cuscinetto (solo su bilico orizzontale)

A linchpin of pivot bearing
B pivot bearing on leaf
C intermediate element of pivot bearing
D lubricating runner of pivot bearing
E fixed pivot bearing on frame
F reinforcement fixing pivot bearing
G screw A2 TSPEI M4 x 8 mm
H elastic spin in stainless steel Ø 3 mm
I screw A2 TSPEI M4 x 30 mm
L Bushing for screw Ø 4.2 mm
M self-penetrating screws TSP Ø 4.2 x 13 mm
N Grub screw M6 x 25 mm conical point
O Bearing (only horizontal pivot)

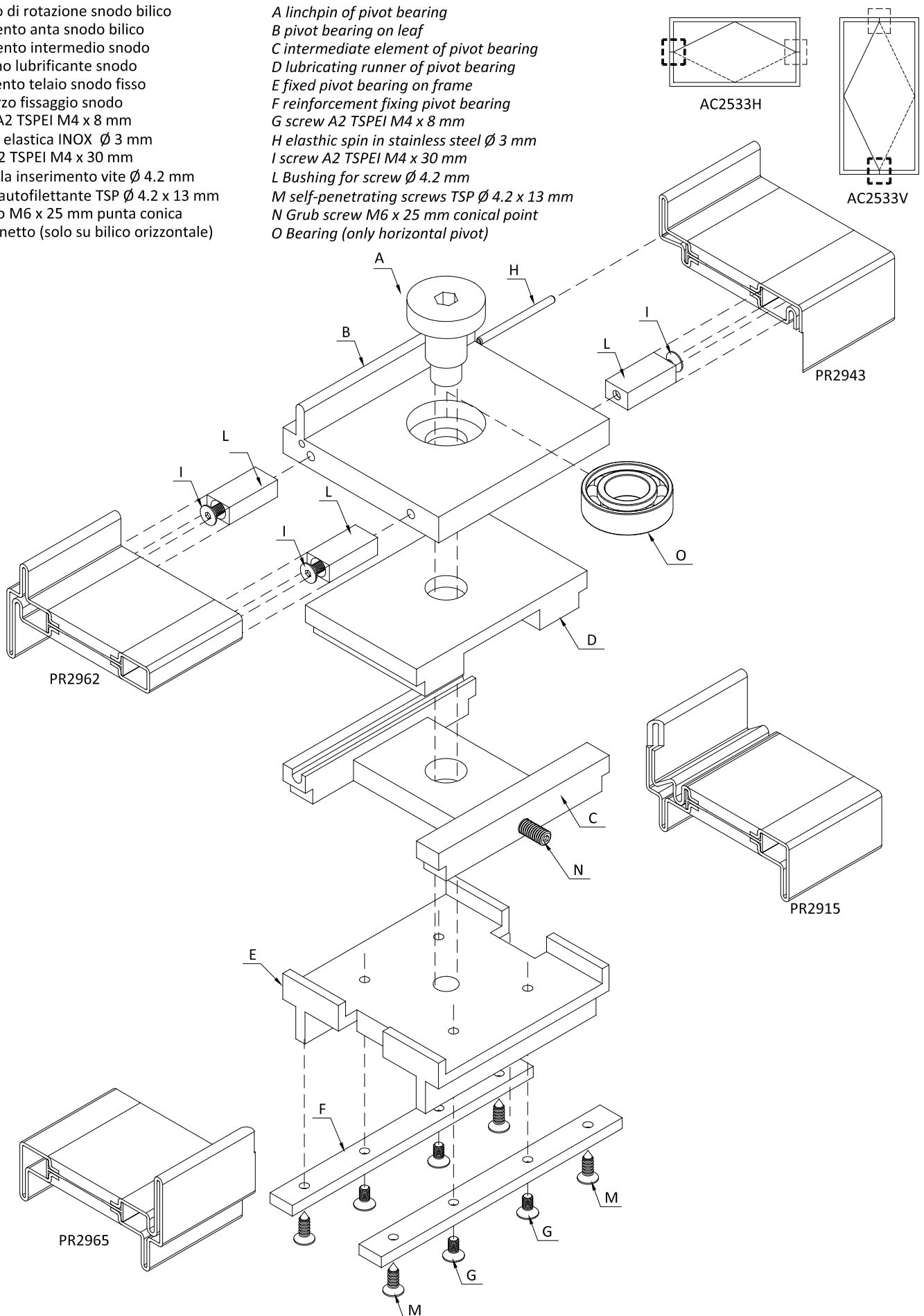

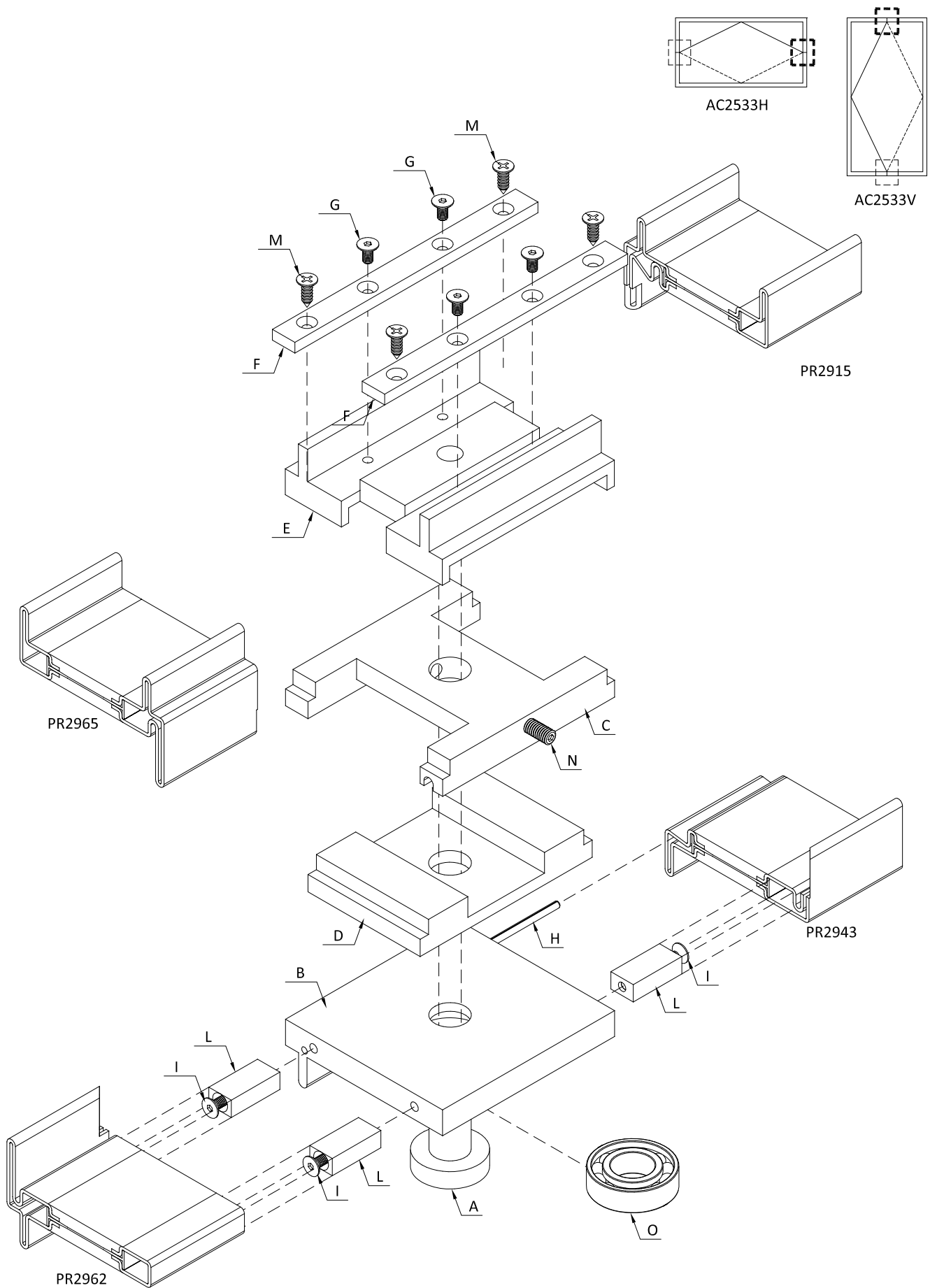

A Perno di rotazione snodo bilico
 B Elemento anta snodo bilico
 C Elemento intermedio snodo
 D Pattino lubrificante snodo
 E Elemento telaio snodo
 F Rinforzo fissaggio snodo
 G Vite A2 TSPEI M4 x 8 mm
 H Spina elastica INOX Ø 3 mm
 I Vite A2 TSPEI M4 x 30 mm
 L Boccola inserimento vite Ø 4.2 mm
 M Vite autofilettante TSP Ø 4.2 x 13 mm
 N Grano M6 x 25 mm punta conica
 O Cuscinetto (solo su bilico orizzontale)

A linchpin of pivot bearing
B pivot bearing on leaf
C intermediate element of pivot bearing
D lubricating runner of pivot bearing
E fixed pivot bearing on frame
F reinforcement fixing pivot bearing
G screw A2 TSPEI M4 x 8 mm
H elastic spin in stainless steel Ø 3 mm
I screw A2 TSPEI M4 x 30 mm
L Bushing for screw Ø 4.2 mm
M self-penetrating screws TSP Ø 4.2 x 13 mm
N Grub screw M6 x 25 mm conical point
O Bearing (only horizontal pivot)

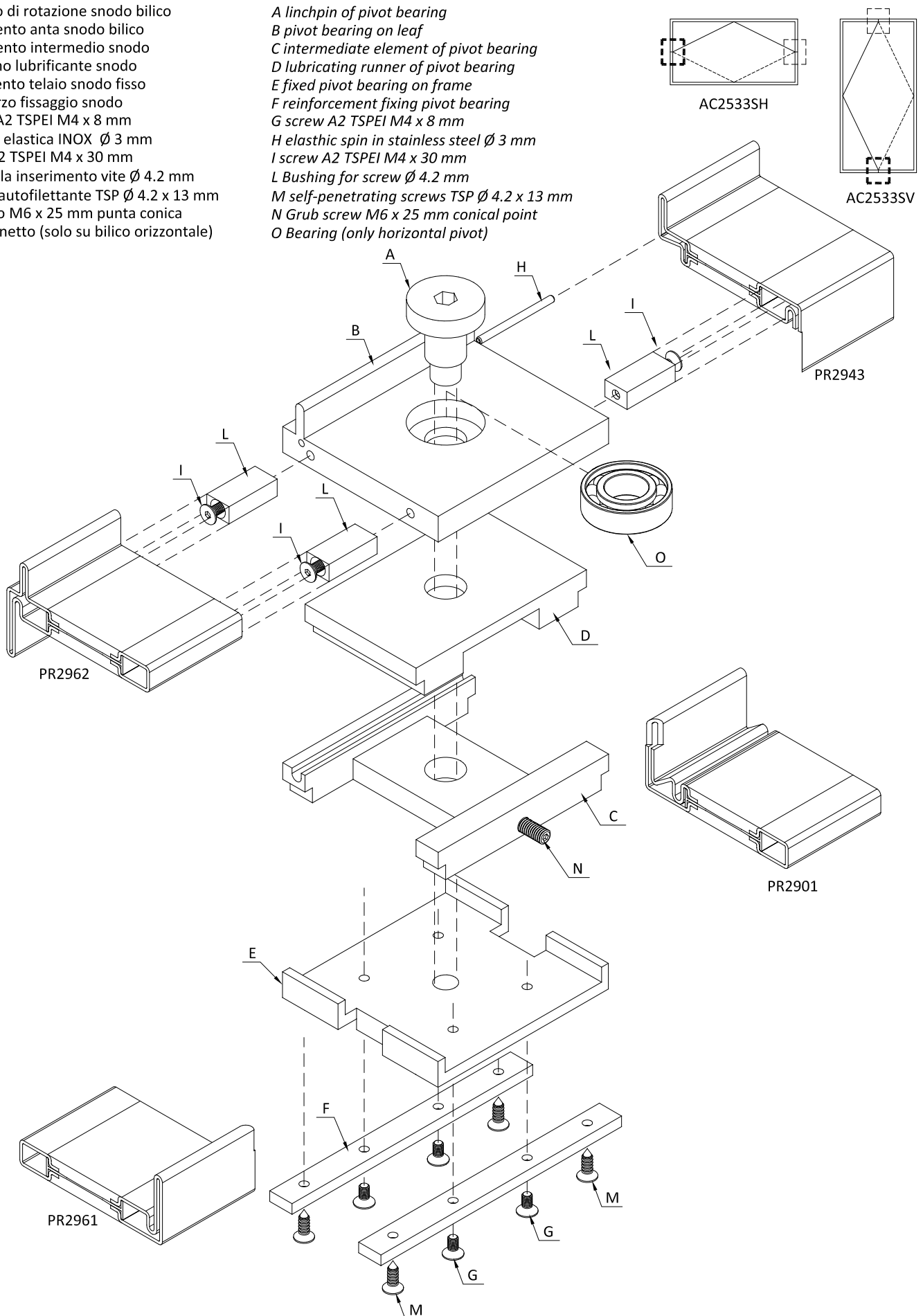

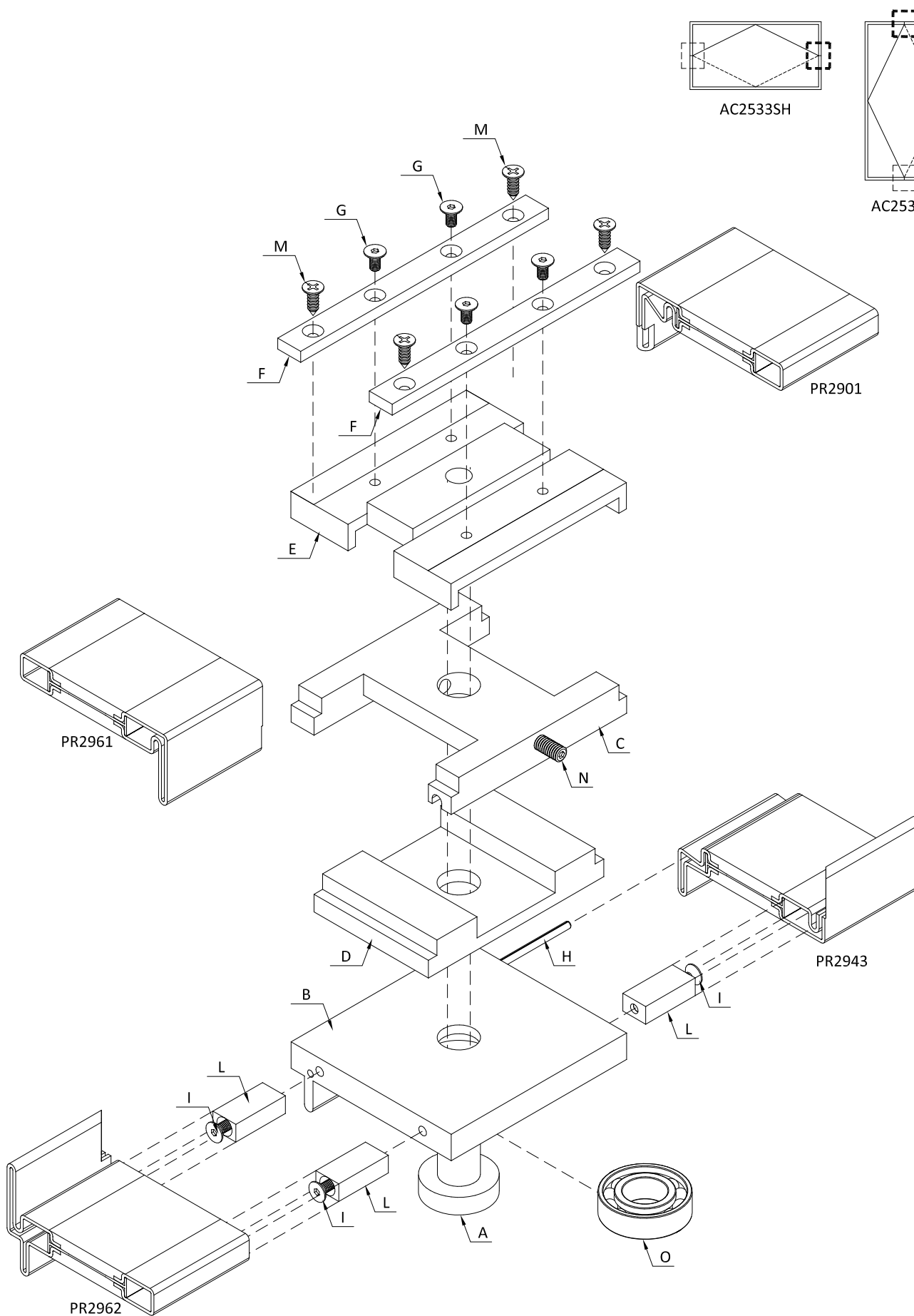

A Perno di rotazione snodo bilico
 B Elemento anta snodo bilico
 C Elemento intermedio snodo
 D Pattino lubrificante snodo
 E Elemento telaio snodo fisso
 F Rinforzo fissaggio snodo
 G Vite A2 TSPEI M4 x 8 mm
 H Spina elastica INOX Ø 3 mm
 I Vite A2 TSPEI M4 x 30 mm
 L Boccola inserimento vite Ø 4.2 mm
 M Vite autofilettante TSP Ø 4.2 x 13 mm
 N Grano M6 x 25 mm punta conica
 O Cuscinetto (solo su bilico orizzontale)

A linchpin of pivot bearing
B pivot bearing on leaf
C intermediate element of pivot bearing
D lubricating runner of pivot bearing
E fixed pivot bearing on frame
F reinforcement fixing pivot bearing
G screw A2 TSPEI M4 x 8 mm
H elastic spin in stainless steel Ø 3 mm
I screw A2 TSPEI M4 x 30 mm
L Bushing for screw Ø 4.2 mm
M self-penetrating screws TSP Ø 4.2 x 13 mm
N Grub screw M6 x 25 mm conical point
O Bearing (only horizontal pivot)

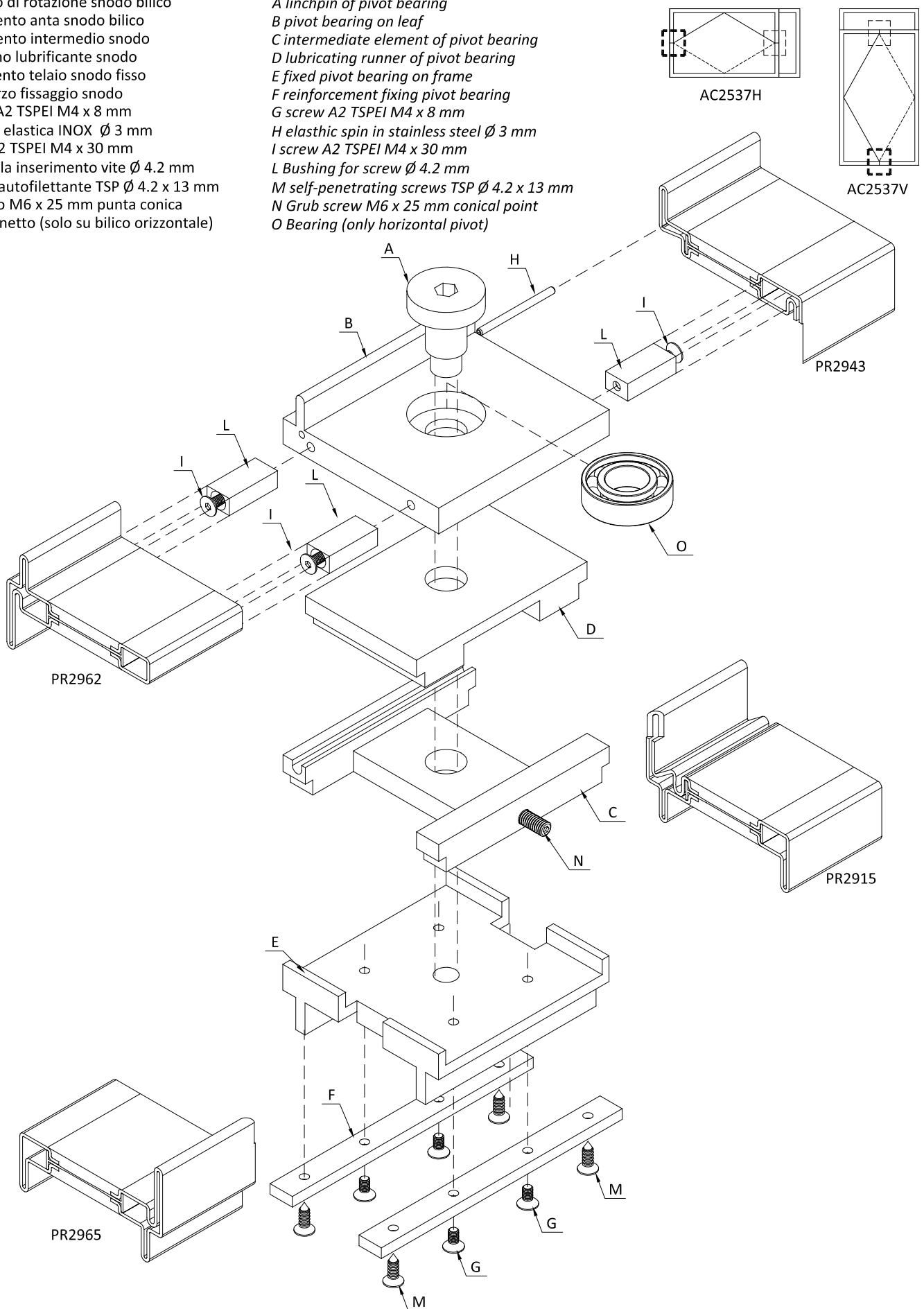

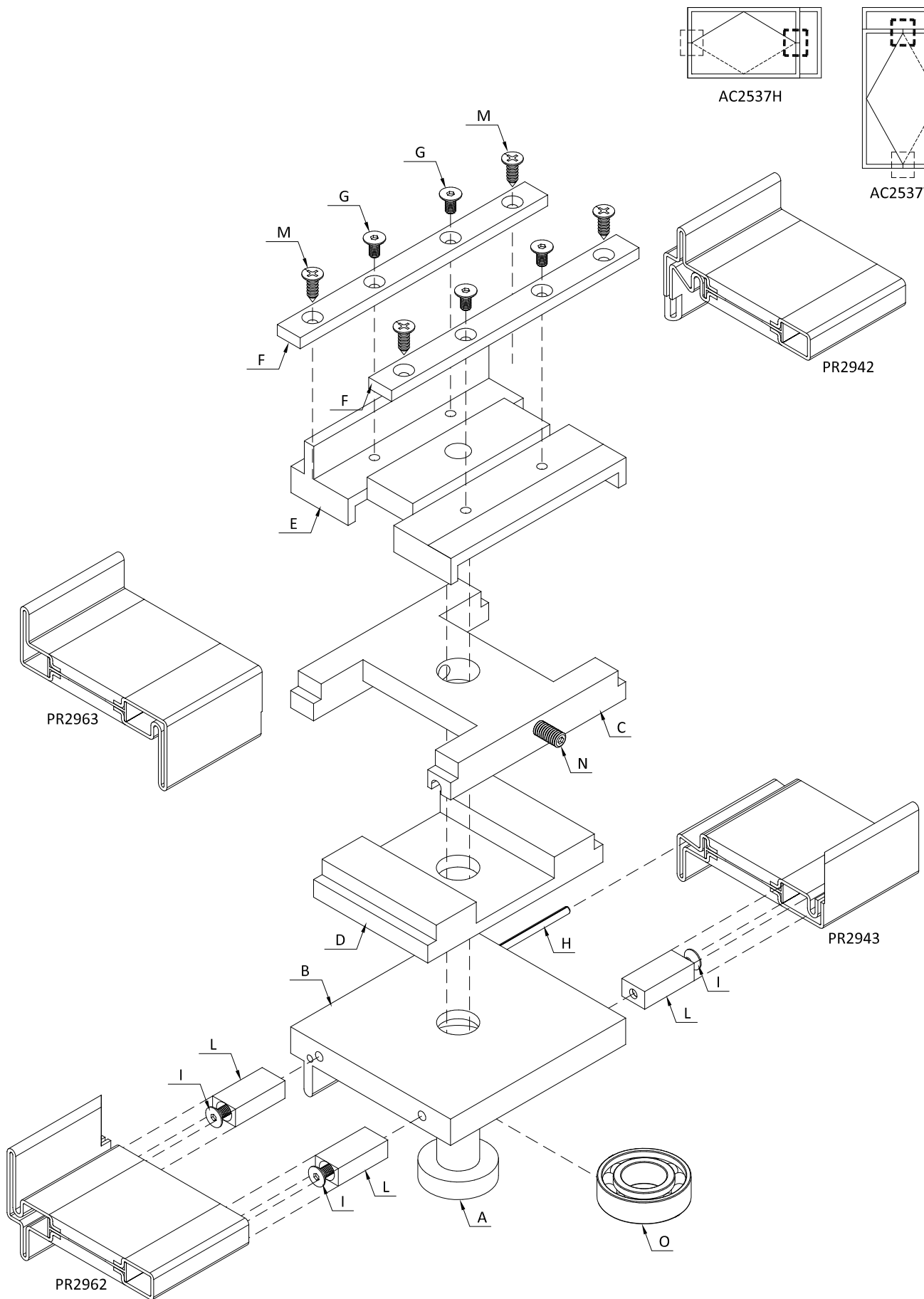

A Perno di rotazione snodo bilico
 B Elemento anta snodo bilico
 C Elemento intermedio snodo
 D Pattino lubrificante snodo
 E Elemento telaio snodo fisso
 F Rinforzo fissaggio snodo
 G Vite A2 TSPEI M4 x 8 mm
 H Spina elastica INOX Ø 3 mm
 I Vite A2 TSPEI M4 x 30 mm
 L Boccola inserimento vite Ø 4.2 mm
 M Vite autofilettante TSP Ø 4.2 x 13 mm
 N Grano M6 x 25 mm punta conica
 O Cuscinetto (solo su bilico orizzontale)

A linchpin of pivot bearing
B pivot bearing on leaf
C intermediate element of pivot bearing
D lubricating runner of pivot bearing
E fixed pivot bearing on frame
F reinforcement fixing pivot bearing
G screw A2 TSPEI M4 x 8 mm
H elastic spin in stainless steel Ø 3 mm
I screw A2 TSPEI M4 x 30 mm
L Bushing for screw Ø 4.2 mm
M self-penetrating screws TSP Ø 4.2 x 13 mm
N Grub screw M6 x 25 mm conical point
O Bearing (only horizontal pivot)

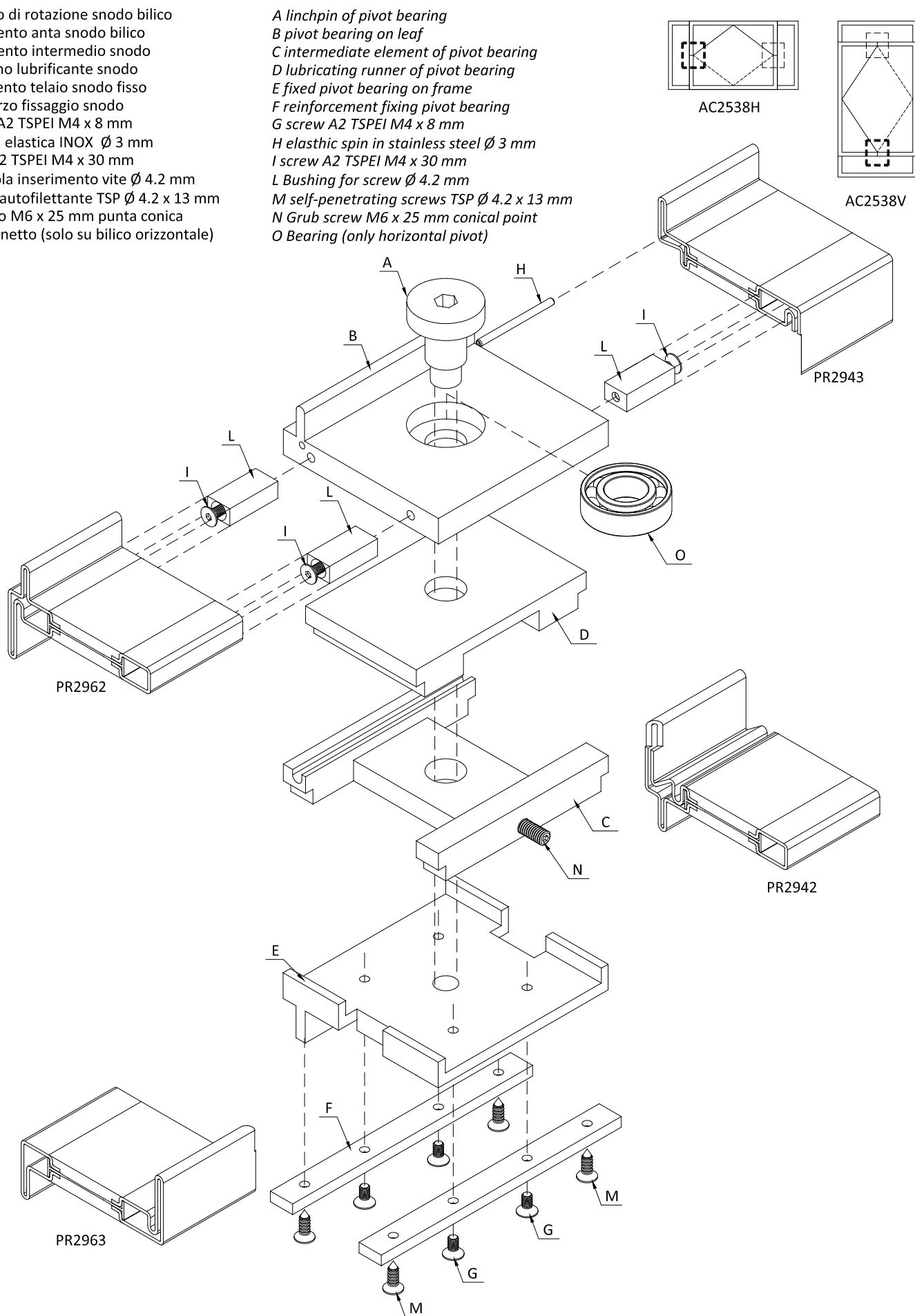

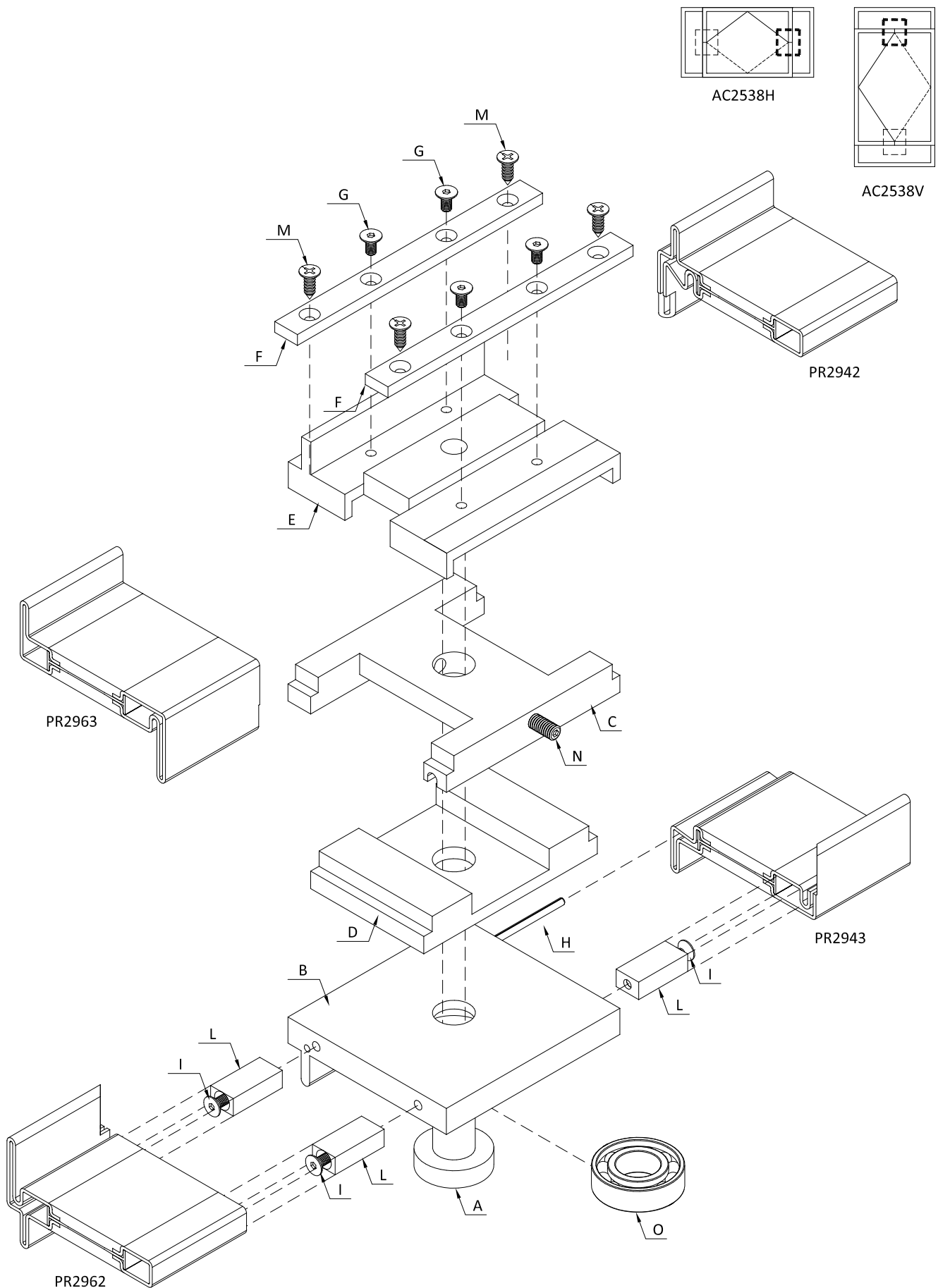

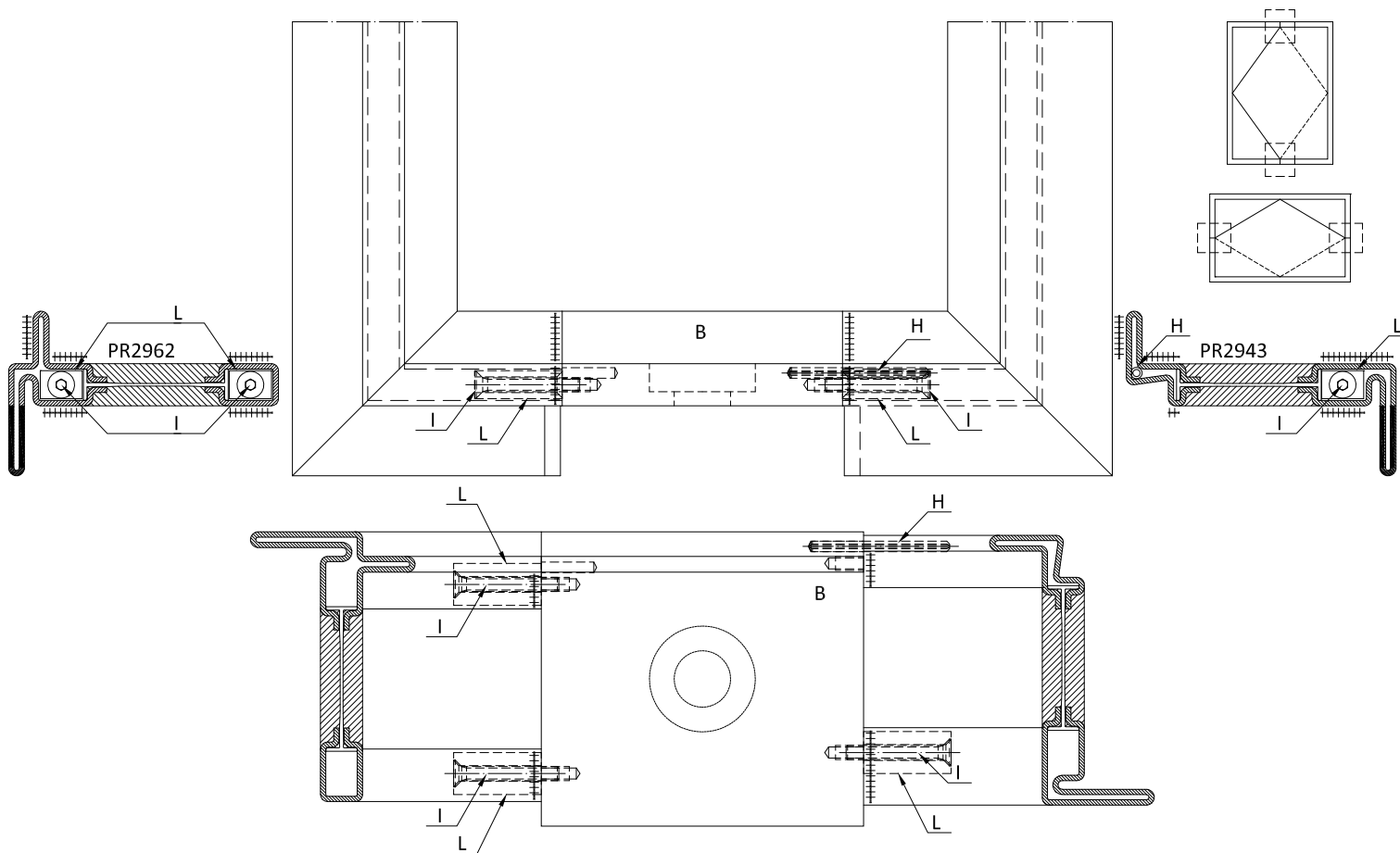

Saldare a TIG con materiale di riporto nelle zone indicate con +++++

TIG welding with filler material in the areas indicated with +++++

- B Elemento anta snodo bilico
- H Spina elastica INOX Ø 3 mm
- I Vite A2 TSPEI M4 x 30 mm
- L Boccola inserimento vite Ø 4.2 mm

- B pivot bearing on leaf
- H elastic pin in stainless steel Ø 3 mm
- I screw A2 TSPEI M4 x 30 mm
- L Bushing for screw Ø 4.2 mm

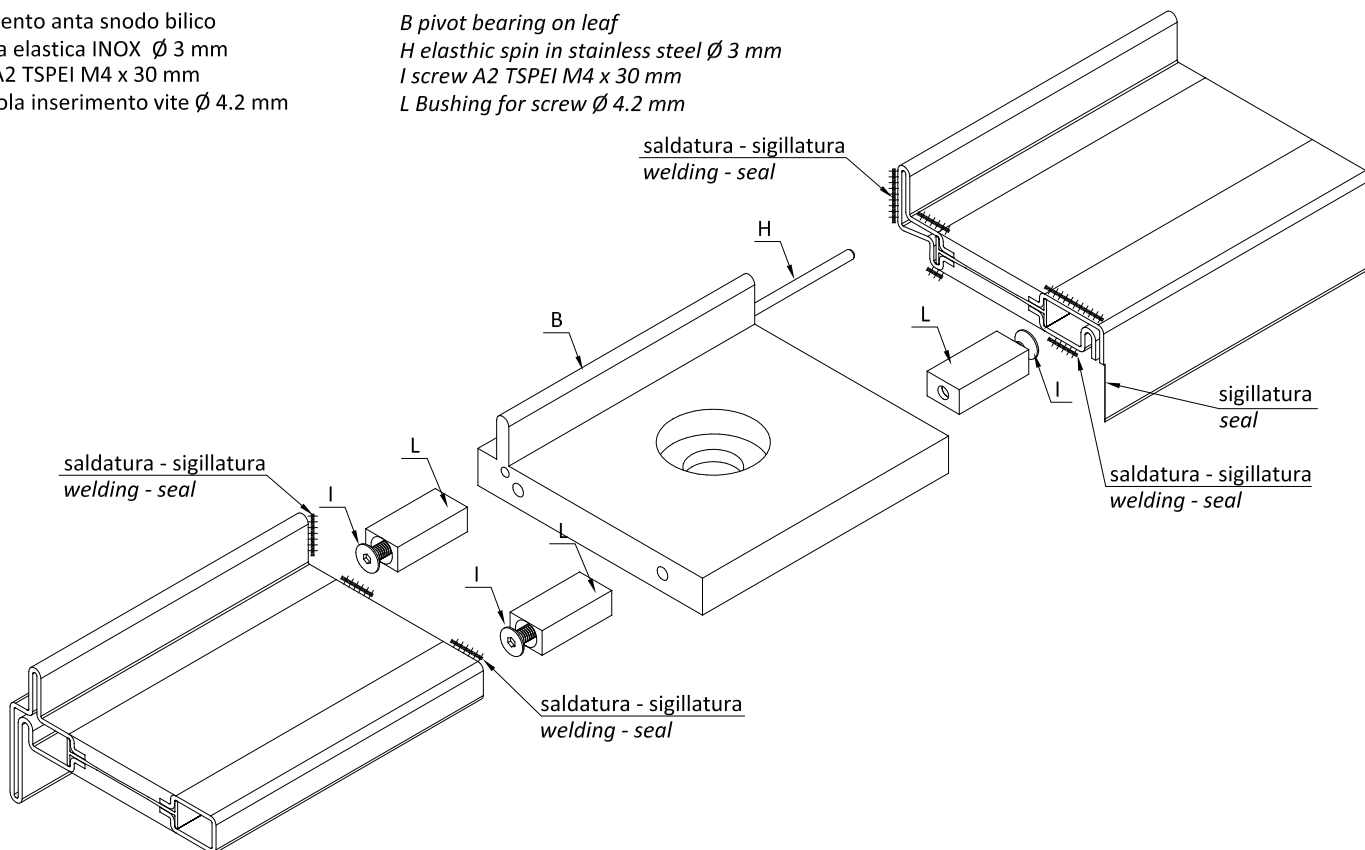

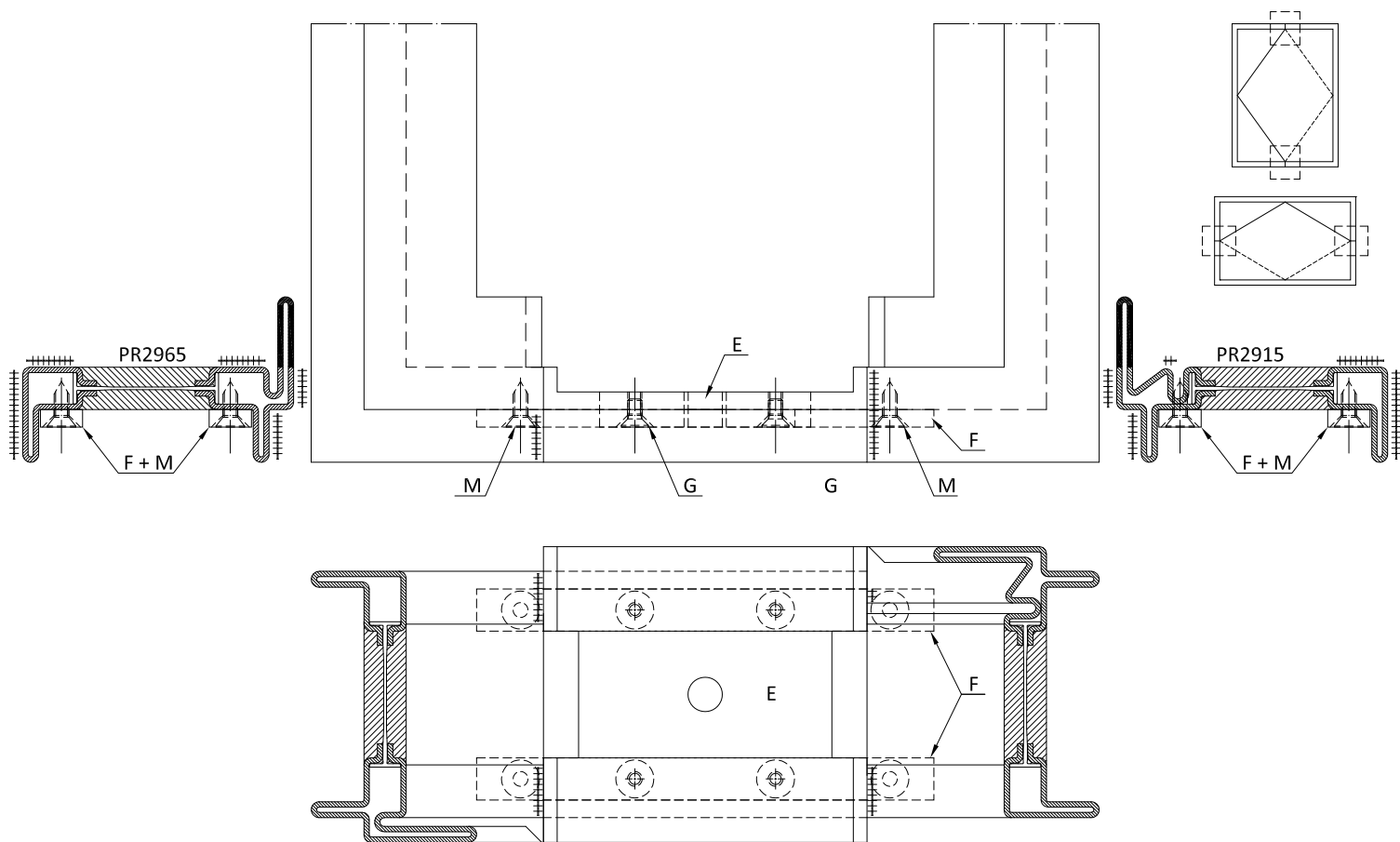

Saldare a TIG con materiale di riporto nelle zone indicate con

TIG welding with filler material in the areas indicated with

- E Elemento telaio snodo fisso
- F Rinforzo fissaggio snodo
- G Vite A2 TSPEI M4 x 8 mm
- M Vite autofilettante TSP Ø 4.2 x 13 mm

- E fixed pivot bearing on frame
- F reinforcement fixing pivot bearing
- G screw A2 TSPEI M4 x 8 mm
- M self-penetrating screws TSP Ø 4.2 x 13 mm

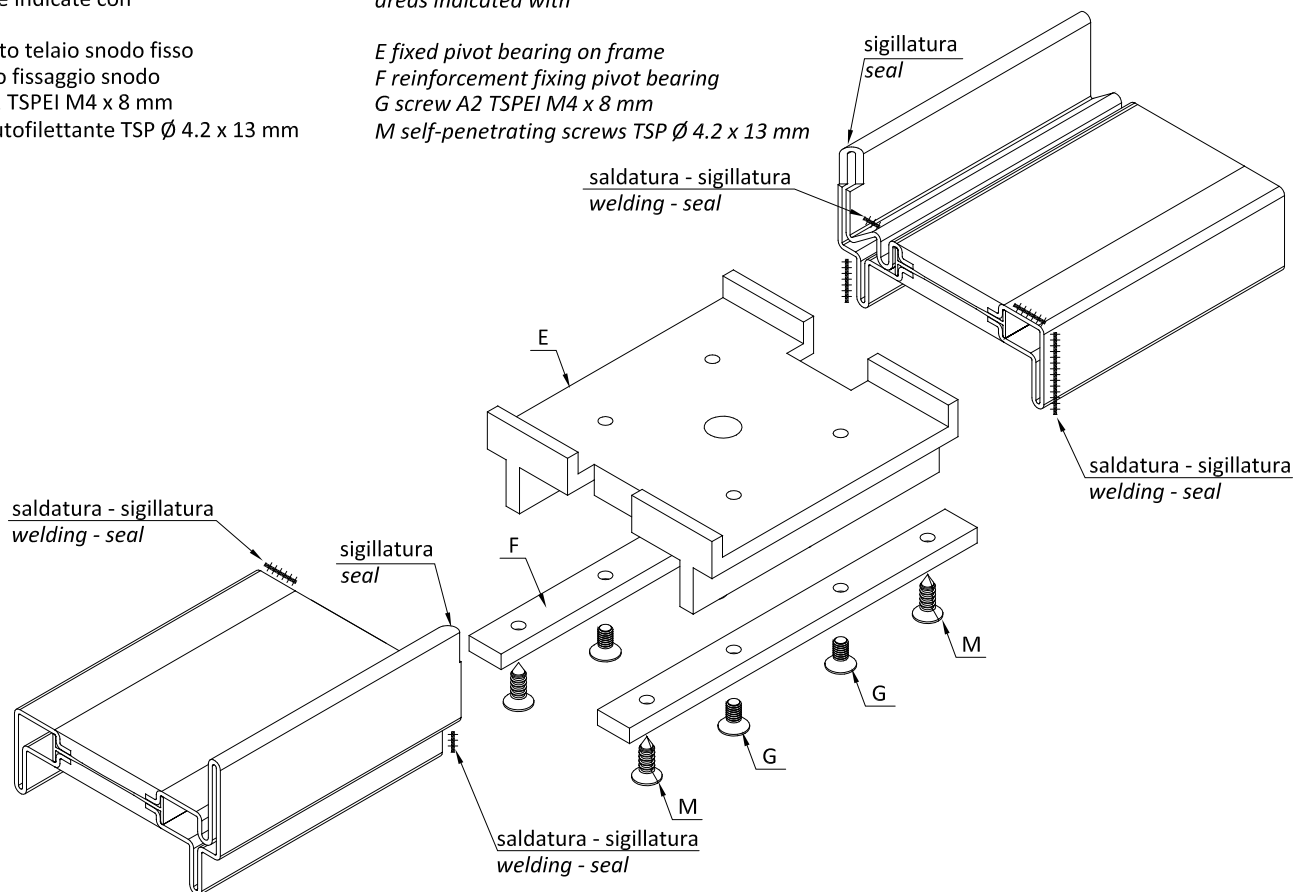

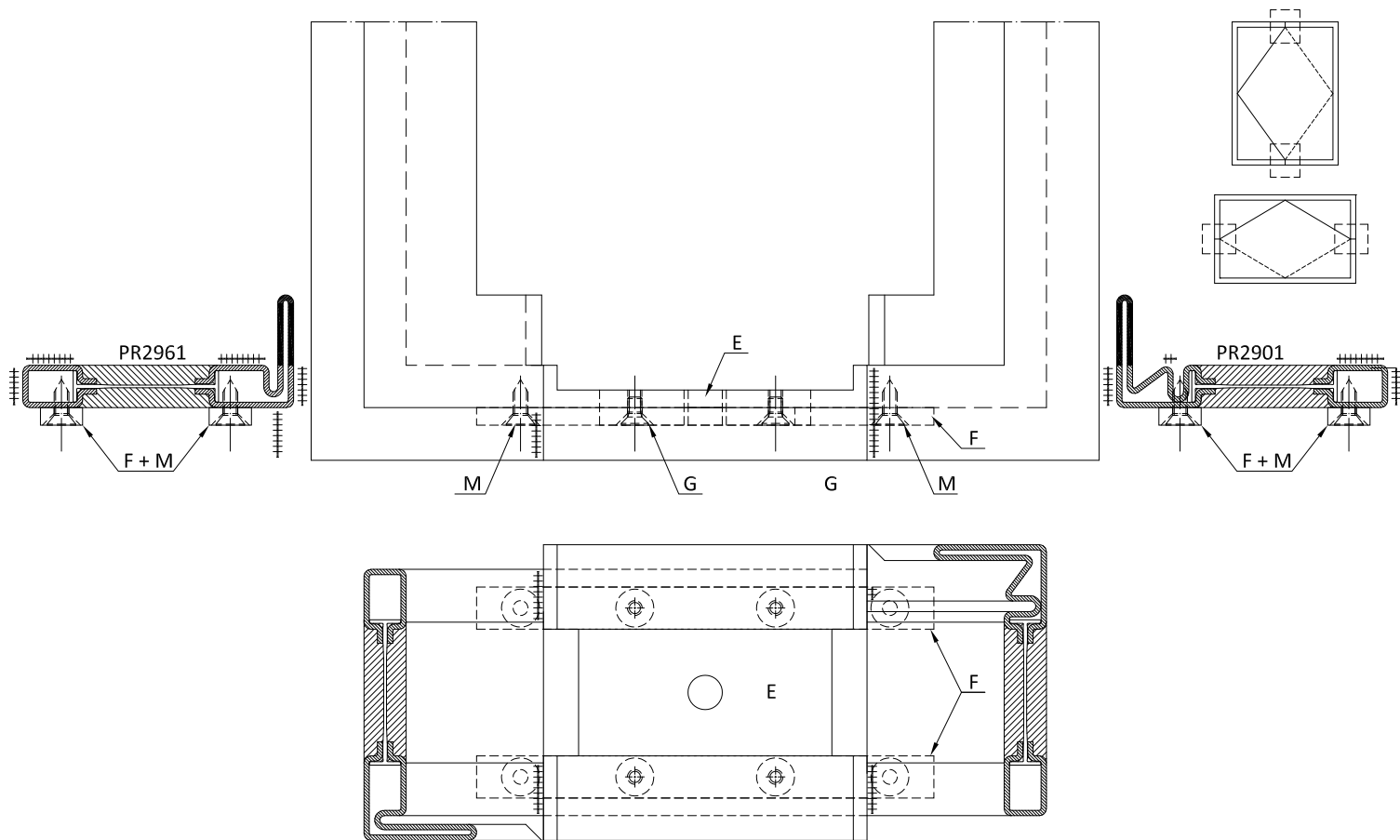

Saldare a TIG con materiale di riporto nelle zone indicate con

TIG welding with filler material in the areas indicated with

- E Elemento telaio snodo fisso
- F Rinforzo fissaggio snodo
- G Vite A2 TSPEI M4 x 8 mm
- M Vite autofilettante TSP Ø 4.2 x 13 mm

- E fixed pivot bearing on frame
- F reinforcement fixing pivot bearing
- G screw A2 TSPEI M4 x 8 mm
- M self-penetrating screws TSP Ø 4.2 x 13 mm

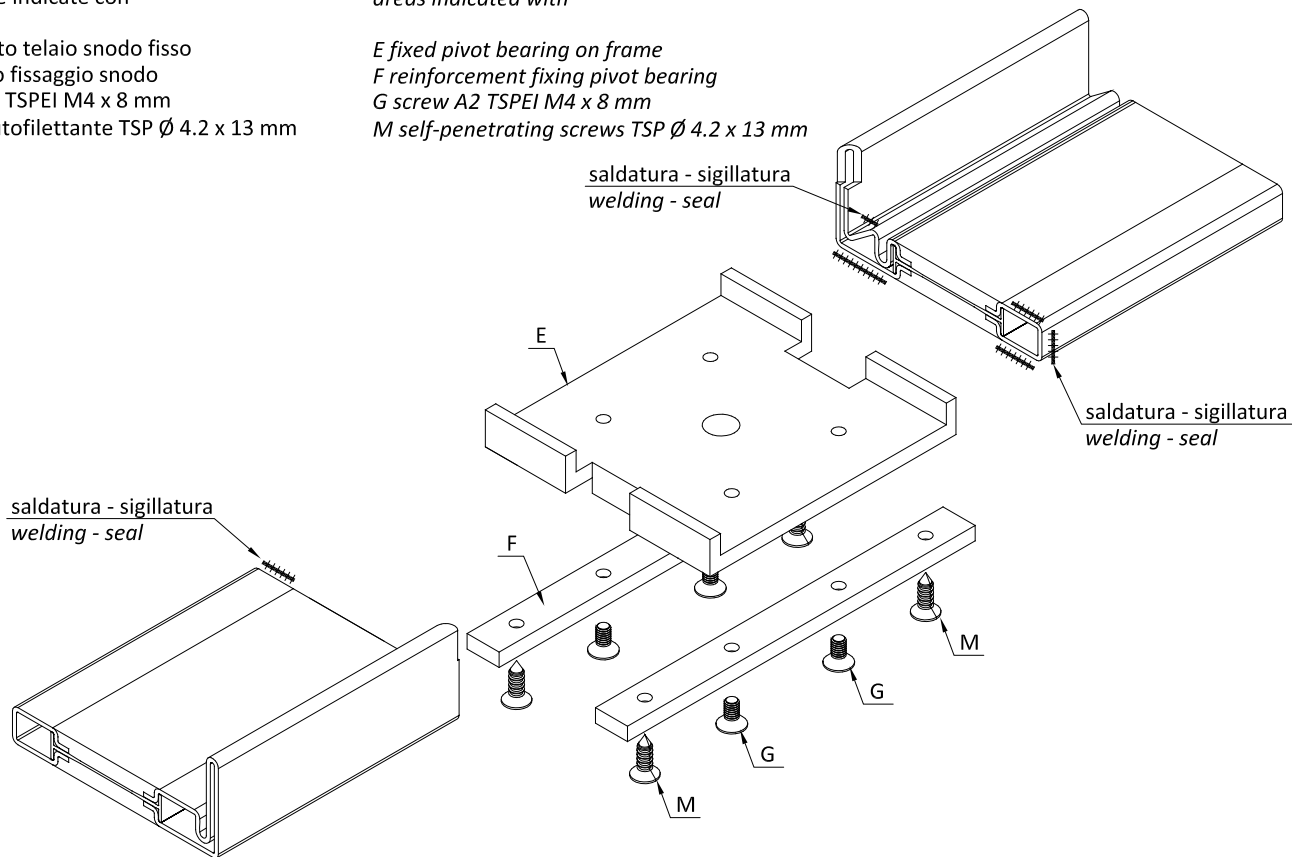

A Perno di rotazione snodo bilico
 B Elemento anta snodo bilico
 C Elemento intermedio snodo
 D Pattino lubrificante snodo
 E Elemento telaio snodo fisso
 F Rinforzo fissaggio snodo
 G Vite A2 TSPEI M4 x 8 mm
 H Spina elastica INOX Ø 3 mm
 I Vite A2 TSPEI M4 x 30 mm
 L Boccola inserimento vite Ø 4.2 mm
 M Vite autofilettante TSP Ø 4.2 x 13 mm
 N Grano M6 x 25 mm punta conica
 O Cuscinetto (solo su bilico orizzontale)

A linchpin of pivot bearing
B pivot bearing on leaf
C intermediate element of pivot bearing
D lubricating runner of pivot bearing
E fixed pivot bearing on frame
F reinforcement fixing pivot bearing
G screw A2 TSPEI M4 x 8 mm
H elastic spin in stainless steel Ø 3 mm
I screw A2 TSPEI M4 x 30 mm
L Bushing for screw Ø 4.2 mm
M self-penetrating screws TSP Ø 4.2 x 13 mm
N Grub screw M6 x 25 mm conical point
O Bearing (only horizontal pivot)

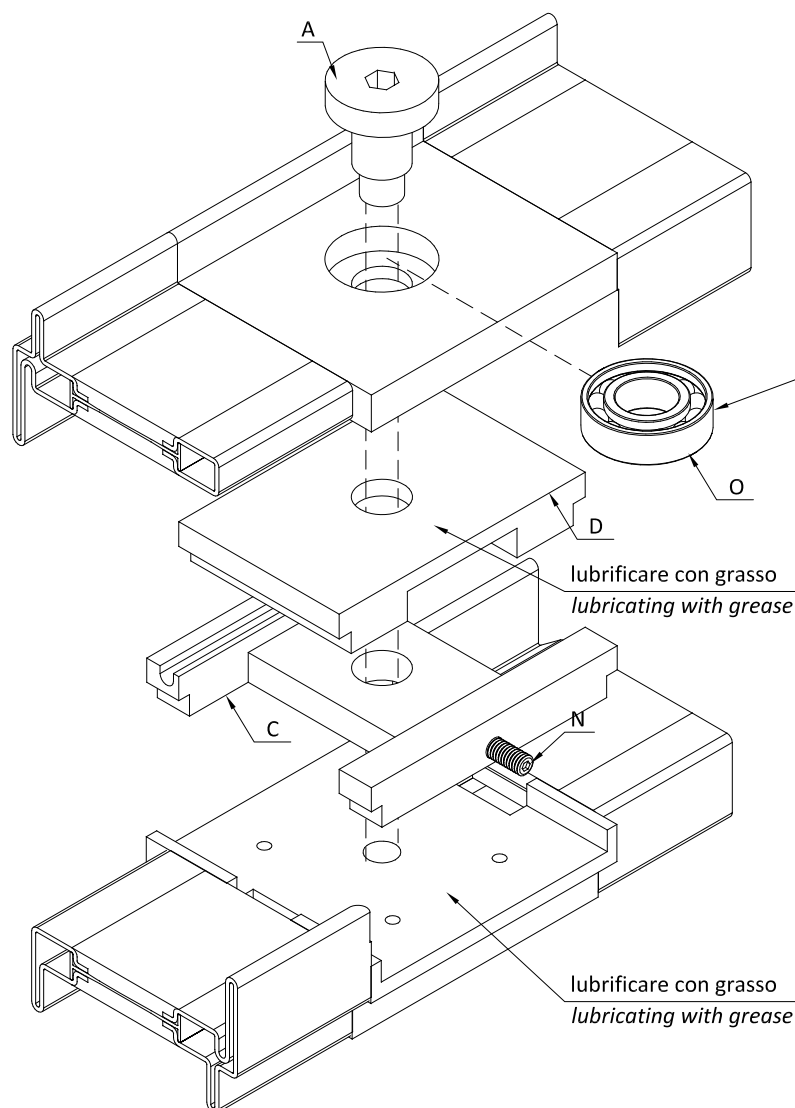
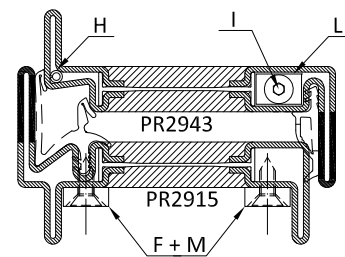
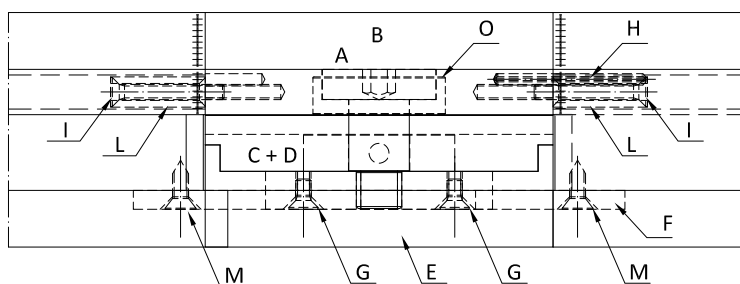
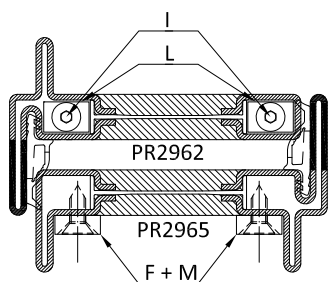
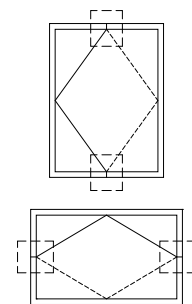

A Perno di rotazione snodo bilico
 B Elemento anta snodo bilico
 C Elemento intermedio snodo
 D Pattino lubrificante snodo
 E Elemento telaio snodo fisso
 F Rinforzo fissaggio snodo
 G Vite A2 TSPEI M4 x 8 mm
 H Spina elastica INOX Ø 3 mm
 I Vite A2 TSPEI M4 x 30 mm
 L Boccola inserimento vite Ø 4.2 mm
 M Vite autofilettante TSP Ø 4.2 x 13 mm
 N Grano M6 x 25 mm punta conica
 O Cuscinetto (solo su bilico orizzontale)

A linchpin of pivot bearing
B pivot bearing on leaf
C intermediate element of pivot bearing
D lubricating runner of pivot bearing
E fixed pivot bearing on frame
F reinforcement fixing pivot bearing
G screw A2 TSPEI M4 x 8 mm
H elastic spin in stainless steel Ø 3 mm
I screw A2 TSPEI M4 x 30 mm
L Bushing for screw Ø 4.2 mm
M self-penetrating screws TSP Ø 4.2 x 13 mm
N Grub screw M6 x 25 mm conical point
O Bearing (only horizontal pivot)

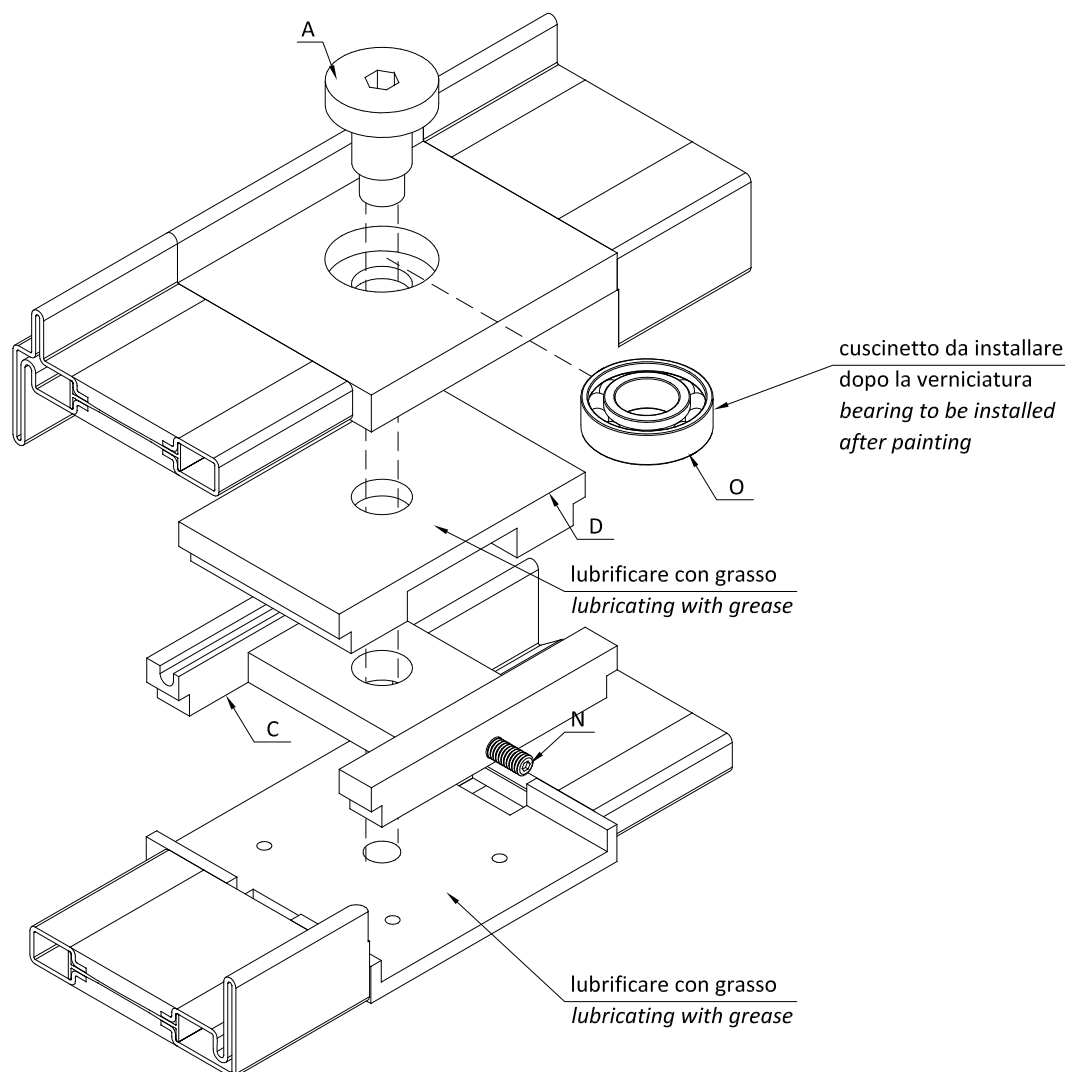
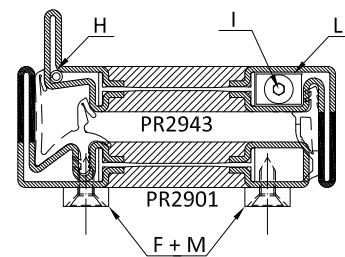
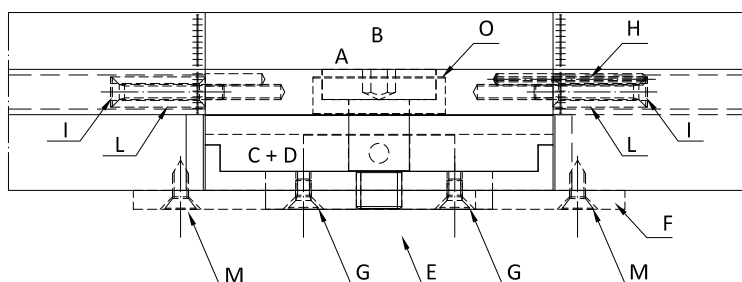
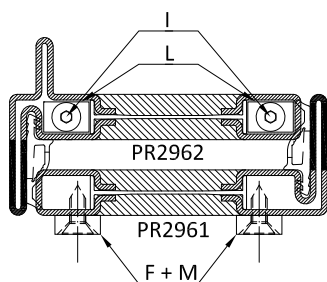
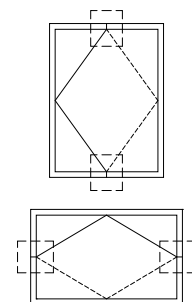

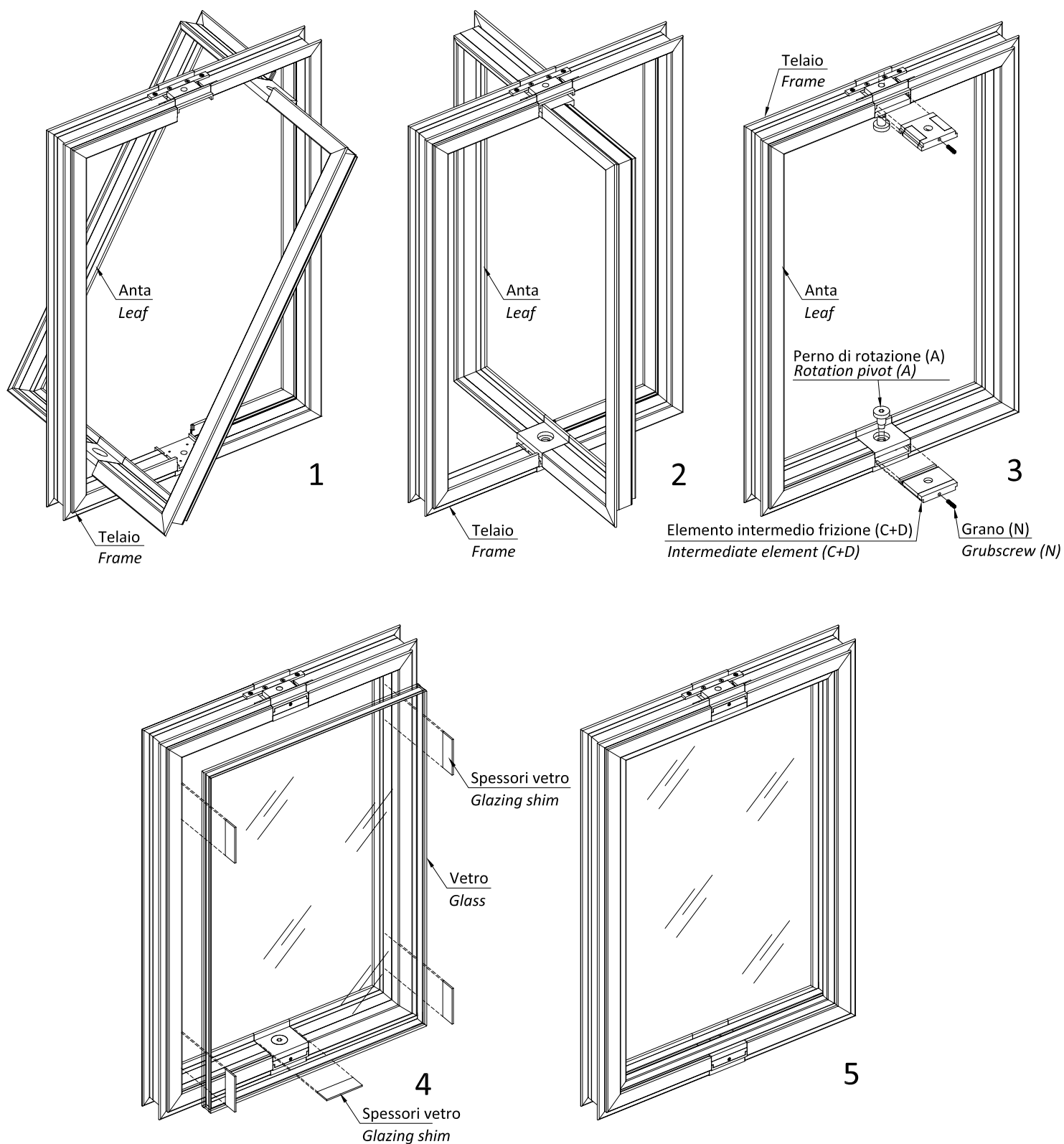

1 Inserire l'anta inclinata all'interno del telaio.

2 allineare verticalmente l'anta rispetto all'asse dello snodo bilico.

3 chiudere l'anta; inserire l'elemento intermedio (C+D) lubrificando con grasso della frizione e il perno (A) fissandolo con il grano (N) in dotazione.

4 Inserire il vetro avendo cura del corretto posizionamento degli spessori.

5 inserire il fermavetro.

1 Insert the leaf (inclined) in the frame

2 align vertically the leaf with the pivot bearing's axis

3 close the leaf; insert the intermediate element (C+D) lubricating with grease of pivot bearing and the linchpin (A) fixing it with the grub screw (N)

4 install the glass looking at the correct position of glass shims

5 install the glazing bead

- 1) Eseguire i fori come da disegno (lavorazione effettuabile con maschera AT2618).
- 2) Posizionare lo scarico acqua e sigillare fissare con viti in dotazione Inox A2.
- 3) Posizionare la guarnizione di giunto centrale e gli angoli vulcanizzati, incollare gli angoli alla guarnizione a mezzo di colla ciano-acrilica.
- 4) Sigillare per tutta la lunghezza la base inferiore e per 150 mm in altezza il telaio.

- 1) Drill the holes as shown in the diagram (using jig AT2618).
- 2) Position the water drain, seal and secure with the supplied A2 stainless screw.
- 3) Position the central weather strip and vulcanised corner, glue the corners to the weathers strip using cyanoacrylate glue.
- 4) Seal the entire lower base of the frame and vertically for 150 mm

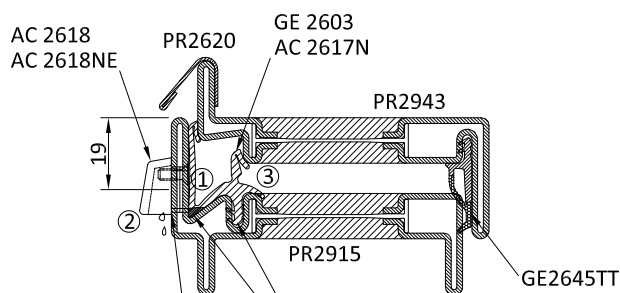
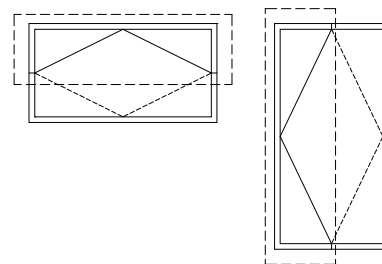

sigillare per tutta la lunghezza la base inferiore e per 150 mm in altezza il telaio.
seal the entire base of the frame and vertically for 150 mm

sigillare il perimetro dello scarico acqua
seal the perimeter of the water drip

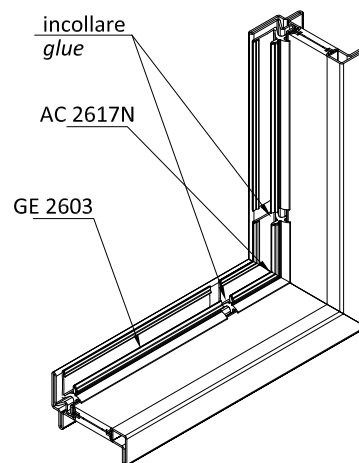

incollare gli angoli vulcanizzati AC2617N alla guarnizione con colla cianoacrilica
glue the AC2617N vulcanised corner to the gasket using cyanoacrylate glue

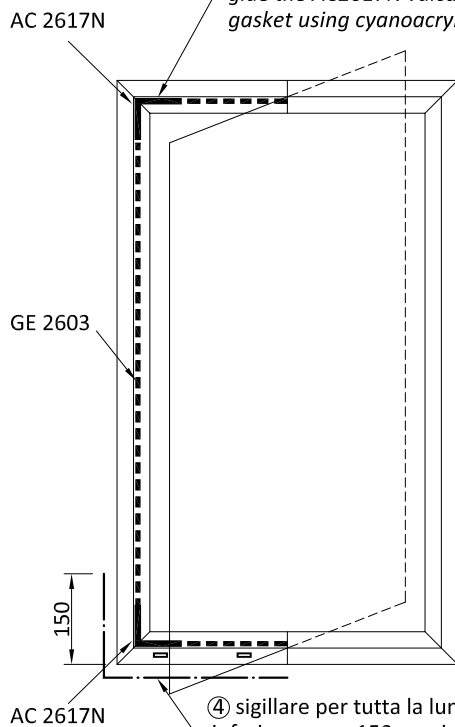

- ④ sigillare per tutta la lunghezza la base inferiore e per 150 mm in altezza il telaio
- ④ seal the entire base of the frame and vertically for 150 mm

incollare gli angoli vulcanizzati AC2617N alla guarnizione con colla cianoacrilica
glue the AC2617N vulcanised corner to the gasket using cyanoacrylate glue

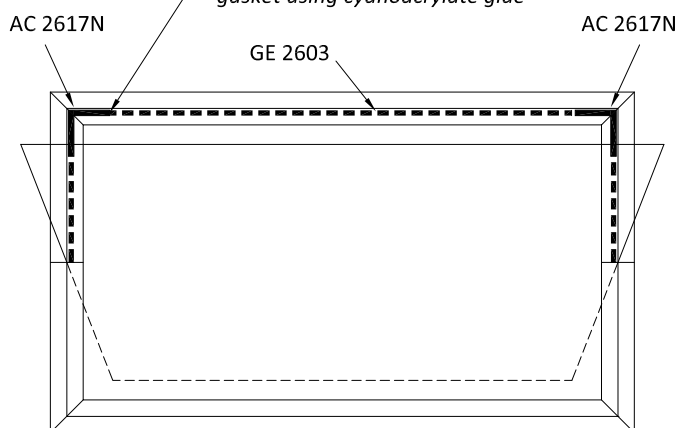

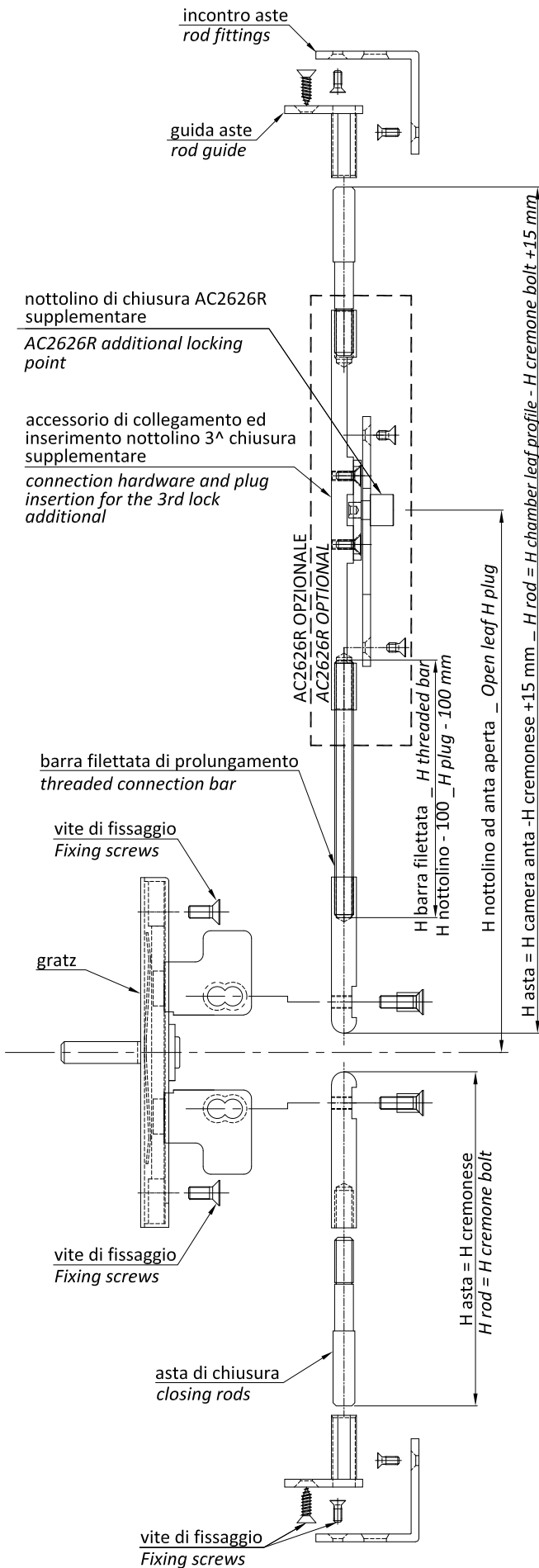

- 1) Avvitare le aste di chiusura agli accessori di collegamento
- 2) Inserire le aste negli spacchi predisposti agli angoli dell'anta
- 3) Inserire e fissare il GRATZ all'anta
- 4) Fissare le aste di chiusura al GRATZ con viti M4 in dotazione
- 5) Inserire gli accessori guida aste negli spacchi predisposti e fissati all'anta
- 6) Fissare gli incontri al telaio

- 1) Screw the closing rods to the connection fittings
- 2) Insert the rods into the slits on the leaf corners
- 3) Insert the "GRATZ" mechanism into the leaf and secure
- 4) Secure the closing rods to the "GRATZ" mechanism using the M4 screws
- 5) Insert the rod guides into the slits and fix them to the leaf
- 6) Secure the fittings to the frame

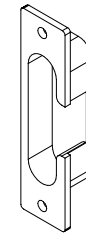
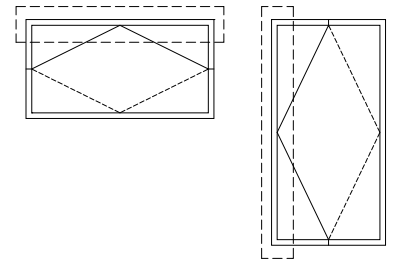

AC2626R incontro 3^ chiusura
OPZIONALE
AC2626R 3rd lock strike plate
OPTIONAL

N.B. prevedere un punto di chiusura ogni 1000 mm max
Attn. Consider one locking point every 1000 mm max

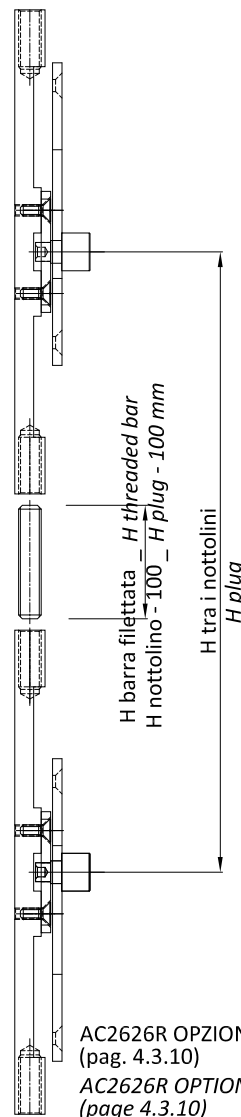

AC2626R OPZIONALE
(pag. 4.3.10)
AC2626R OPTIONAL
(page 4.3.10)

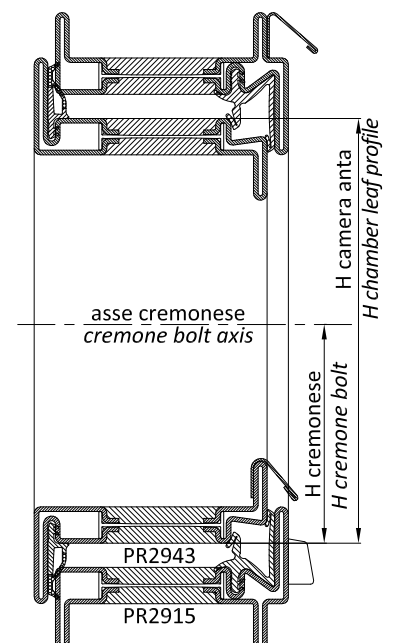

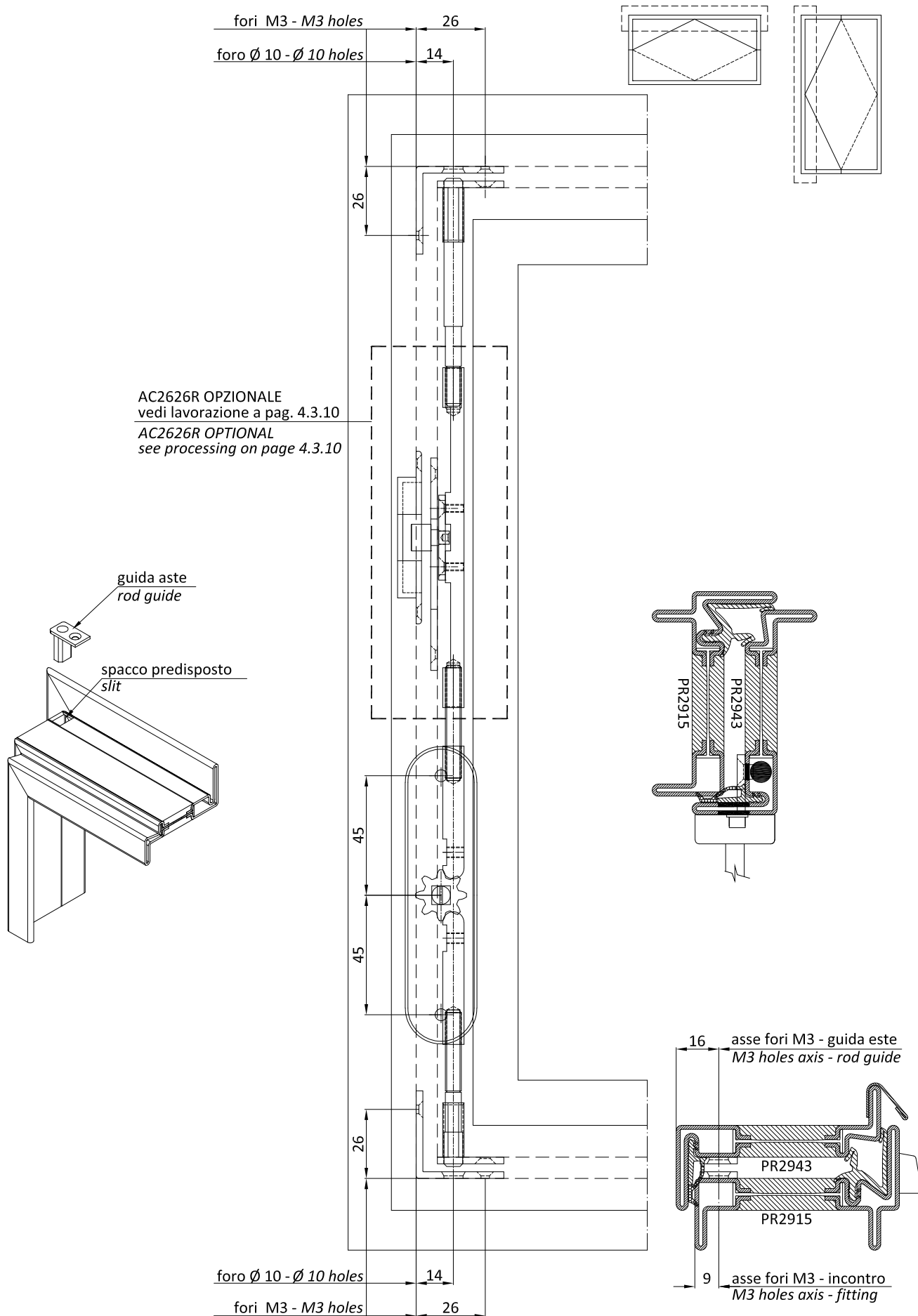

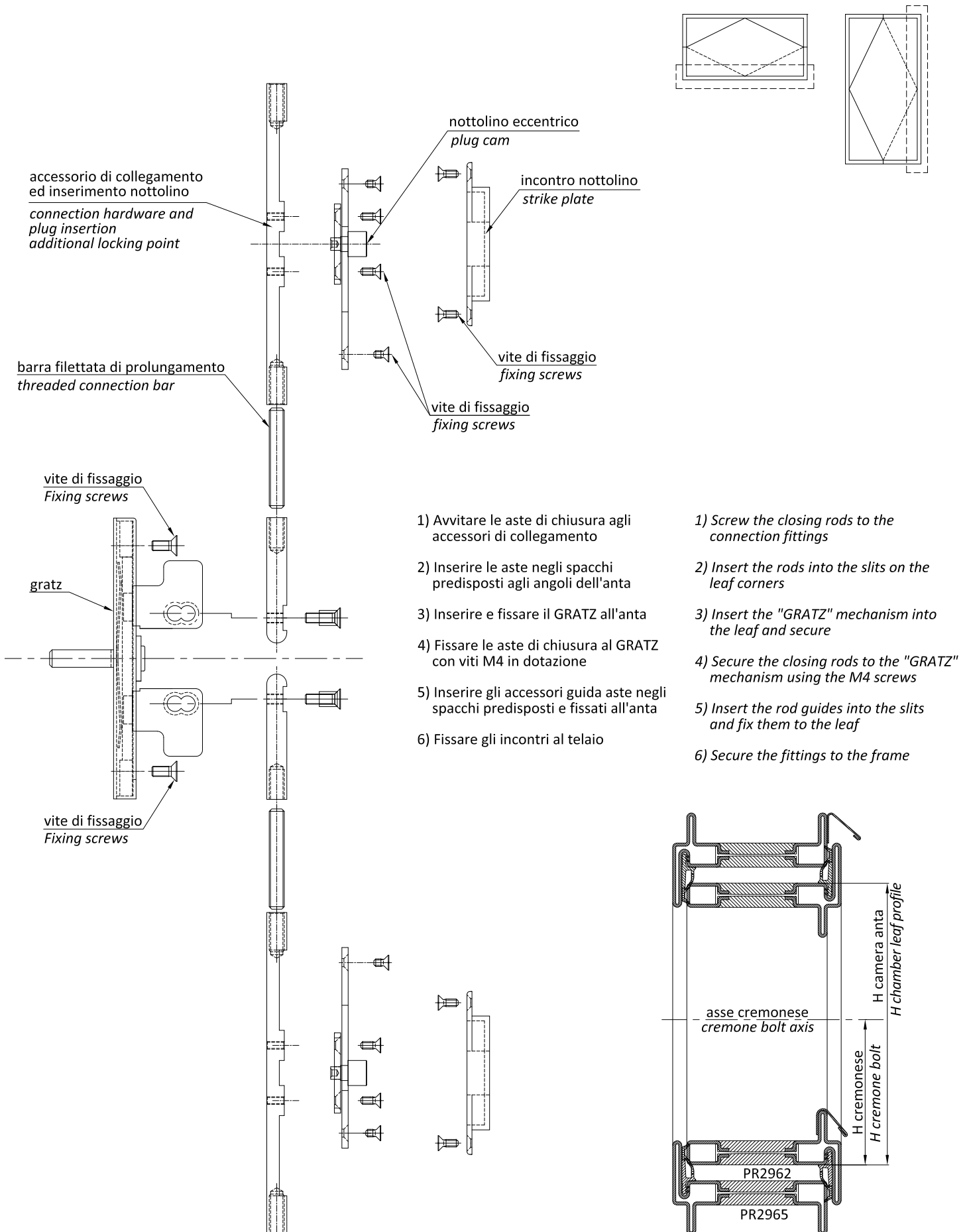

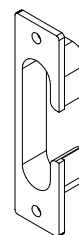
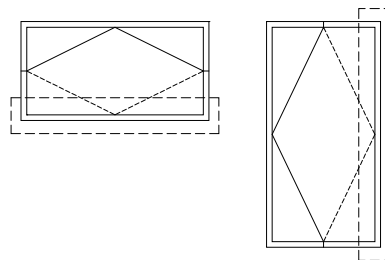

AC2626R incontro 3^a chiusura
OPZIONALE
AC2626R 3rd lock strike plate
OPTIONAL

N.B. prevedere un punto di chiusura
ogni 1000 mm max
Attn. Consider one locking point every
1000 mm max

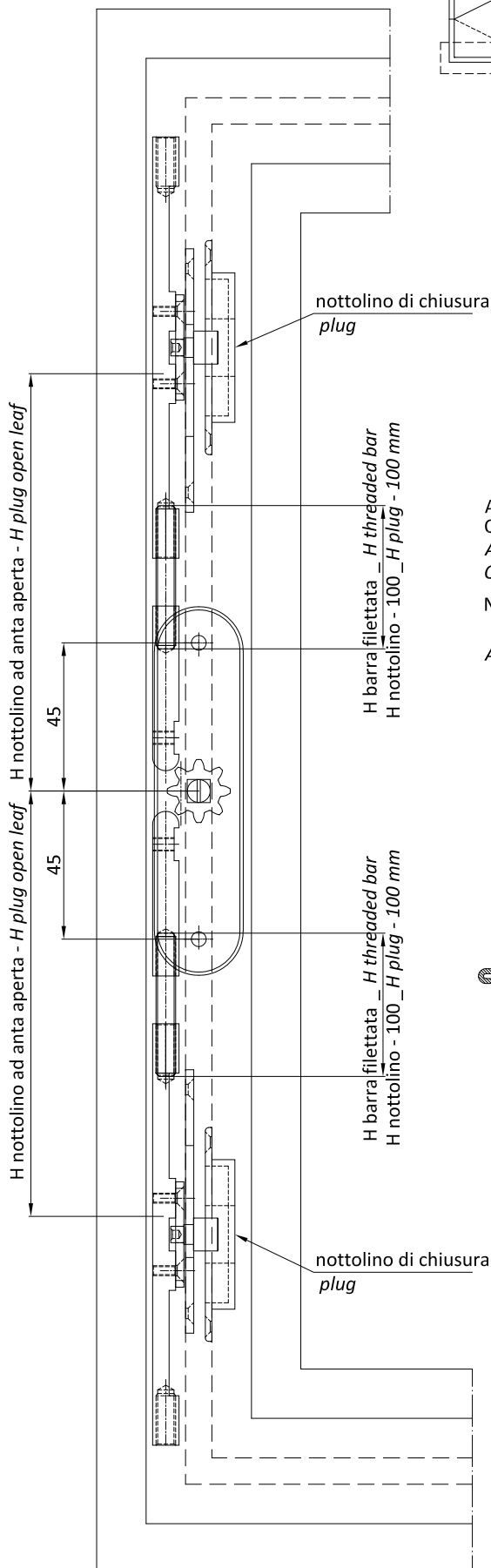
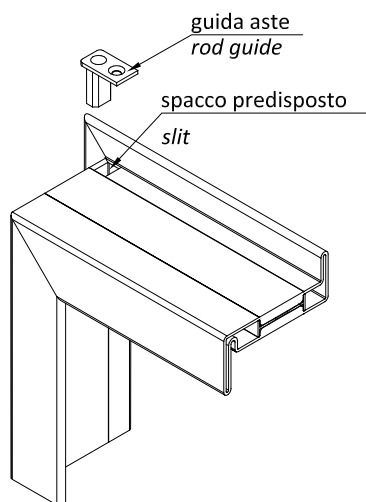
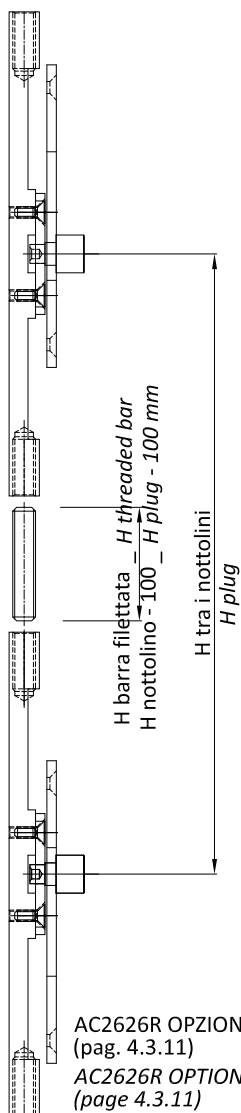
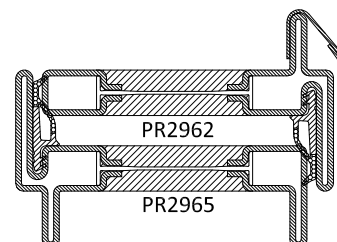
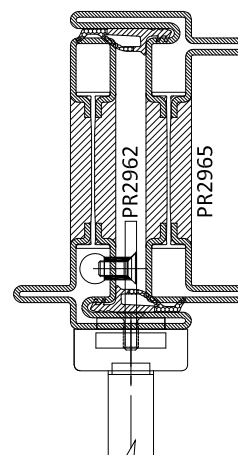

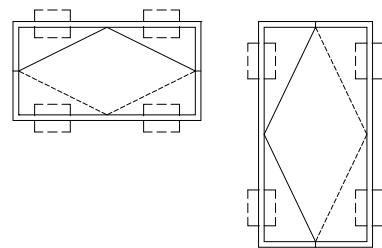
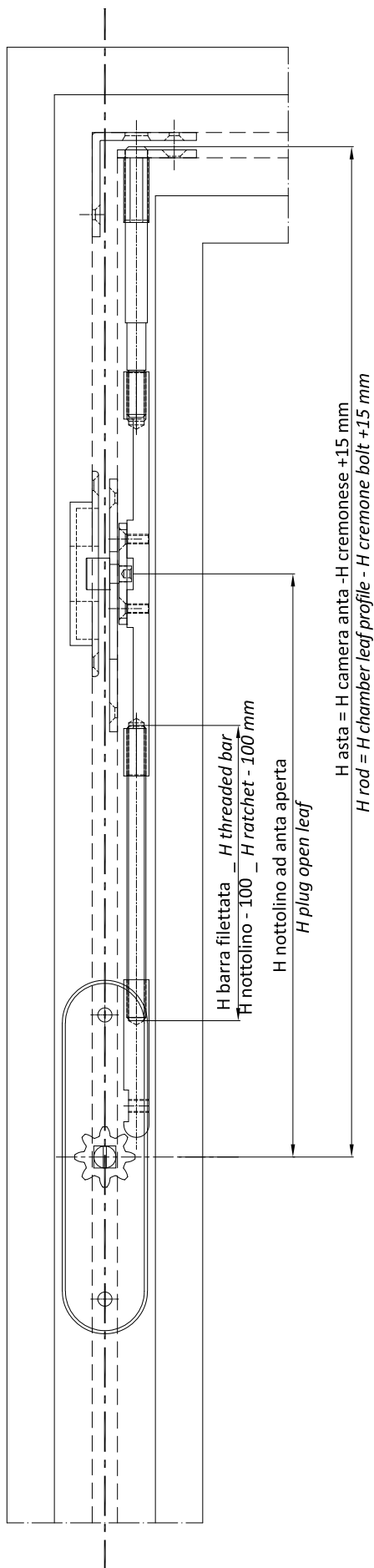

- 1) Rullino eccentrico
- 2) Piastra di fissaggio
- 3) Piastra di collegamento
- 4) Accessorio aggancio aste
- 5) Incontro 3^a chiusura
- 6) viti M3 x 6
- 7) viti M3 x 8

- 1) Barrel cam
- 2) Installation plate
- 3) Connecting plate
- 4) Rod docking accessory
- 5) 3rd lock strike plate
- 6) screws M3 x 6
- 7) screws M3 x 8

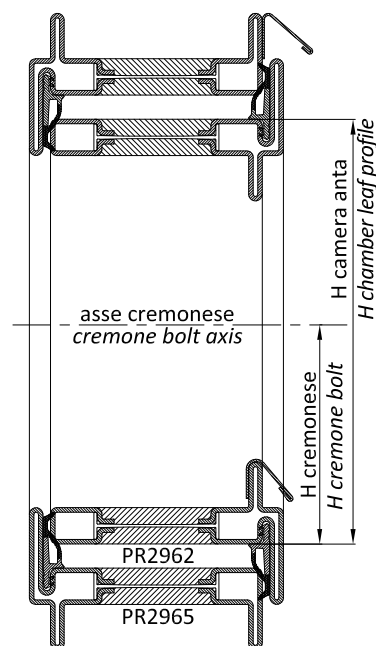
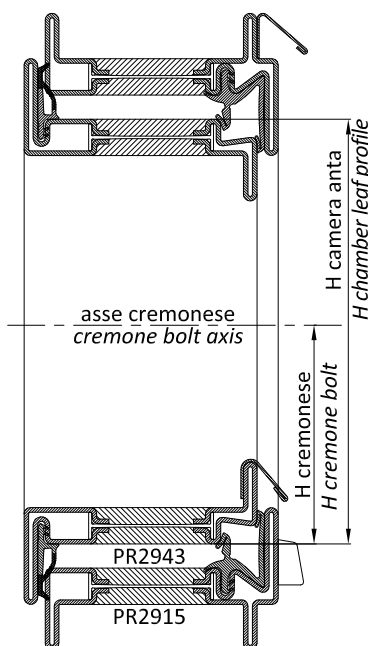
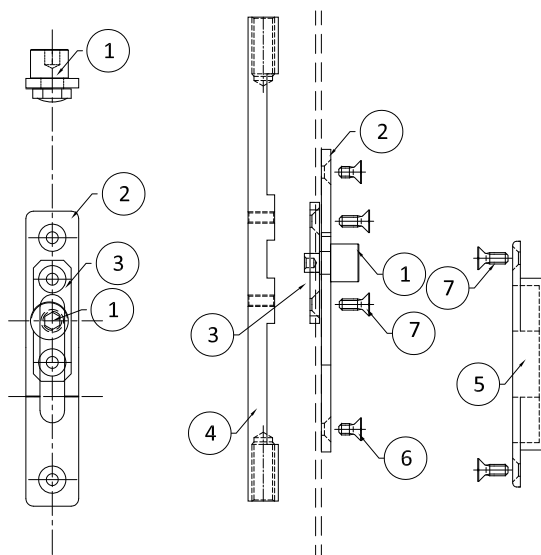

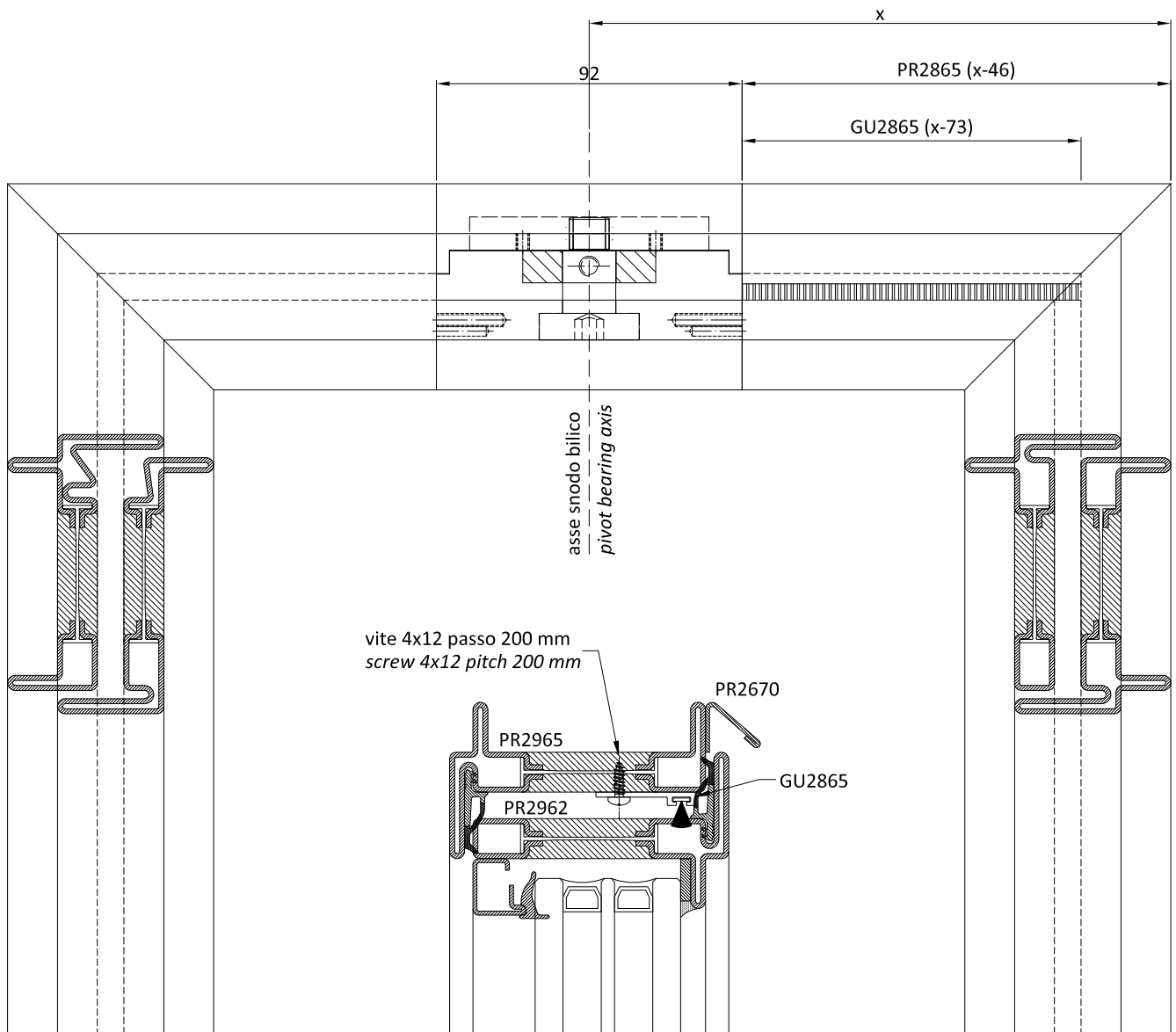
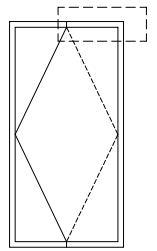

* vite 4x12 mm non comprese | screw 4x12 mm not supplied



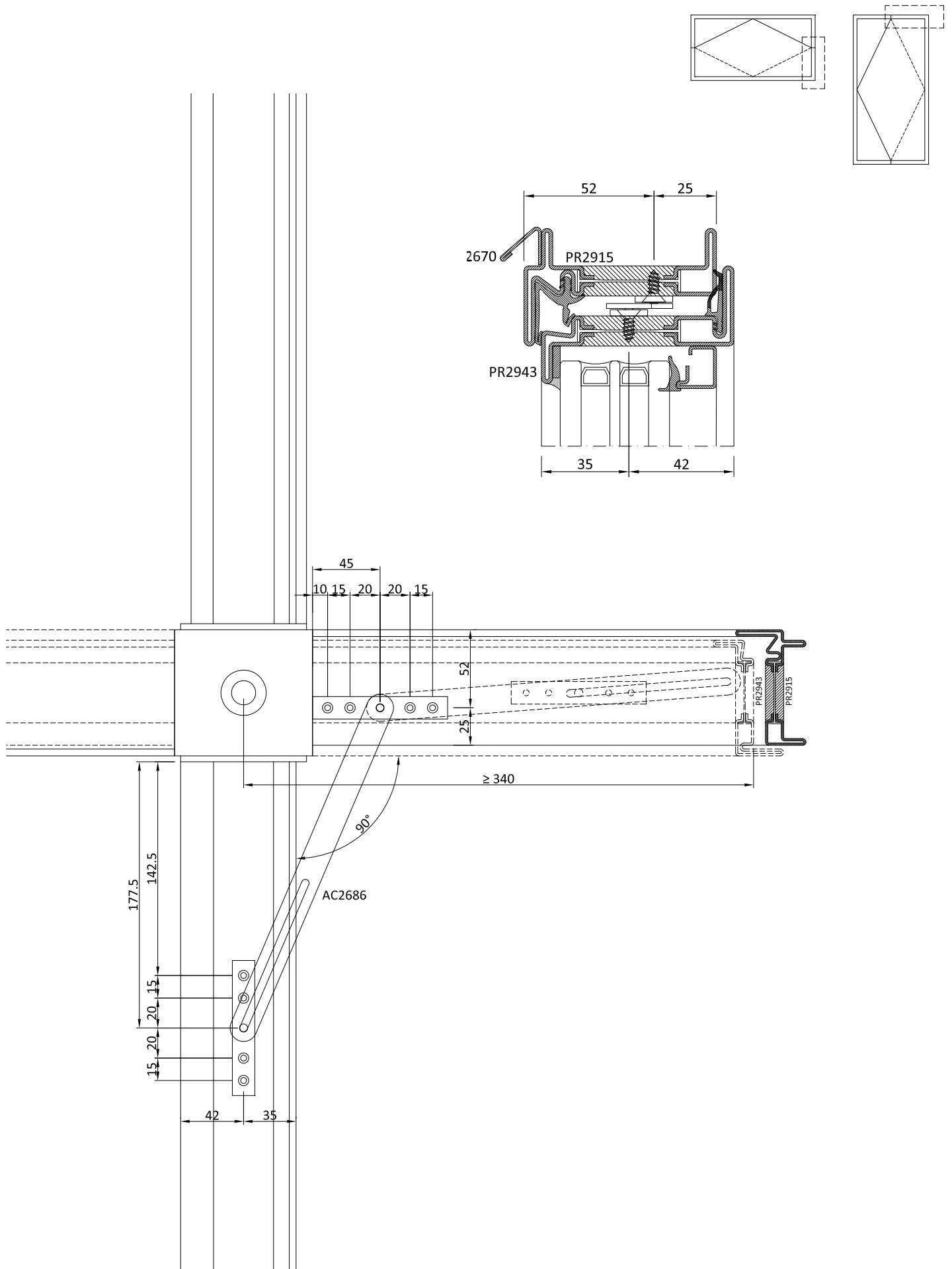

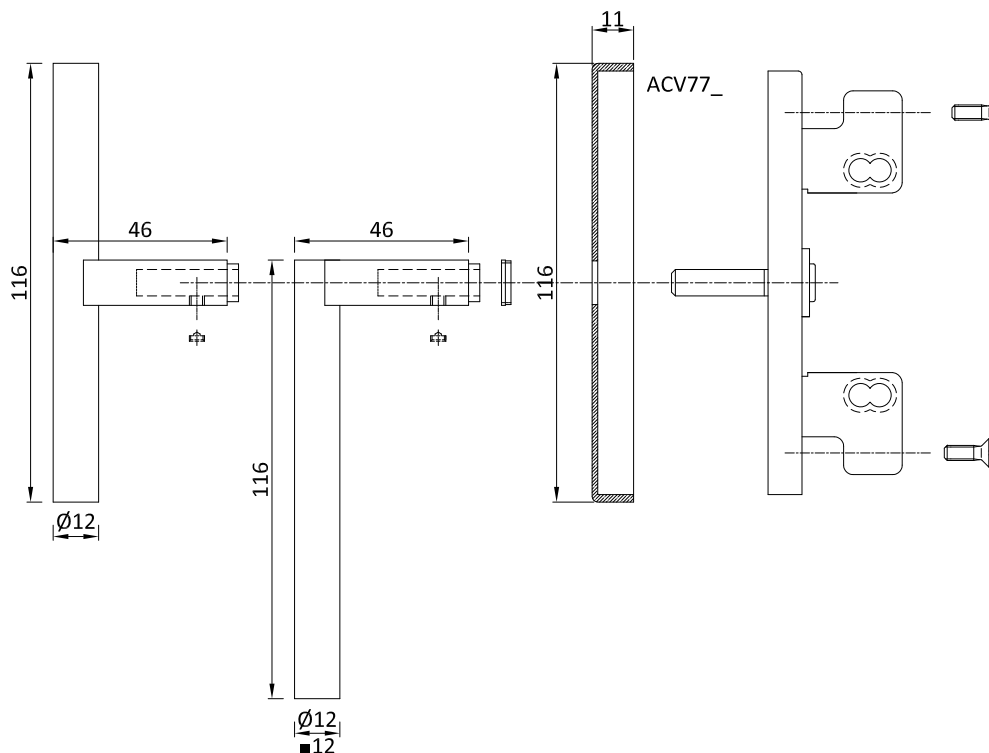
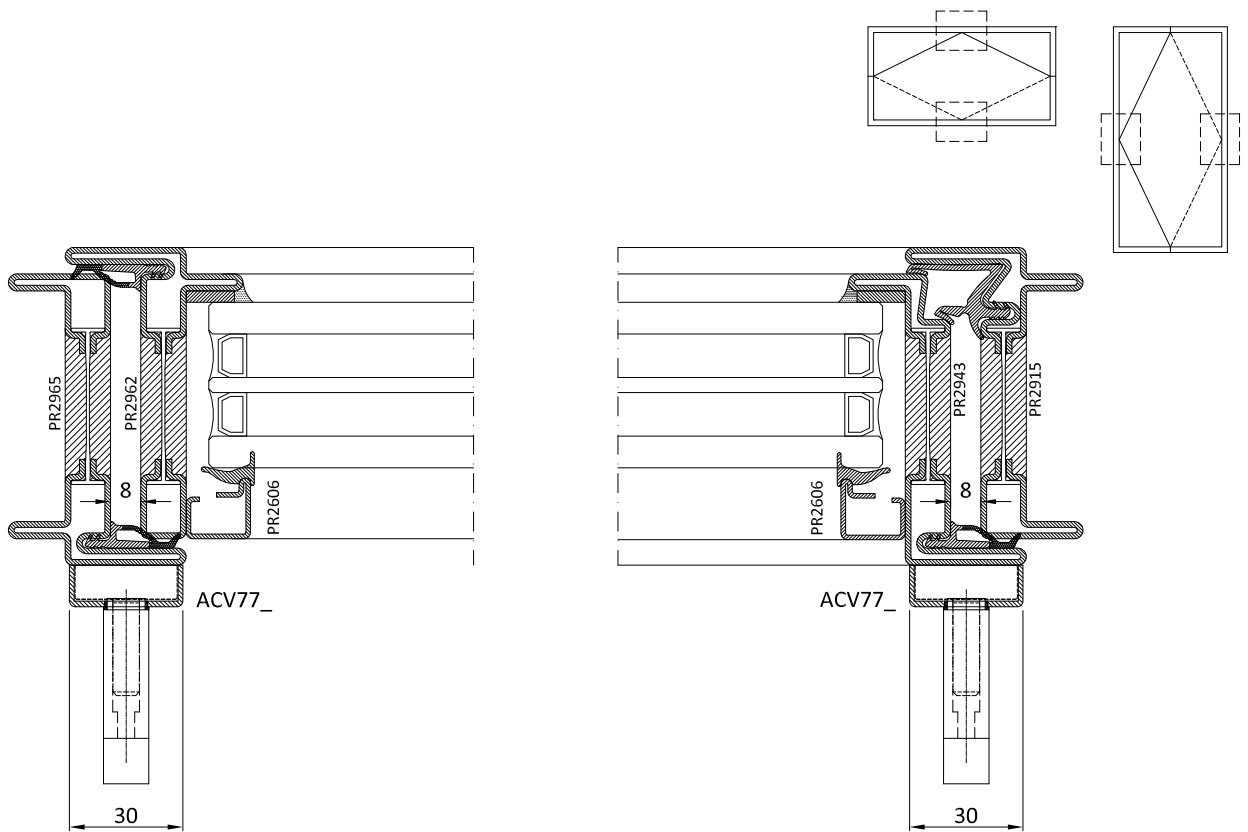

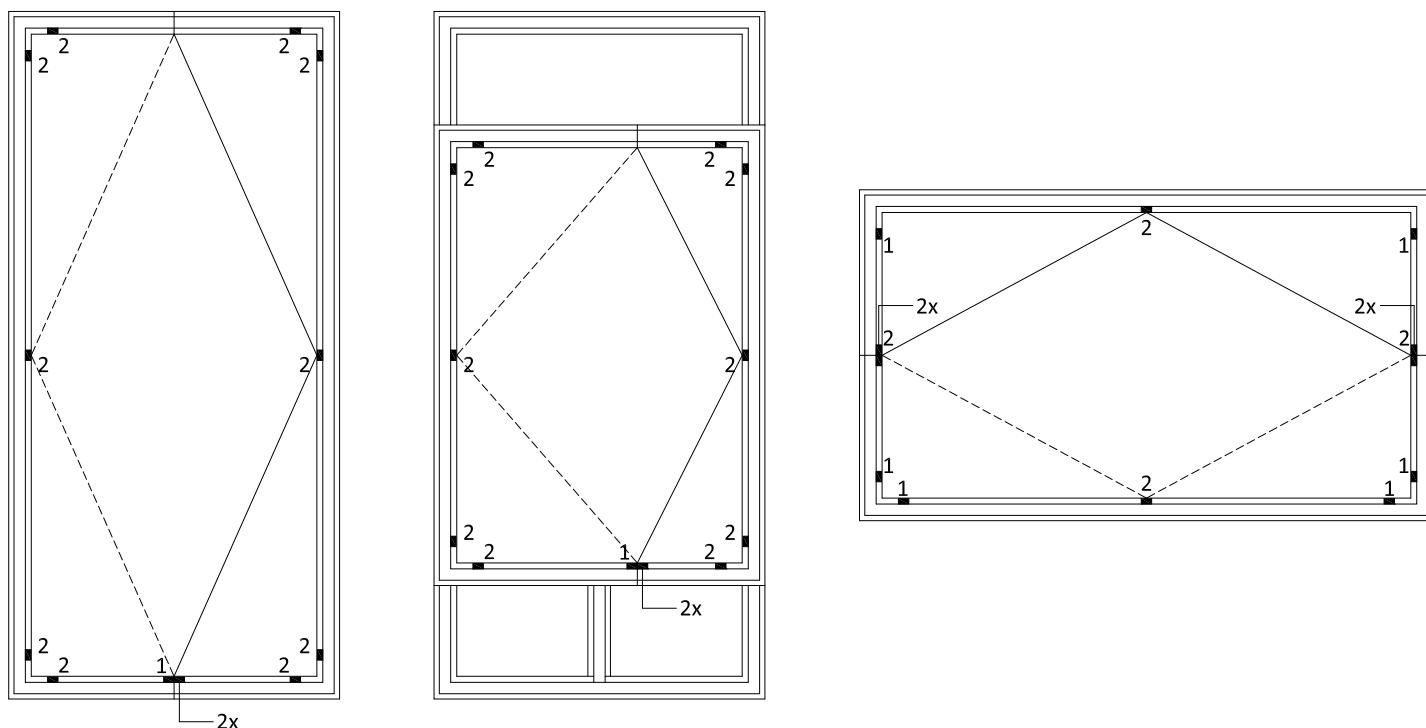

1) spessore portante | *carry shim*

2) spessore distanziatore | *compensation shim*

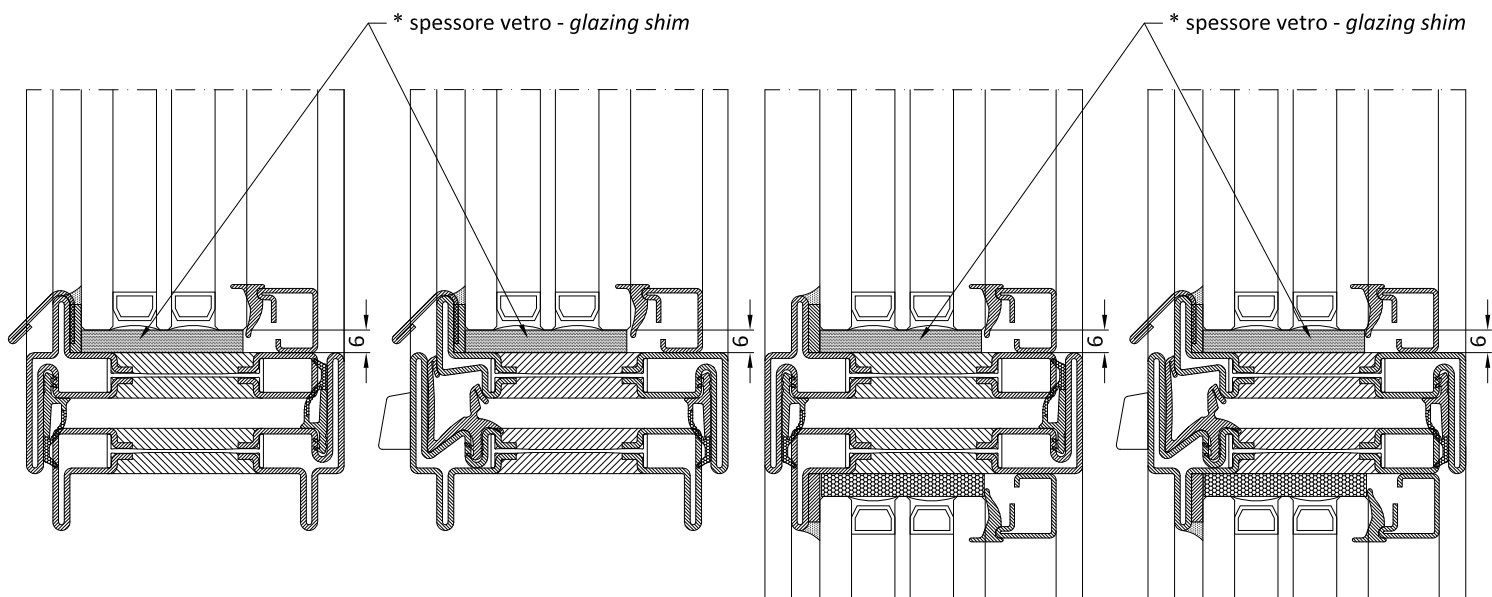

Note / Note

- La larghezza degli spessori è almeno pari o maggiore (+2 mm) dello spessore del vetro installato.
- *The shims width is the same or bigger (+2 mm) than the installed glass spacer.*
- La posizione degli spessori deve essere garantita dall'utilizzo di materiale adeguato che ne eviti la migrazione.
- *The shims position has to be provided by using an appropriate material which avoids any movements.*

* spessori vetro non inclusi - *glazing shims not supplied*

Generalità

I sistemi progettati e sviluppati dalla Secco Sistemi sono idonei per la fabbricazione di un'ampia gamma serramenti, vetrate e facciate in metallo. I sistemi sono rivolti ad aziende esperte e professionali nel campo della lavorazione dei metalli e della costruzione di serramenti e facciate, che sono a conoscenza delle normative di riferimento, delle direttive e delle specifiche tecniche del fornitore del sistema, nonché delle fondamentali regole dell'arte per la produzione e installazione di questi manufatti. Tutta la documentazione tecnica fornita costituisce un riferimento per i tecnici qualificati delle aziende al fine di indicare le modalità per la costruzione dei prodotti. In ogni caso i tecnici qualificati devono analizzare criticamente le indicazioni riportate per verificarne la loro adeguatezza per ogni singola commessa in relazione ai carichi, agli stress previsti e alle condizioni di messa in opera, essendo impossibile riportare in questa documentazione tutte le varianti riscontrabili nei progetti reali.

Tolleranze

OS2 75 è composto da una serie di profili dalle ridottissime dimensioni e prevede un accoppiamento dei telai esterni con le ante apribili con distanza di 8 mm. Per garantire il corretto funzionamento degli accessori e delle guarnizioni le lavorazioni devono essere eseguite con particolare attenzione e precisione: si consiglia di mantenere la tolleranza per la dimensione degli elementi apribili compresa tra +0/-1 mm e la tolleranza per il sormonto degli stessi compresa tra +0/+0.5 mm.

Taglio/Lavorazioni

I profili OS2 75 in acciaio, acciaio inox e corten possono essere tagliati con le normali troncatrici a disco utilizzate per i tubolari in acciaio, mentre per il taglio dei profili in ottone possono anche essere utilizzate troncatrici utilizzate per le serie di alluminio. Vista la loro particolare dimensione e forma si consiglia di utilizzare le ganasce di taglio previste dal sistema (AT2900) per assicurare una perfetta stabilità dei profili durante il taglio. La verifica del taglio sia per la sezione inclinata a 45° che per la sezione verticale a 90° dovrebbe garantire una tolleranza compresa tra -1°/+1°. Tutte le lavorazioni devono essere eseguite con il rispetto della seguente nota tecnica ed eventuali modifiche concordate con l'ufficio tecnico Secco Sistemi.

Saldatura

I profili OS2 75 possono essere saldati con i tradizionali sistemi di saldatura (MIG/MAG, TIG), con un idoneo sistema di lubrificazione/refrigerazione e utilizzando le istruzioni presenti nella presente nota tecnica ed evitando di saldare in prossimità della giunzione a taglio termico. L'eventuale riscaldamento del poliuretano libera sostanze gassose a base di aldeidi e CO: per tale ragione si consiglia di saldare con gli appositi DPI previsti e in zone con sufficiente areazione e in presenza di sistema per l'evacuazione dei fumi. I profili in corten devono essere saldati con apposito filo in corten mentre per i profili in ottone si può utilizzare un filo CuSi3. Si raccomanda di saldare in profondità e senza lasciare fori e porosità le aree in contatto, di lisciare e pulire adeguatamente la superficie saldata per garantire una corretta resistenza strutturale all'angolo e permettere una successiva verniciatura senza imperfezioni estetiche visibili (pori e ondulazioni).

Verniciatura/Brunitura

I profili OS2 75 sono stati progettati per essere verniciati a polveri in forni con temperature di 180°C per 25 minuti. La zona a taglio termico in poliuretano non è in grado di accogliere con sufficiente adesione le polveri poliesteri e perciò si consiglia di ricoprire tali zone, nelle sole parti destinate ad essere in vista, con apposite pellicole adesive idonee al passaggio in forno (SA1024/33/42/52). I telai prima della verniciatura o della brunitura devono essere forati come da istruzioni presenti in questa nota tecnica per permettere la fuoriuscita dei liquidi utilizzati durante il pretrattamento delle superfici. All'uscita del forno di polimerizzazione della polvere i telai vanno rimossi accuratamente e adagiati in posizione piana sino al loro completo raffreddamento. Si consiglia di seguire il ciclo di pretrattamenti e verniciatura presente nella documentazione Secco Sistemi.

Vetrazione

Il sistema di fissaggio del vetro prevede l'utilizzo di fermavetri agganciati all'interno tramite clips o boccole interne e mandati in pressione con l'incastro dell'apposita guarnizione e all'esterno, l'utilizzo di siliconatura o inserimento della guarnizione adesiva GE2606 (il sistema con sigillatura è da utilizzarsi quando le ante superano 1 m² di superficie per garantire una maggior rigidità del pannello vetrato). Per il corretto funzionamento del sistema si suggerisce di verificare la perfetta compressione delle guarnizioni interne del fermavetro e la mancanza di imperfezioni lungo il perimetro della siliconatura esterna.

Installazione

La corretta installazione deve garantire il mantenimento delle performance dichiarate nella marcatura CE e testate in laboratorio. Si consiglia di progettare un corretto numero di fissaggi in relazione al tipo di controtelaio/muratura esistente e alle dimensioni degli elementi da installare. Al termine dell'installazione si verifichi il corretto funzionamento del serramento (facilità di apertura/chiusura, stabilità dell'anta aperta a riposo, etc.), il rispetto delle fughe e del sormonto tra ante apribili e telai fissi, il regolare posizionamento delle guarnizioni e delle sigillature, il drenaggio del giunto aperto e la mancanza di difetti estetici sulle superfici dei telai e del vetro.

General information

The systems designed and developed by Secco Sistemi are suitable for the manufacturing of a wide range of doors, windows and shutters, as well as faces or facades in metal. The systems are designed for professional and expert companies in the metal-working sector and that of construction of doors, windows, shutters and facades. These companies are well aware of the specific regulations and the directions and technical specifications of the system supplier, and also the fundamental rules of the art of manufacturing and installing these products. All the technical documentation provided furnishes a source of reference for the qualified technicians of the companies, giving indications as to how the products should be constructed. These qualified experts must critically analyse the indications to verify their adequacy for each single order in terms of load, stress and conditions of installation, particularly as this documentation cannot provide for all the different variations that may be found in projects.

Tolerance

OS2 75 is made of a series of very thin profiles. It provides coupling of external frames with opening leaves with a distance of 8 mm. To ensure the correct use of hardware and gaskets the processing must be performed with great care and precision. It is advised to keep the tolerance between +0/-1 mm for opening elements and between +0/+0.5 mm for their overlapping area.

Cut / Processing

OS2 75 profiles in steel, stainless steel and corten can be cut with normal saws, like the ones used for steel pipes. OS2 75 profiles in brass can be cut with saws used for aluminium. Given their dimension and size, it is recommended to use the cutting jaws provided with the system (AT2900) to ensure perfect stability during the cutting procedure. In order to verify the correctness of the cut, the tolerance of both the 45° and the 90° sections must be between -1°/+1°. Processing must be performed in line with this technical note and any variation agreed with Secco Sistemi's Technical Department.

Welding

OS2 75 profiles can be welded with the traditional systems (MIG/MAG, TIG), with an appropriate lubricating/cooling system and according to the instructions as per this technical note. Avoid welding near the thermal break joint. Heating any polyurethane items releases gaseous substances containing aldehydes and CO. For this reason it is recommended to weld with the special DPLs provided and in areas with sufficient ventilation and with fumes disposing systems. The corten profiles must be welded with special corten wire, while for profiles in brass a CuSi3 wire can be used. It is recommended to weld in depth, to avoid leaving any holes or porosity on the surfaces and to smooth and clean the welded surface thoroughly. This is to guarantee a proper structural resistance at the corner and to allow for a later painting without any visible imperfections (pores and ripples).

The proper set up must guarantee that the performance in the CE marking and verified in the lab will remain constant. It is advised

Painting/Burnishing

OS2 75 profiles have been designed to be painted with the powder coating technique in industrial ovens at temperatures of 180°C for 25 minutes. The thermal break area is not designed to absorb polyester powders and therefore it's advised to cover the visible areas with appropriate industrial-oven-resistant adhesive films (SA1024/33/42/52). Holes must be drilled (as per instructions) in the frames before painting or burnishing in order to allow drainage of any liquid used as a pre-treatment of the surfaces. Once out of the oven, the frames must be accurately removed and laid in a horizontal position until complete cooling.

It is advised to follow pre-treatment and painting cycles as outlined in Secco Sistemi documentation.

Glass application

Glass needs to be secured internally and externally. Internally, glass beads must be used together with clips or bushings and then secured by pressure with the appropriate gasket. Externally, glass must be secured by applying silicone or adhesive gasket GE2606 (the latter is recommended when leaves dimensions are bigger than 1 square metre in order to guarantee a higher rigidity of the glass). In order to ensure the correct behaviour of the system, it is recommended to verify the proper pressurization of the internal glass bead gaskets and that the external silicone perimeter is completely free of imperfections.

Set up

The proper set up must guarantee that the performance in the CE marking and verified in the lab will remain constant. It is advised to design a correct series of set ups with reference to the existing type of subframe/brickwork and to the dimensions of the elements to set up. Once the set up is finished, you should verify the proper behaviour of the window/door (easiness of opening/closing, stability of the open leaf, etc.), the correctness of joints and overlapping areas between opening leaves and fixed frames, the proper positioning of gaskets and seals, the drainage of frames with weep system and the absence of any aesthetic defects on the frame and glass surfaces.



PR2901

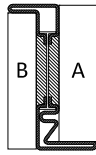

PR2903

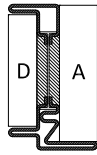

PR2915

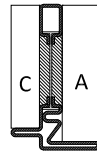

PR2942

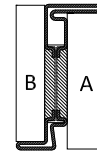

PR2943

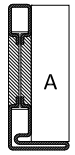

PR2961

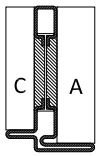

PR2962

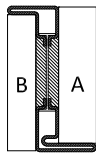

PR2963

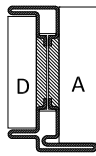

PR2965

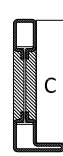

PR2971

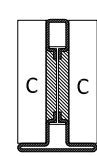

PR2972

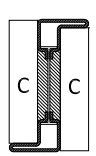

PR2973

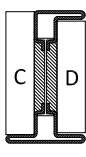

PR2974

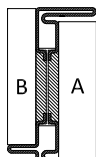

PR2975

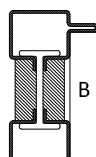

PR2991

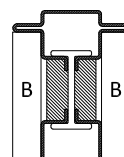

PR2992

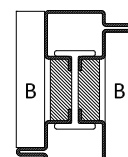

PR2993

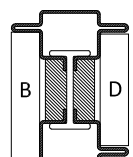

PR2995

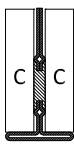

PR2964

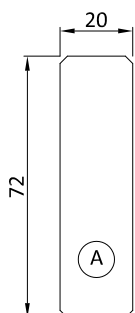

A

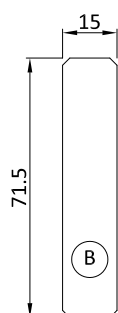

B

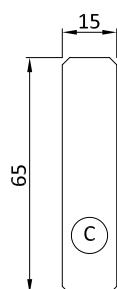

C

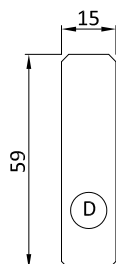

D

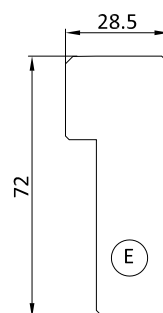

E

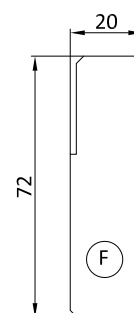

F

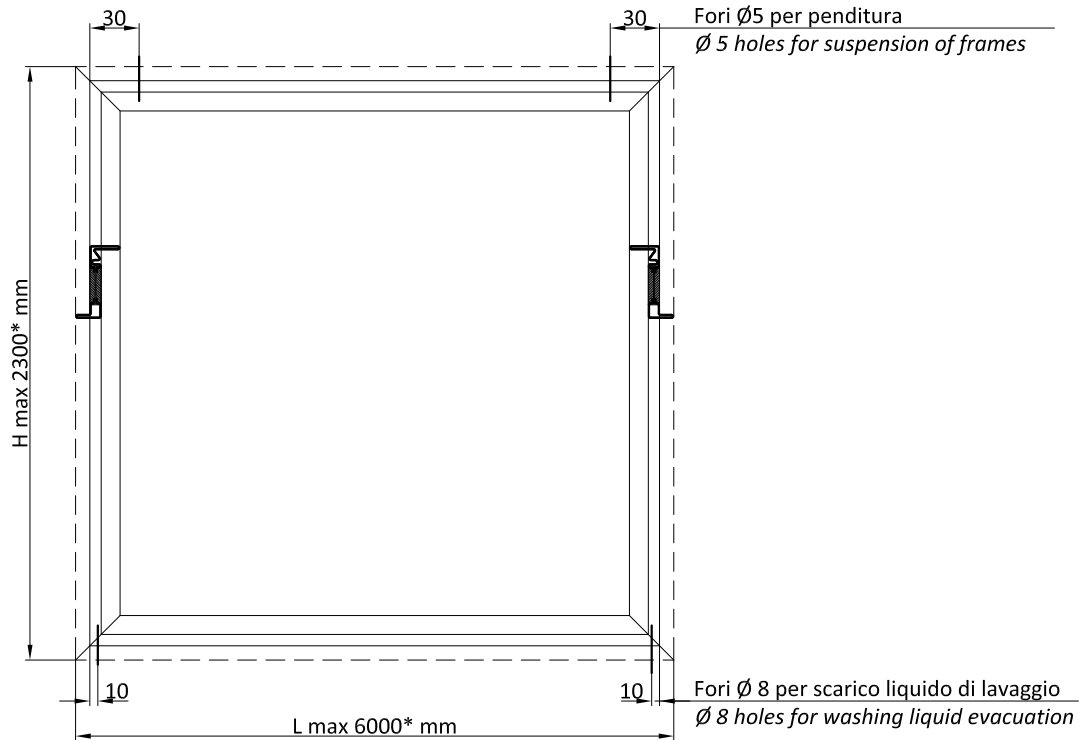

Fori Ø5 per pendinatura
telai con peso inferiore
a 40 kg.

Ø 5 holes for suspension
of frames not heavier
than 40 kg

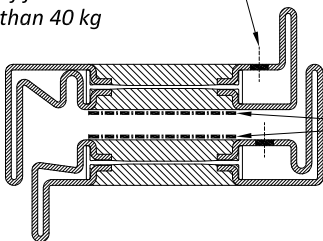

SOLO PER VERNICIATURA
Nastro adesivo protettivo SA1033
resistente alle alte
temperature (220-230°)
ONLY FOR PAINTING
SA1033 protective tape resistant
to high temperatures (220-230°)

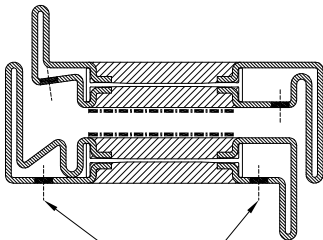

Fori Ø 8 per lo scarico del
liquido di lavaggio
Ø 8 holes for washing
liquid evacuation

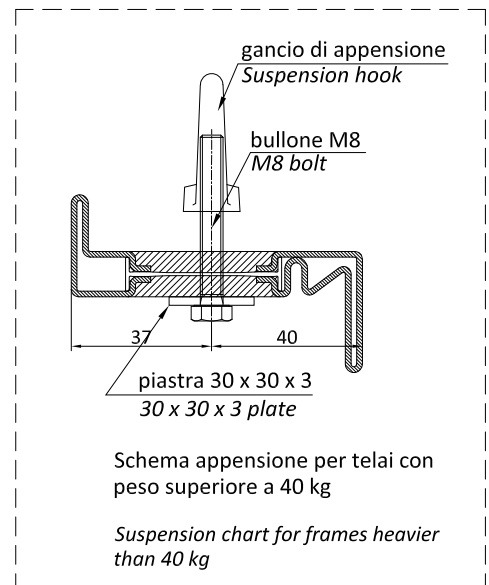

SOLO PER BRUNITURA

Preparare il profilo da trattare pulendolo con una paglietta tipo Scotch Brite in modo da ottenere superfici lucide e uniformi.

Movimentare il prodotto carteggiato con cautela per non danneggiare la finitura superficiale e non toccare a mani nude il profilo per ottenere un trattamento di brunitura uniforme.

ONLY FOR BURNISHING

Prepare the profile grinding it with a Scotch Brite wool in order to obtain uniform surfaces.

Ease profiles carefully to avoid any damages on the surface as well as do not touch it with hands to allow an uniform burnishing.

* Dimensioni massime disponibili nell'impianto di Secco Sistemi
Maximum available size in the Secco Sistemi plant

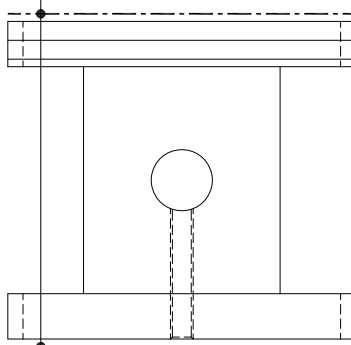
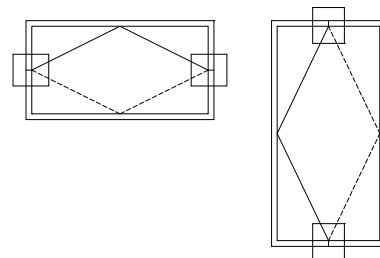
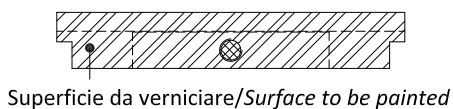

LATO INTERNO
INTERNAL SIDE

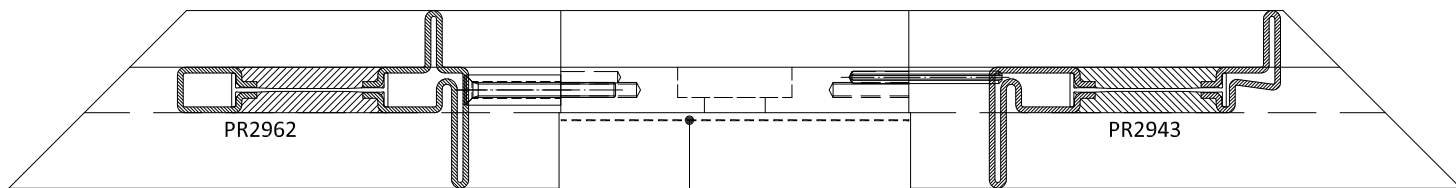

Superficie da proteggere dalla verniciatura
Surface to be protected from painting

cuscinetto da installare
dopo la verniciatura
bearing to be installed
after painting

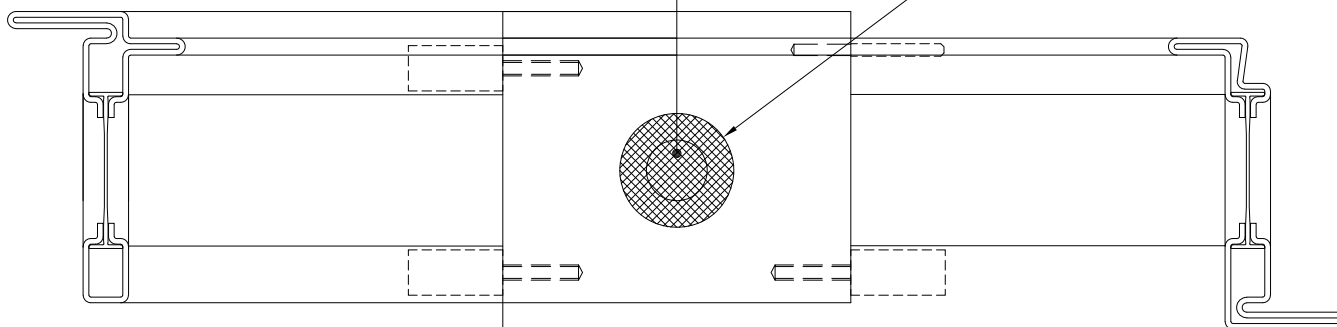

Superficie da proteggere dalla verniciatura
Surface to be protected from painting

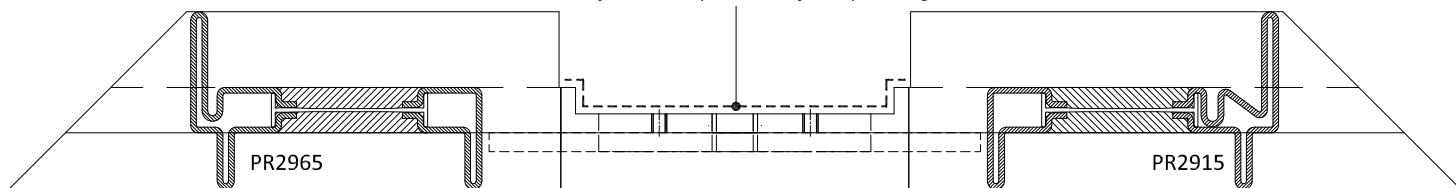

Montata l'intera frizione riempire le zone evidenziate con silicone
After pivot bearing installation fill the highlighted areas with silicone

Superficie da proteggere dalla verniciatura
Surface to be protected from painting

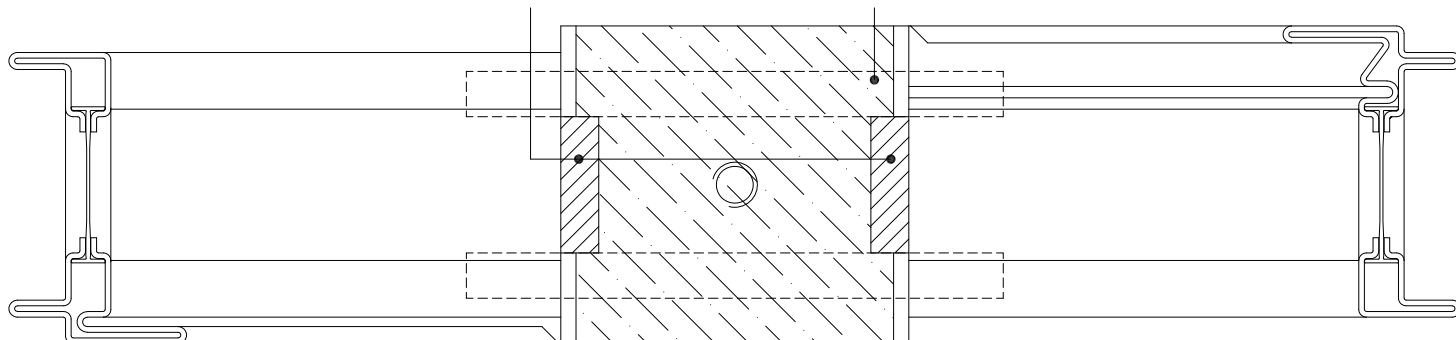

Troncatricecaratteristiche minime della macchina

- Potenza: 1.8 – 2.5 kW;
- Possibilità di taglio a 45° nei due sensi e a 90°;
- Velocità di taglio ideali: 15-30 giri/min per acciaio inox;
60-90 giri/min per acciaio zincato e corten,
90 giri/min o superiori per bronzo (OT/67);
- Capacità di taglio: 150 x 80 mm a 90°;
100 mm taglio a 45°.

caratteristiche della lama

- Lama da 350 mm con spessore 2.5 mm;
- N° denti: - 300 per tagli a 45°;
- 350 per tagli a 90°;
- Materiale: HSS (verificare materiali di commercio con finiture che migliorano la durata delle lame).

NB: è possibile tagliare la lega OT/67 con le stesse macchine dell'alluminio.

Pantografocaratteristiche minime della macchina

- Mandrino con velocità regolabile 2000-11000 giri/min (per un corretta lavorazione su acciaio inox è necessario operare a n° ridotto di giri < 4000);
- Struttura in ghisa adatta al taglio acciaio;
- Testata pesante per limitare le vibrazioni;
- Chiusura del profilo da lavorare con morse.

caratteristiche minime delle frese

- Materiale: HSS (verificare materiali di commercio con finiture che migliorano la durata delle frese);
- Frese a 4 denti;
- Frese con diametro 5 mm per le lavorazioni di scasso.

Foraturemontaggio componenti di chiusura e movimentazione sui profilati in acciaio inox

- Forare con punte da trapano HSS del diametro indicato sulla corrispondente tavola tecnica;
- Maschiare il foro con vite autofilettante zinco-cromata avente diametro corrispondente alla vite inox fornita nel kit con l'articolo da montare;
- Posizionamento e fissaggio definitivo dell'articolo con le viti inox in dotazione.

fresatura di cave e asole sui profili inox

- Adoperare macchine (pantografi o fresatrici) adeguate alle lavorazioni dell'acciaio;
- Regolazione del numero di giri max (3000 giri/1');
- Impiego di frese di diametro massimo di 8 mm a 4 pale in acciaio HSS;
- Abbondare con la lubrificazione, concentrata sull'utensile;
- Ridurre l'avanzamento fino ad accertare un taglio il più regolare possibile;
- È normale un'usura accelerata dell'utensile.

CutterMinimum requirements for the use of the machine

- Power: 1.8 – 2.5 kW;
- Possibility of cutting at 45° in both directions and at 90°;
- Ideal cutting speed: 15-30 rmp for stainless steel;
60-90 rmp for galvanised and corten steel;
90 rmp or higher for bronze (OT/67);
- Cutting capability: 150 x 80 mm at 90°;
100 mm cut at 45°.

Blade specifications

- 350 mm blade with a 2.5 mm thickness;
- Number of teeth: 300 for 45° cut;
350 for 90° cut;
- Material: HSS (please verify availability of longer lasting material on the market).

Note: OT/67 alloy can be cut with machines made for aluminum.

PhantographMinimum requirements for the use of the machine

- Mandrel with a 2000-11000 rmp adjustable speed (for a proper stainless steel processing a slower speed is required i.e.<4000 rpm);
- Machine should be made of cast iron suitable for steel cutting;
- Heavy head in order to limit vibrations;
- Secure the profile to be processed in jaws.

Minimum requirements for the use of a milling machine

- Material: HSS (please verify availability of longer lasting material on the market);
- Use a 4-tooth milling machine;
- Use a milling machine with a 5-mm diameter for groove processing.

DrillingHow to mount closing and moving components on a stainless steel profile

- Use a HSS drill. The diameter of the drill is indicated in the technical note;
- Thread the hole with self-threading zinc-plated screws with the same diameter as the stainless steel screw provided with the kit;
- Position and secure the item with the stainless steel screws provided.

Milling slots and loops in the profiles

- Use machines designed for steel processing (phantographs or milling machines);
- Max rpm setting (3000 rpm);
- Use milling machines with a diameter no bigger than 8 mm and with 4 HSS steel blades;
- Exceed with lubrication, mainly on the machine;
- Processed slowly until the milling is as clean as possible;
- Expect a fast wearing of the machine.

APERTURA A BILICO | PIVOTING WINDOW OPENING

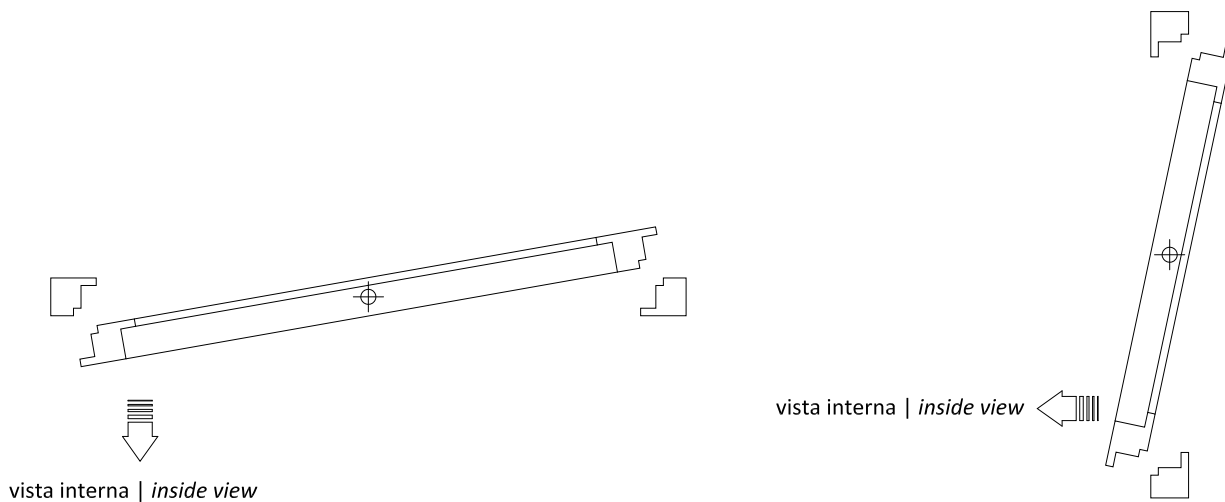

Kit cremonese <i>Cremona bolt</i>	
apertura interna <i>inwards openings</i>	apertura esterna <i>outwards openings</i>
AC 2625 D	AC 2683 S

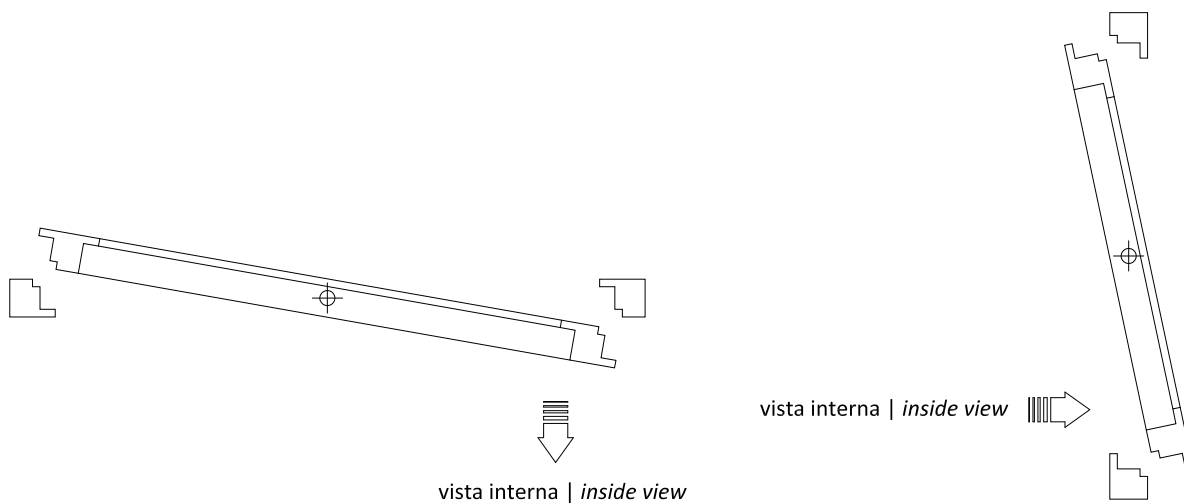

Kit cremonese <i>Cremona bolt</i>	
apertura esterna <i>outwards openings</i>	apertura interna <i>inwards openings</i>
AC 2683 D	AC 2625 S

1. Controllo materiale in arrivo / *Incoming equipment Control*Verifica visiva dell'intergrità delle barre con attenzione a: / *Profiles wholeness visual control paying attention to:*

- Strisci profondi / *Deep scratches* verifica visiva / *visual control*
- Botte e avvallamenti sulla superficie / *Bumps and dips on surface* verifica visiva / *visual control*
- Rettilinearità barre / *Profiles straightness tolerance* 0,002 x L
- Svergolamento / *Profiles twist tolerance* 1° x m

2. Taglio barre e controllo barre / *Cut and Control of profiles*

- Misura lunghezza / *Length measurement* ±0.5 mm
- Verifica 45° / *45° Control* ± 1°
- Verifica 90° / *90° Control* ± 1°

3. Lavorazioni su barra / *Section processing*

Finestra bilico/ Pivoting window	Apertura interna / Inward opening	Apertura esterna / Outward opening
Fori e asole per cremonese <i>Espagnolette holes</i>	AC2625 sez 4.3.7	AC2683 sez 4.3.8-9
Fori e asole per chiusura supplementare <i>Additional locking points slots and holes</i>	AC2626R sez 4.3.10	AC2626R sez 4.3.11
Lavorazione snodo bilico <i>Pivot bearing working</i>	AC2633/37/38 sez 4.3.12-15	AC2633/37/38 sez 4.3.12-15
Fori per scarico acqua <i>Water drip holes</i>	AC2618 sez 4.3.4	
Fori limitatori apertura <i>Restrictor stays holes</i>		AC2687 sez 4.3.42-44
Fresature per limitatori sporgere <i>Stay arm for awning windows milling</i>	-	AC2690 sez 4.3.47
Lavorazione gocciolatoio <i>Water drip section workink</i>	P.2620 sez 4.3.5	P.2670 sez 4.3.6
Fori fissaggio a muro <i>Wall mounting holes</i>	sez 3.3.1-5	sez 3.3.1-5

4. Assiemaggio / *Assembly*

Finestra bilico/ Pivoting window	Apertura interna / Inward opening	Apertura esterna / Outward opening
<u>Costruzione telai</u>		
Inserimento squadrette (profili ottone) – Saldatura / <i>Brackets insertion (brass section) - Welding</i>	AC28xx sez 4.4.1-2	AC28xx sez 4.4.1-2
Sigillatura interna della giunzione (ottone) <i>Internal joint sealing (brass sections)</i>	AC28xx sez 4.4.1-2	AC28xx sez 4.4.1-2
<u>Applicazione accessori</u>		
Assiemaggio snodo bilico <i>Assembling pivot bearing</i>	AC2633/37/38 sez 4.4.6-18	AC2633/37/38 sez 4.4.6-18
Fori limitatori apertura <i>Restrictor stays holes</i>		AC2686 sez 4.5.8

5. Preparazione per verniciatura - brunitura / *Preparation for the powder coating - burnishing*
- a. Fori su telaio per scarichi liquidi pretrattamento sez 5.1.4
Holes on frame for the drainage of pretreatment liquid
 - b. Marcatura e imballo telai esterni e ante -
External frames and leafs branding and packing
 - c. Marcatura e imballo telai fermavetro -
Glazingbeads frames branding and packing
 - d. Marcatura e imballo profili complementari -
Additional profiles branding and packing
 - e. Imballo scarichi acqua e cerniere -
Accessories (water drip, hinges) branding and packing
6. Applicazione accessori e sigillatura / *Hardware and accessories installation and sealing*
- a. Finestra bilico / *Pivoting window*
 - I. Applicazione e sigillatura guarnizioni giunto aperto / sez 4.5.1
Sealing of central gasket
 - II. Applicazione scarichi acqua / *water drip installation* sez 4.5.1
 - III. Montaggio snodo bilico sez 4.4.17-18
Pivot bearing installation
 - IV. Montaggio cremonese e incontri / *Espagnolette installion* sez 4.5.2-7
 - V. Montaggio guarnizioni di battuta / *Gasket installation*
 - VI. Sigillatura angolo nel TT / *Corner joint sealing*
7. Vetrazione / *Glazing*
- a. Applicazione clips fermavetro / *glazing bead clips installation* sez 2.8.1-8
 - b. Applicazione guarnizione esterna / *External glazing gasket installation*
 - c. Applicazione vetro (spessoramento) / *Glazing installation (setting blocks)* sez 4.6.1
 - d. Inserimento fermavetri / *Glazing beads application*
 - e. Inserimento guarnizione interna fermavetro / *Fit glazing bead to glass gasket*
 - f. Verifica corretta compressione guarnizione /
Control of the right compression of the gasket
8. Controlli su prodotto finito / *Control on finished element*
- a. Verifica distanza tra anta e telaio / +0 +0.5 mm
Control of gap between leaf and frame
 - b. Verifica sormonto anta su telaio / *Control of leaf surmount* +0 +1 mm
 - c. Verifica sigillature per scarico acqua / test con acqua su giunto
Control of central gasket sealing test with water
 - d. Verifica funzionamento cremonese/maniglia serratura
Control of hardware functioning
 - e. Verifica finitura superficiale / *Control of surface finishing*
9. Controlli dopo la posa / *Controls after installation*
- a. Verifica corretta installazione telai: squadra, piombo, misure /
Control of alignment and plumbing of frame and leaf
 - b. Verifica distanza tra anta e telaio / +0 +0.5 mm
Control of gap between leaf and frame
 - c. Verifica sormonto anta su telaio / *Control of leaf surmount* +0 +1 mm
 - d. Verifica sigillature per scarico acqua / test con acqua su giunto
Control of central gasket sealing test with water
 - e. Verifica funzionamento cremonese/maniglia serratura
Control of hardware functioning
 - f. Verifica finitura superficiale / *Control of surface finishing*

MATERIALI**ACCIAIO INOX****Materiale**

Profilati ricavati da nastro di lamiera di acciaio inox laminato a freddo pre-trattato industrialmente per garantire la massima qualità e uniformità.

Caratteristiche fisiche

AISI 316L Marino (X2 CrNiMo 17-12-2)

Norme di riferimento

EN 10088-2; EU 114

Trattamenti superficiali

Finitura Scotch Brite: ottenuta su nastro AISI 316L (marino) con finitura superficiale 2B con successiva spazzolatura Scotch Brite.

ACCIAIO COR-TEN**Materiale**

Profilati ottenuti da nastro in acciaio altoresistenziale, autopassivante (che un tempo veniva commercializzato con il nome Cor-Ten) tale da formare, se esposto all'aria, uno strato di ossido uniforme e stabile che, ricoprendo la lamiera, ne arresta la corrosione atmosferica.

Caratteristiche fisiche

Fe 510 X (C max % 0,12; Si % 0,25-0,75; Mn % 0,20-0,50; P % 0,07-0,15; Cu % 0,25-0,55; Cr % 0,30-1,25; Ni max % 0,65)

Norme di riferimento

EN 10149

Trattamenti superficiali

Dopo la profilatura il materiale viene immerso in speciali bagni ossidanti tali da accelerare la formazione dello strato protettivo. Raggiunta la tonalità desiderata della superficie si procede ad una ceratura di stabilizzazione del materiale.

ACCIAIO ZINCATO VERNICIATO**Materiale**

Profilati ottenuti da nastro in lamiera di acciaio zincato a caldo sistema Sendzimir finitura skinpassata

Caratteristiche fisiche

FeP02 GZ 200 (copertura di zinco pari a 200gr/m² per faccia)

Norme di riferimento

UNI EN 10142/3/7; EURONORM 143

Trattamenti superficiali per la verniciatura

La preparazione del supporto zincato si effettua tramite i processi di sgrassaggio, decapaggio e lavaggio in acqua. Segue l'applicazione di uno strato di zinco per fosfatazione seguito da lavaggi in acqua demineralizzata. Infine applicazione della mano a finire con polveri poliestere cotte in forno a 180 °C per 25 minuti.

LEGA DI RAME OT67**Materiale**

Profilati ottenuti da nastro di Lega di Rame OT67 laminato a freddo rincrudito allo stato grezzo.

Caratteristiche fisiche

Cu Zn 33 CW 506L (OT 67, 67% rame e 33% zinco)

Norme di riferimento

EN 1652:1999

Trattamenti superficiali

Finitura brunita: dopo la profilatura viene eseguita una ricottura di distensione, quindi la pulitura meccanica con abrasivo e la successiva brunitura per immersione con liquido brunitore; il profilo viene poi lavato e asciugato ed infine protetto mediante trattamento con olio di vaselina.

Finitura lucida: dopo la profilatura viene eseguita una ricottura di distensione e successivamente la lucidatura a specchio.

MATERIALS**STAINLESS STEEL****Materials**

Sections processed out of the cold-rolled coils, industrially pre-treated for utmost quality and uniformity.

Physical features

AISI 316L Marino (X2 CrNiMo 17-12-2)

Norms of reference

EN 10088-2; EU 114

Surface treatment

Scotch Brite: obtained on AISI 316L (marine) coil 2B pre-finish with Scotch-Brite post-scrubbing.

CORTEN STEEL**Materials**

Sections processed out of highly resistant self-oxidising steel coils – once traded under the name Cor-Ten. If exposed to the open air, it produces a uniform protective layer that reduces weather corrosion.

Physical features

Fe 510 X (C max % 0,12; Si % 0,25-0,75; Mn % 0,20-0,50; P % 0,07-0,15; Cu % 0,25-0,55; Cr % 0,30-1,25; Ni max % 0,65)

Norms of reference

EN 10149

Surface treatment

After forming, sections are plunged into a special oxydising bath to catalyze formation of the protective coating. Once the desired tone obtained, sections are stabilized by a wax coating.

GALVANIZED AND PAINTED STEEL**Materials**

Sections processed out of hot galvanized steel coils, band "Sendzimir, skinpassed finishing.

Physical features

FeP02 GZ 200 (with zinc coating of 200 gr/sq x m on both faces)

Norms of reference

UNI EN 10142/3/7; EURONORM 143

Pre-painted surface treatment

The preparation of a galvanised surface is made through several processes: degreasing, pickling and washing. A coating of zinc is then applied through a phosphatising process followed by rinses in demineralised water. A final coat is then applied with polyester powders baked at 180 °C for 25 minutes.

COPPER ALLOY OT67**Materials**

Sections processed out of copper alloy coils, industrially cold-rolled.

Physical features

Cu Zn 33 CW 506L (OT 67, 67% copper and 33% zinc)

Norms of reference

EN 1652:1999

Surface treatment

Burnished finish: after forming, the product is submitted to stress relieving, then to mechanical cleaning with abrasive products and ultimately to burnishing by plunging into a burnishing solution. It is then washed and dried and protected with a vaseline coating.

Glossy finish: after forming, the product is submitted to stress relieving and then mirror-like polished.

INDICE ANALITICO | SUBJECT INDEX

AC2608	2.8.1-3 2.8.6
AC2609	2.8.3 2.8.6
AC2617N	4.5.1
AC2618	4.3.4 4.5.1
AC2618NE	4.3.4 4.5.1
AC2625D	4.2.3-4 4.3.1 4.3.7 4.5.2-3
AC2625S	4.2.3-4 4.3.1 4.3.7 4.5.2-3
AC2625ED	4.2.3-4 4.3.1 4.3.7 4.5.2-3
AC2625ES	4.2.3-4 4.3.1 4.3.7 4.5.2-3
AC2626R	4.2.3-4 4.3.10-11 4.5.6
AC2533H	4.2.3-4 4.3.12-14 4.4.6-7 5.1.5
AC2533V	4.2.3-4 4.3.12-14 4.4.6-7 5.1.5
AC2533SH	4.2.3-4 4.3.12-13 4.3.15 4.4.8-9 5.1.5
AC2533SV	4.2.3-4 4.3.12-13 4.3.15 4.4.8-9 5.1.5
AC2637H	4.2.3-4 4.3.12-14 4.4.10-11 5.1.5
AC2637V	4.2.3-4 4.3.12-14 4.4.10-11 5.1.5
AC2638H	4.2.3-4 4.3.12-14 4.4.12-13 5.1.5
AC2638V	4.2.3-4 4.3.12-14 4.4.12-13 5.1.5
AC2658	4.3.2
AC2659	4.3.3
AC2683D	4.2.3-4 4.3.1 4.3.8-9 4.5.4-5
AC2683S	4.2.3-4 4.3.1 4.3.8-9 4.5.4-5
AC2683ED	4.2.3-4 4.3.1 4.3.8-9 4.5.4-5
AC2683ES	4.2.3-4 4.3.1 4.3.8-9 4.5.4-5
AC2686	4.5.8
AC2801I	4.4.1-2
AC2803I	4.4.1-2
AC2843I	4.4.1-2
AC2853I	4.4.1-2
AC2855I	4.4.1-2
AC2862I	4.4.1-2
AC2865I	4.4.1-2
AC2871I	4.4.1-2
AC2872I	4.4.1-2
AC2875I	4.4.1-2
AC2891I	4.4.1-2
AC2892I	4.4.1-2
AC2895I	4.4.1-2
ACB219.BR	4.3.4 4.5.1
ACV771	4.5.9
ACV772	4.5.9
ACV773	4.5.9
ACV774	4.5.9
ACV776	4.5.9
ACV777	4.5.9
ACV779	4.5.9
AT2800	5.1.3
CV1023	2.8.4 2.8.6
CV1243	2.8.4-7
CV5012	2.8.4-7
PR2620	4.3.5
PR2670	4.3.6
GU2865	4.5.7

METALFORM

MASTERS OF METAL

UNITED KINGDOM

METALFORM

NORWAYMETAL LTD

53 Chelsea Manor Street

London, SW3 5RZ

SALES@METALFORM.UK

+44 20 81298814

GERMANY

METALFORM GMBH

Carl-Zeiss-Ring 15A

85737 Ismaning

SALES@METALFORMGROUP.DE

+49 17663630406

NORWAY

METALFORM AS

Brochmannsveien 2

1950 Rømskog

SALG@METALFORM.NO

+47 401 62 446

METALFORMGROUP

SALES@METALFORMGROUP.COM