

**EBE 65**  
CATALOGO  
TECNICO  
TECHNICAL  
CATALOGUE

**METALFORM**

The logo for Secco, featuring the word "secco" in white lowercase letters on a red trapezoidal background that tapers to the right.

**secco**







<b>1</b>	<b>Informazioni generali / General informations</b>	
	Descrizione del sistema / System description .....	1.1.1
	Tipologie e limiti dimensionali / Typologies and dimensional limits .....	1.2.1 – 1.2.3
<b>2</b>	<b>Componenti del sistema / System component</b>	
	Profili / Profiles .....	2.1.1 – 2.1.4
	Accessori / Accessories .....	2.2.1 – 2.2.6
	Ferramenta / Hardware .....	2.3.1 – 2.3.12
	Squadrette / Corner joint .....	2.4.1 – 2.4.4
	Maniglie / Handles .....	2.5.1 – 2.5.3
	Guarnizioni / Gaskets .....	2.6.1 – 2.6.3
	Attrezzature / Working tools .....	2.7.1 – 2.7.3
	Prodotti / Products .....	2.8.1 – 2.8.2
	Fermavetri / Glazing beads .....	2.9.1 – 2.9.12
	Dividivetro / Glazing beads .....	2.10.1 – 2.10.2
<b>3</b>	<b>Tecnica del sistema / System technique</b>	
	Sezioni porte / Doors sections .....	3.1.1 – 3.1.11
	Sezioni finestre / Windows sections .....	3.2.1 – 3.2.7
	Attacchi alla muratura / Attachment to structure .....	3.3.1 – 3.3.5
<b>4</b>	<b>Lavorazioni e ciclo produttivo / Processing plan</b>	
	Distinte di taglio / Cutting list .....	4.1.1 – 4.1.17
	Assiemaggio / Assembly .....	4.2.1 – 4.2.24
	Lavorazione e applicazione accessori porte / Working and installation of door accessories .....	4.3.1 – 4.3.37
	Lavorazione e applicazione accessori finestre / Working and installation of window accessories .....	4.4.1 – 4.4.72
<b>5</b>	<b>Note generali sul processo / Processing general informations</b>	
	Raccomandazioni per la lavorazione / Working recommendations .....	5.1.1 – 5.1.6
	Taglio, asolature, forature / Cutting, slots, holes .....	5.2.1 – 5.2.2
	Verifica qualità / Quality audit cycle .....	5.3.1
	Caratteristiche materiali / Materials characteristic .....	5.4.1 – 5.4.2
	Indice analitico / Subject index .....	5.5.1 – 5.5.2

**Sistema integrato di profili, accessori e guarnizioni a taglio termico** con profili aventi sezione di 65 mm e/o 73.5 mm, idoneo per la realizzazione di porte e finestre, rettangolari, sagomate o curve con o senza fissi laterali e superiori.

**I profili in metallo** componenti il sistema sono dello spessore di 15/10 mm e sono ottenuti tramite profilatura a freddo di nastri nei vari materiali previsti dal sistema.

**Il taglio termico dei profili** è realizzato tramite un estruso in poliammide rinforzato con fibra di vetro reso solidale alle parti in metallo esterne da una resina poliuretanicca ad alta densità, iniettata ad alta pressione. Il collegamento che si ottiene è continuo, privo di interruzioni e garantisce la massima resistenza torsionale e flettente.

**La costruzione dei telai** prevede l'unione tra i profili tramite saldatura in continuo delle sezioni in contatto e la successiva ripresa delle superfici in vista, o l'utilizzo di un sistema misto ad assiemaggio meccanico a saldatura interna che non necessita di riprese di finitura.

Il sistema prevede al possibilità di alloggiare vetri singoli o stratificati (di sicurezza) a una o più camere.

#### Sistema porte:

Complanarità delle ante;

Doppia guarnizione di tenuta per elevate caratteristiche prestazionali e acustiche;

Completa dotazione di accessori negli stessi materiali del profilo;

Cerniere a saldare, avvitare e a scomparsa per grandi portate;

Maniglie con diverse soluzioni estetiche;

Paraspifferi inferiore con guarnizione a pinna.

#### Sistema finestre:

Complanarità esterna e sormonto interno delle ante;

Sistema di guarnizioni a giunto aperto per le massime prestazioni di resistenza all'aria, acqua e vento ed elevati valori di resistenza acustica;

Idonea camera porta-accessori per l'alloggiamento di ferramenta certificata e per la riduzione dei tempi di lavorazione;

Sistema integrato completo di accessori per lo scarico acqua;

Completa dotazione di accessori:

Ferramenta per apertura ad anta, anta ribalta, vasistas per serramenti rettangolari, trapezoidali e curvi fino a 150 kg;

Ferramenta per cerniere a scomparsa.

**Integrated system of thermally broken profiles, hardware and gaskets with 65 mm and 73.5 mm sections, suitable for rectangular, profiled or arched doors and windows, with or without sidelights and upper lights.**

**The metal profiles** that make up the system are 15/10 mm thick and are obtained from the cold-forming of the coils in the various materials available.

**The thermal break** of the profiles is realized with an extruded polyamide reinforced with fibre-glass that is collocated flush with the external parts in metal by means of a high-density polyurethane resin injected at high pressure. The result is a seamless connection without interruptions which guarantees maximum resistance to torsional and bending stress.

**For frame assembly the profiles** must be joined by welding the sections in contact with each other, or by mechanically assembling and then internally welding which does not need finishing touches. Double or triple thermally insulated glazing may be used with single or stratified (safety) glass.

#### Doors system:

coplanarity of the doors;

double sealing gasket for high performance and acoustics;

complete with accessories in same material as profile;

hinges to be welded, screwed or concealed for large capacities;

selection of handles with different aesthetic solutions;

lower seal with fin.

#### Windows system:

external coplanarity and internal overlap of the leaves;

system of open joint gaskets for maximum resistance to air, water and wind, as well as high levels of acoustic resistance;

hardware container to keep all certified hardware and reduce time required for tooling;

integrated system complete with accessories for drainage of water; all accessories furnished;

hardware for side hung opening, tilt and turn, bottom-hung windows for rectangular, trapezoidal and arched fixtures up to 150 kg. hardware for concealed hinge

### PRESTAZIONI

#### Sistema finestre

Trasmittanza termica (UNI EN 10077-2)

-Nodo tipo (acciaio inox) con  $U_f=2,7 \text{ W/m}^2\text{K}$

-Finestra tipo (1230x1480 mm con  $U_g1,0$ )  $U_w=1,5 \text{ W/m}^2\text{K}$

Isolamento acustico (UNI EN 717-1)

-Fino a 47 dB

Resistenza all'aria (UNI EN 12207)

-Classe 4

Resistenza all'acqua (UNI EN 12208)

-Classe 9A

Resistenza al vento (UNI EN 12210)

-Classe C5

Resistenza alla forza di azionamento (UNI EN 13115)

-Classe 1 – < 100 N

Prova carico verticale e torsione statica (UNI EN 13115)

-Classe 4 – 800 N / 350 N

Prova di durata a cicli di apertura (UNI EN 12400)

-Classe 2 - 10.000 cicli

### PERFORMANCES

#### Windows system

Thermal transmittance (UNI EN 10077-2)

-Typical section (stainless steel) with  $U_f=2,7 \text{ W/m}^2\text{K}$

-Typical window (1230x1480 mm with  $U_g1,0$ )  $U_w=1,5 \text{ W/m}^2\text{K}$

Acoustic insulation (UNI EN 717-1)

-Up to 47 dB

Air resistance (UNI EN 12207)

-Class 4

Watertightness (UNI EN 12208)

-Class 9A

Resistance to wind load (UNI EN 12210)

-Class C5

Resistance to drive force (UNI EN 13115)

-Class 1 – < 100 N

Test for vertical load and static torsion (UNI EN 13115)

-Class 4 – 800 N / 350 N

Resistance to repeated opening and closing (UNI EN 12400)

-Class 2 - 10,000 opening and closing

**Limiti dimensionali - Maximum dimension**

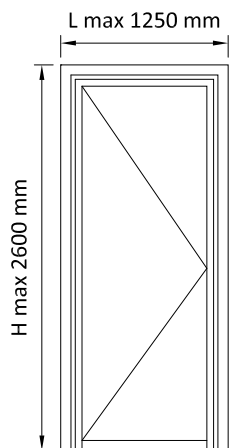

porta ad un'anta  
one-leaf doors

peso massimo anta\*  
maximum leaf weight\*

- AC1033 - 160 kg
- AC1058 - 180 kg
- AC6023 - 200 kg
- AC1037 - 250 kg

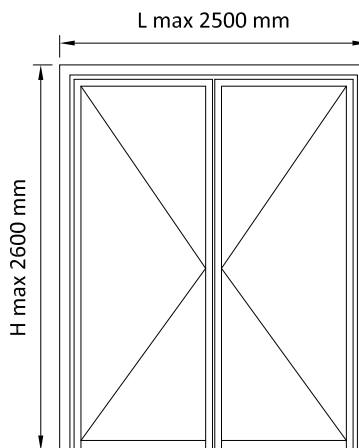

porta a due ante  
two-leaf doors

peso massimo anta\*  
maximum leaf weight\*

- AC1033 - 160 kg
- AC1058 - 180 kg
- AC6023 - 200 kg
- AC1037 - 250 kg

\* cerniera aggiuntiva per H serramento > 2200 mm  
additional hinge for doors with height > 2200 mm

**Esempi tipologie realizzabili - Types of door**

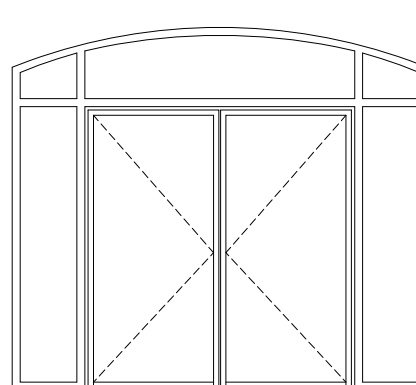
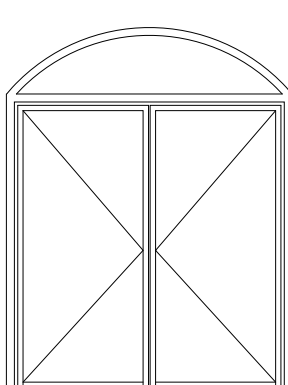
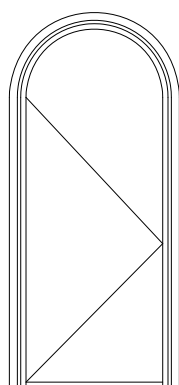
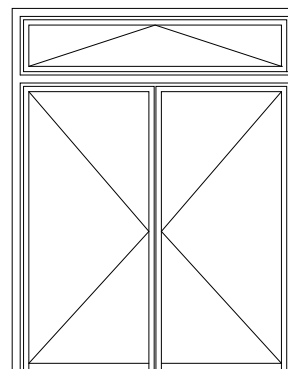
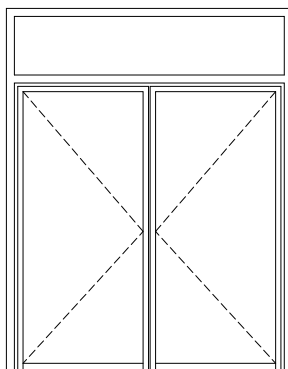
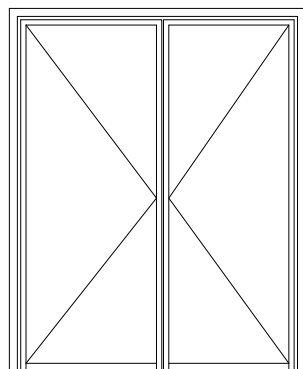
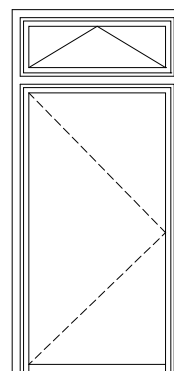
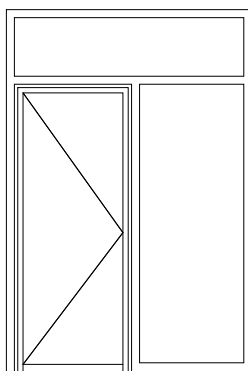
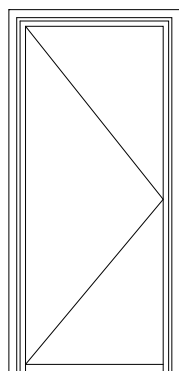

**Limiti dimensionali - Maximum dimension**

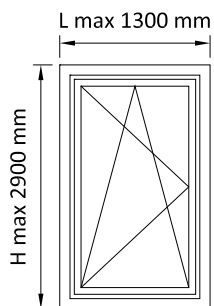

finestra ad un anta  
*one-leaf opening windows*

peso massimo anta  
*maximum leaf weight*

- AC1237 - 180 kg
- AC2632/C - 80 kg
- AGE271-2 - 150 kg Easy
- AG1273 - 80 kg Easy
- AG1278 - 80 kg Easy
- AGE281-2 - 130 kg Easy
- AGE291-2 - 130 kg Easy
- AGA271 - 180 kg Easy
- AG1271-2 - 150 kg RC2
- AG1281-2 - 130 kg RC2
- AG1291-2 - 130 kg RC2

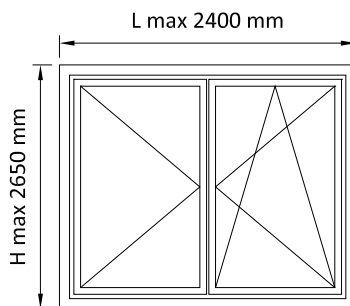

finestra a due ante  
*two-leaf opening windows*

peso massimo anta  
*maximum leaf weight*

- AC1237 - 180 kg
- AC2632/C - 80 kg
- AGE271-2-5-6 - 150 kg Easy
- AG1273 - 80 kg Easy
- AG1278 - 80 kg Easy
- AGE281-2-5-6 - 130 kg Easy
- AGE291-2-5-6 - 130 kg Easy
- AGE775-6 - 150 kg Easy
- AGE785-6 - 130 kg Easy
- AGE795-6 - 130 kg Easy
- AGA271-5 - 180 kg Easy
- AG1271-2-5-6 - 150 kg RC2
- AG1281-2-5-6 - 130 kg RC2
- AG1291-2-5-6 - 130 kg RC2

**Esempi tipologie realizzabili - Types of window**

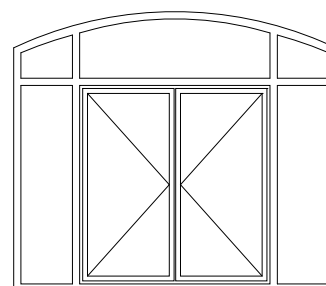
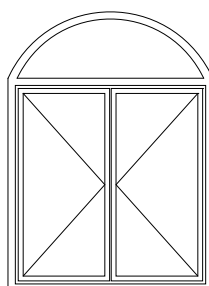
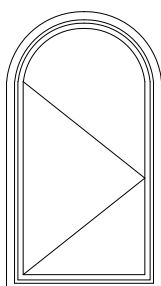
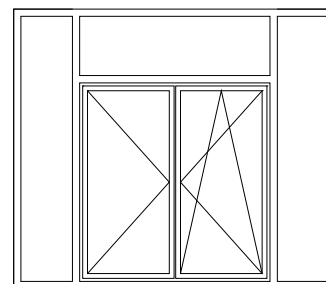
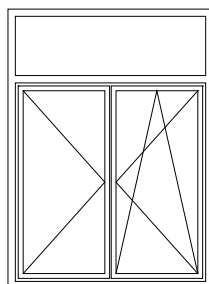
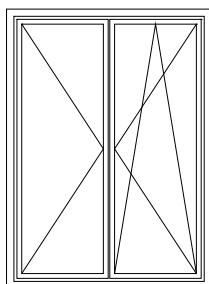
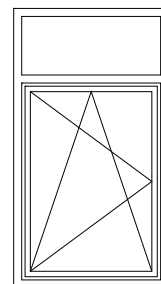
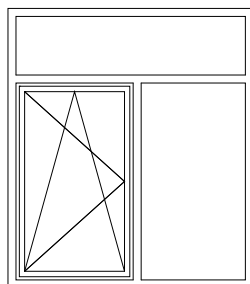
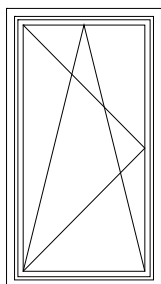



**Limiti dimensionali - Maximum dimension**

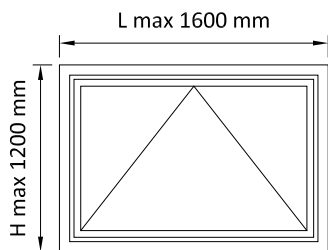

finestra a vasistas  
*bottom-hung window*

peso massimo anta  
*maximum leaf weight*

AG1264 - AG1274  
AC2632/C - 100 kg  
AC1221 - 100 kg  
AG1224 - 100 kg

ferramenta e cremonese  
*hardware and cremone*

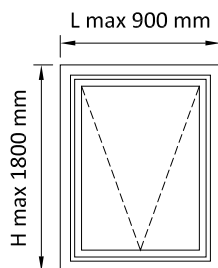

finestra a sporgere  
*awning window*

peso massimo anta  
*maximum leaf weight*

AC1046 - 75 kg  
AC1046M - 120 kg

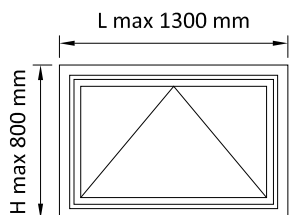

finestra a vasistas  
*bottom-hung window*

peso massimo anta  
*maximum leaf weight*

AC1235  
AC2632/C - 70 kg  
AC1221 - 70 kg  
AG1224 - 70 kg

braccetti e cricchetto  
*stays and finger catch*

**Esempi tipologie realizzabili - Types of window**

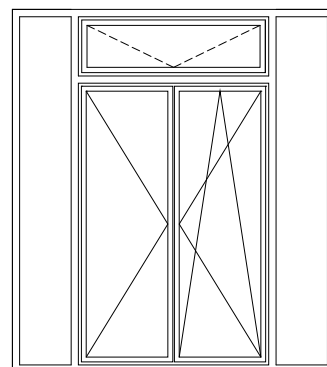
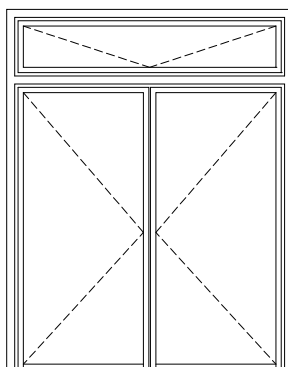
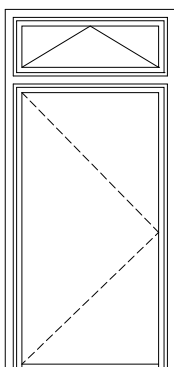
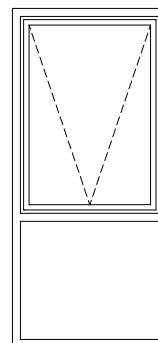
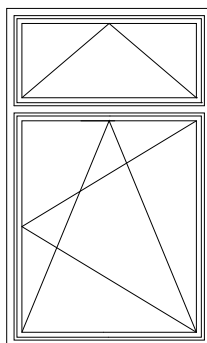
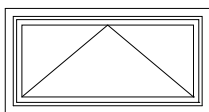

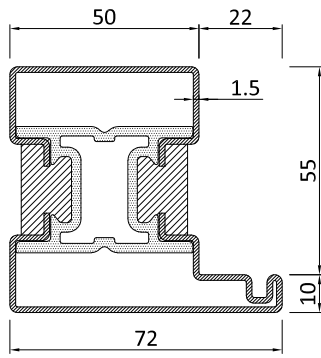

P.1001

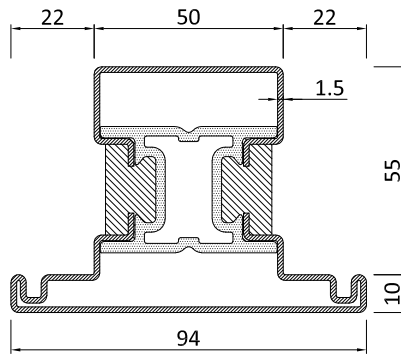

P.1002

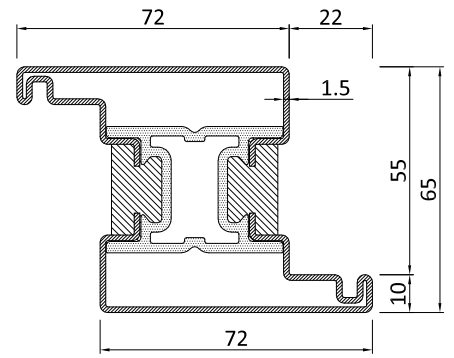

P.1003

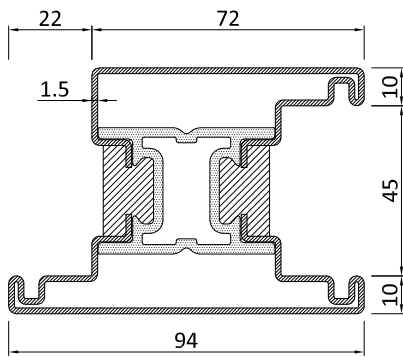

P.1005

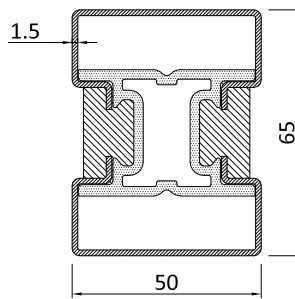

P.1010

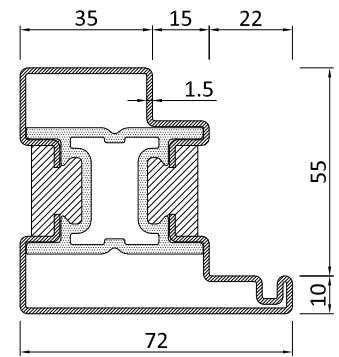

P.1011

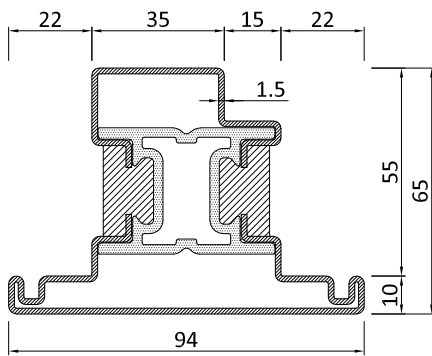

P.1012

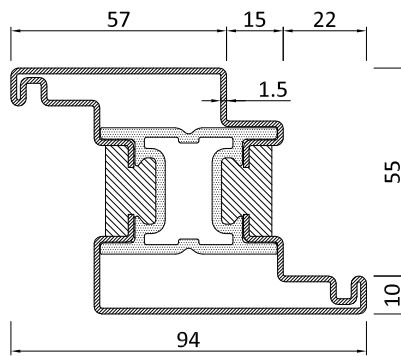

P.1013

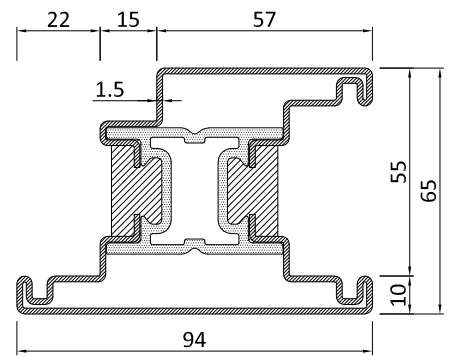

P.1015

Profilo / Profile n°	P Kg/m		A m <sup>2</sup> /m	Jx cm <sup>4</sup>	Jy cm <sup>4</sup>	L m	Profilo / Profile n°	P Kg/m		A m <sup>2</sup> /m	Jx cm <sup>4</sup>	Jy cm <sup>4</sup>	L m
	ZN / I - CT	OT						ZN / I - CT	OT				
P.1001	4,36	4,62	0,31	19,04	21,92	6	P.1011	4,32	4,58	0,31	17,66	21,11	6
P.1002	4,90	4,62	0,36	20,90	37,36	6	P.1012	4,86	5,16	0,36	19,40	36,22	6
P.1003	4,93	5,25	0,36	22,75	34,49	6	P.1013	4,92	5,23	0,36	21,72	33,08	6
P.1005	5,47	5,83	0,42	25,18	47,37	6	P.1015	5,46	5,81	0,42	24,05	45,72	6
P.1010	3,79	3,99	0,26	16,15	12,17	6							

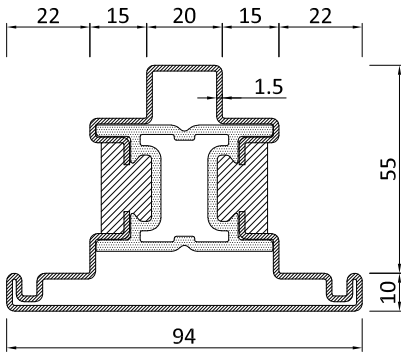

P.1022 Non fornito in acciaio zincato  
Not in galvanized steel

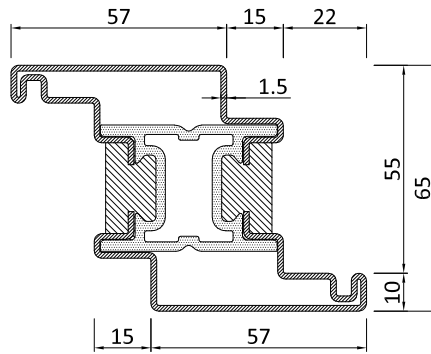

P.1023

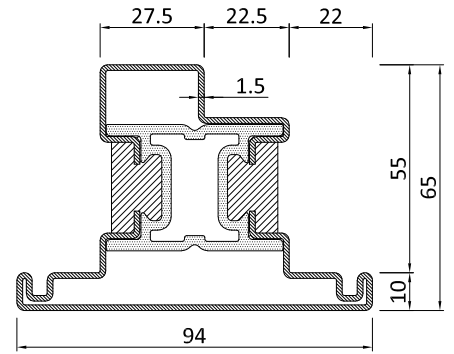

P.1027

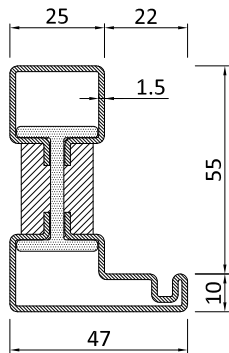

P.1201

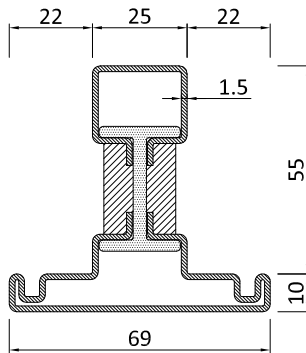

P.1202

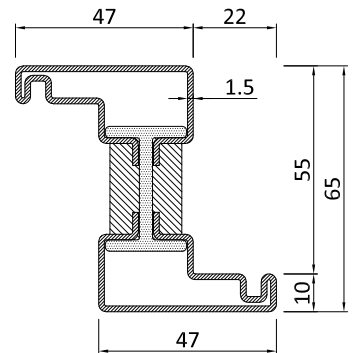

P.1203

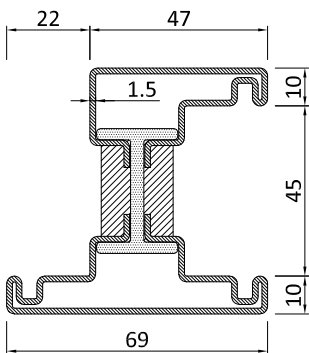

P.1205

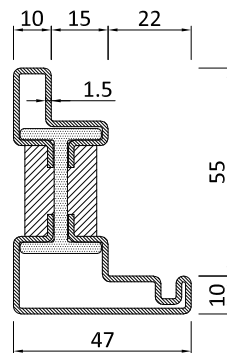

P.1211

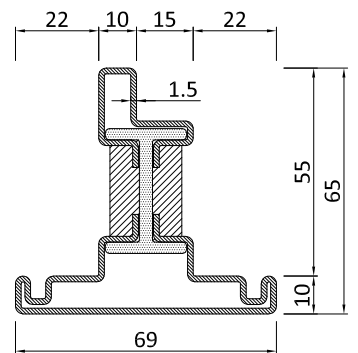

P.1212

Profilo / Profile n°	P Kg/m		A m <sup>2</sup> /m	Jx cm <sup>4</sup>	Jy cm <sup>4</sup>	L m	Profilo / Profile n°	P Kg/m		A m <sup>2</sup> /m	Jx cm <sup>4</sup>	Jy cm <sup>4</sup>	L m
	ZN / I-CT	OT						ZN / I-CT	OT				
P.1022	4,92	4,94	0,36	17,83	35,22	6	P.1203	3,82	4,08	0,31	18,68	12,71	6
P.1023	4,91	5,21	0,36	20,72	31,70	6	P.1205	4,37	4,68	0,37	21,38	18,76	6
P.1027	4,90	5,20	0,36	18,65	36,05	3	P.1211	3,22	3,43	0,36	12,71	6,56	6
P.1201	3,24	3,45	0,26	14,29	6,59	6	P.1212	3,77	4,03	0,31	14,44	13,83	6
P.1202	3,79	4,05	0,31	16,17	14,14	6							

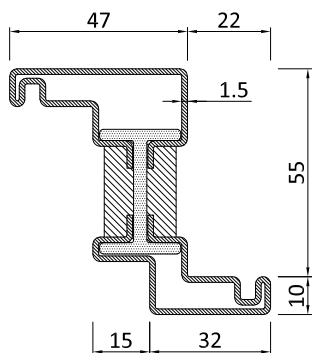

P.1213

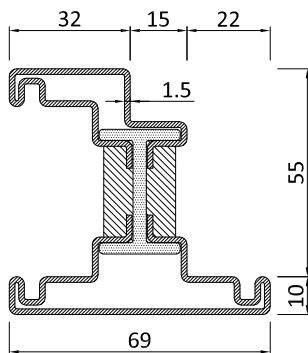

P.1215

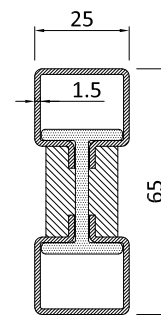

P.1220

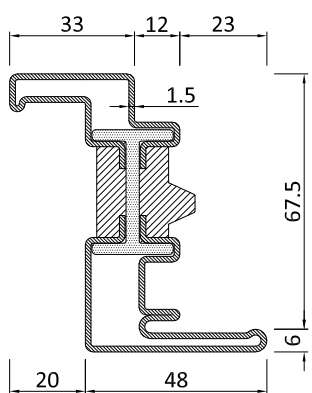

P.1233

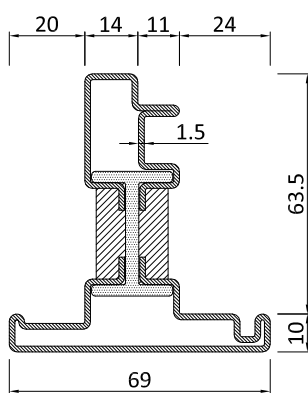

P.1724

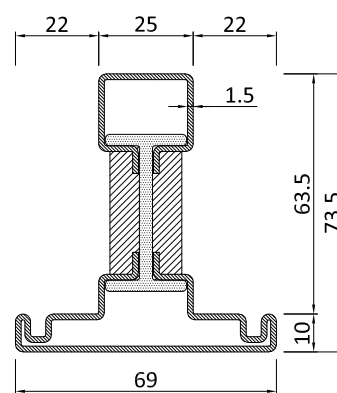

P.1702

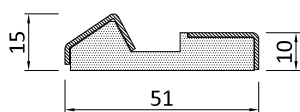

P.1030

Profilo / Profile n°	P Kg/m		A m <sup>2</sup> /m	Jx cm <sup>4</sup>	Jy cm <sup>4</sup>	L m	Profilo / Profile n°	P Kg/m		A m <sup>2</sup> /m	Jx cm <sup>4</sup>	Jy cm <sup>4</sup>	L m
	ZN / I - CT	OT						ZN / I - CT	OT				
P.1213	3,77	4,03	0,31	17,56	12,21	6	P.1702	3,98	4,24	0,33	19,28	14,14	6
P.1215	4,32	4,63	0,36	20,13	18,06	6	P.1030	1,46	1,53	0,14			3
P.1220	2,66	2,82	0,21	11,11	2,16	6							
P.1233	4,21	4,50	0,35	24,52	9,86	6							
P.1724	4,10	4,38	0,34	20,15	13,34	6							

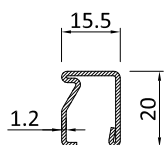

P.2007

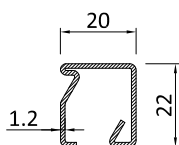

P.1007

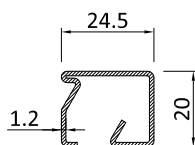

P.2008

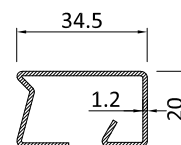

P.2009

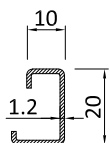

P.2015

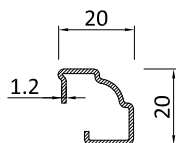

P.2028

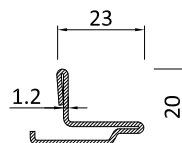

P.2038

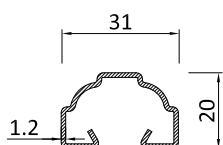

P.2030

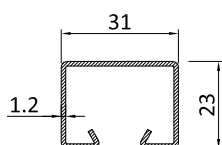

P.2031

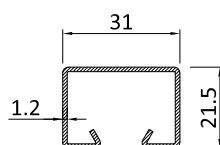

P.2032

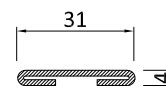

P.2034

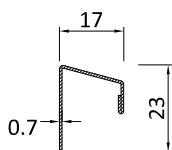

P.2027

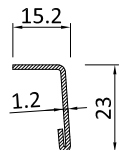

P.1129

MATERIALE | MATERIAL

PZ \_\_\_\_\_ acciaio zincato | *galvanized steel*

PC \_\_\_\_\_ GZ acciaio corten grezzo | *untreated corteen steel*

PI \_\_\_\_\_ ST acciaio inox satinato | *satined stainless steel*

PI \_\_\_\_\_ SB acciaio inox scotch brite | *scotch brite stainless steel*

PI \_\_\_\_\_ L3 acciaio inox lucido | *polished stainless steel*

PB \_\_\_\_\_ BR ottone grezzo | *untreated brass*

Profilo / Profile n°	P Kg/m		A m <sup>2</sup> /m	Jx cm <sup>4</sup>	Jy cm <sup>4</sup>	L m
	ZN / I - CT	OT				
P.2007	0,57	0,62	0,13			6
P.1007	0,70	0,75	0,16			6
P.2008	0,75	0,82	0,17			6
P.2009	0,91	0,99	0,20			6
P.2015	0,43	0,46	0,09			6
P.2028	0,48	0,52	0,11			6
P.2038	0,68	0,74	0,16			6
P.2030	0,73	0,79	0,17			6
P.2031	0,98	1,06	0,20			4
P.2032	0,95	1,03	0,19			4

Profilo / Profile n°	P Kg/m		A m <sup>2</sup> /m	Jx cm <sup>4</sup>	Jy cm <sup>4</sup>	L m
	ZN / I - CT	OT				
P.2034	0,51	0,56	0,10			4
P.2027	0,51	0,56	0,10			3
P.1129	0,41	0,44	0,06			3



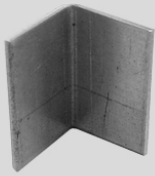

- AC1014 acciaio zincato | galvanized steel
- AC1014CZ acciaio corten | corten steel
- AC1014ST inox satinato | satined stainless steel
- AC1014SB inox scotch brite | scotch brite st. steel
- AC1014L3 inox lucido | polished stainless steel
- AC1014BR ottone naturale | natural brass

### AC 1014

Accessorio inversione battuta per porte  
P.1012-P.1013

n.2 pz. per ogni angolo

*Reverse closure kit for doors  
P.1012-P.1013*

*n. 2 pieces for each corner*



- AC1037SB inox scotch brite | scotch brite st. steel
- AC1037ST inox satinato | satined stainless steel
- AC1037L inox lucido | polished stainless steel
- AC1037B inox brunito | burnished stainless steel

### AC1037.

Cerniera a stilo ad avvitare con viti e rinforzi per porta  
Peso massimo anta: 250 kg

*Hinge to be screwed with screws and strengtheners for door  
Maximum leaf weight: 250 kg*

AISI 304

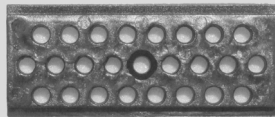

### AC 1020M

Supporto per spessore vetro  
Vetro da 23 a 44 mm

*Glass spacer  
Glass from 23 to 44 mm*

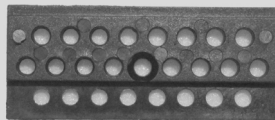

### AC 1020R

Supporto per spessore vetro  
Vetro fino a 22 mm

*Glass spacer  
Glass up to 22 mm*

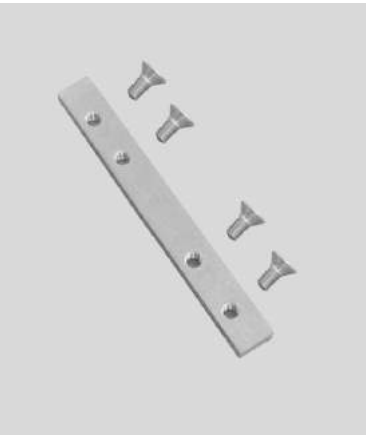

### AC 1037/R

Rinforzo cerniera AC1037 su profili ridotti

*Reinforcement for hinge AC1037 on reduced profiles*

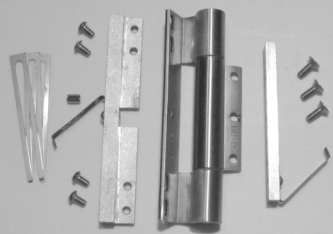

- AC1033IZ inox verniciabile | paintable stainless steel
- AC1033SB inox scotch brite | scotch brite st. steel
- AC1033ST inox satinato | satined stainless steel
- AC1033L inox lucido | polished stainless steel
- AC1033B inox brunito | burnished stainless steel
- AC1033CZ corten grezzo | untreated corten steel
- AC1033CT corten trattato | treated corten steel

### AC1033.

Cerniera a stilo ad avvitare con viti e rinforzi per porta  
Peso massimo anta: 160 kg

*Screw-on hinge with screws and strengtheners for door  
Maximum leaf weight: 160 kg*

AISI 304

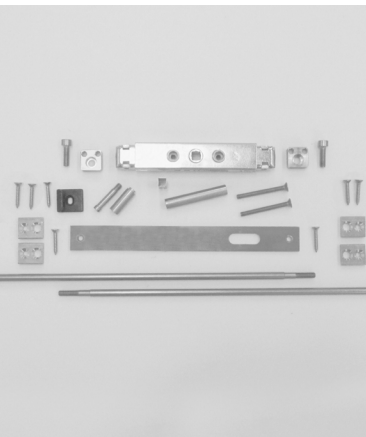

### AC 1039

Kit cremonese per chiusura orizzontale su sporgere

*Cremone bolt set for horizontal awning closing*



### AC 1033/R

Rinforzo cerniera AC1033 su profili ridotti

*Reinforcement for hinge AC1033 on reduced profiles*



### AC 1040

Kit chiusura porte seconda anta Acciaio inox

*Second leaf door closing kit  
Stainless steel*



**AC 1046**

Coppia compassi apertura a sporgere  
Acciaio inox  
Peso massimo anta: 75 kg

*Pair of side arms for awning opening  
Stainless steel  
Maximum leaf weight: 75 kg*

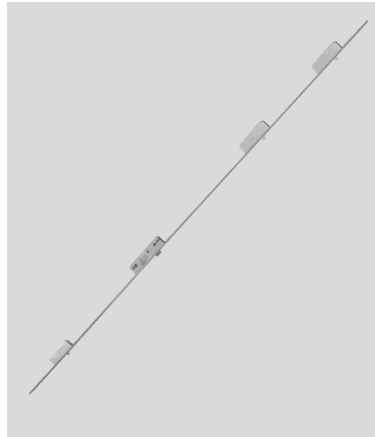

**AC 1067W D-S**

Serratura multipunto  
Altezza anta oltre 2900 mm

*Multipoint lock  
Leaf height over 2900 mm*

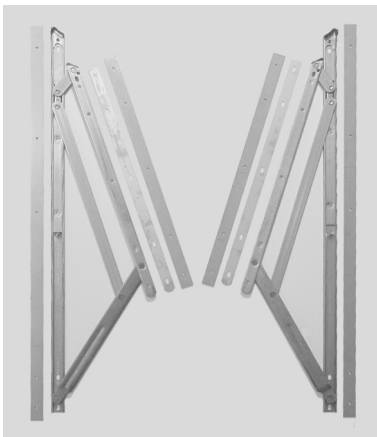

**AC 1046M**

Coppia compassi apertura a sporgere  
Acciaio inox  
Peso massimo anta: 120 kg

*Pair of side arms for awning opening  
Stainless steel  
Maximum leaf weight: 120 kg*

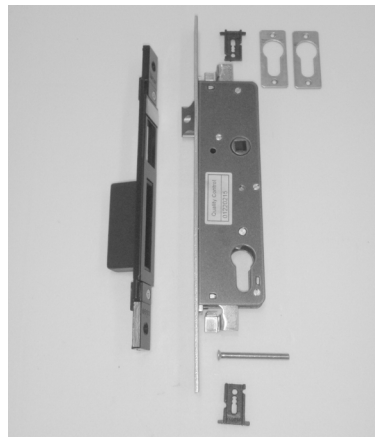

**AC 1070**

Serratura con scrocco e catenaccio

*Lock with spring latch and bolt*

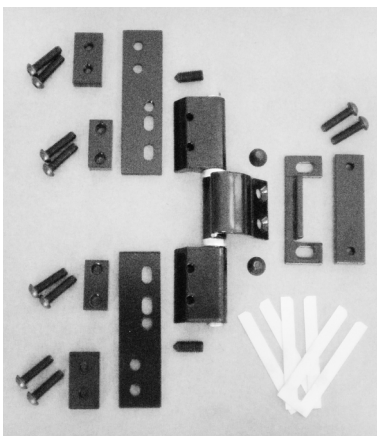

**AC 1058**

Cerniera a scomparsa per porta  
Peso massimo anta: 180 kg  
Massima apertura: 96°

*Concealed hinge for door  
Maximum leaf weight: 180 kg  
Maximum opening: 96°*

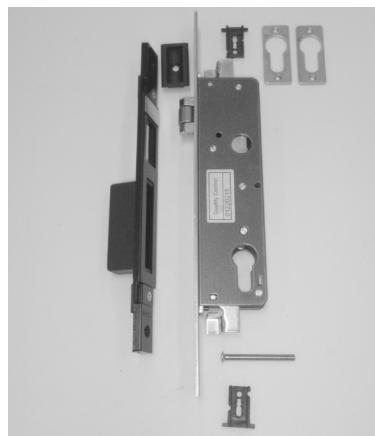

**AC 1071**

Serratura con rullo e catenaccio

*Lock with roller and bolt*



**AC 1065W D-S**

Serratura multipunto  
Altezza anta da 2000 a 2300 mm

*Multipoint lock  
Leaf height from 2000 to 2300 mm*

**AC 1066W D-S**

Serratura multipunto  
Altezza anta da 2301 a 2900 mm

*Multipoint lock  
Leaf height from 2301 to 2900 mm*

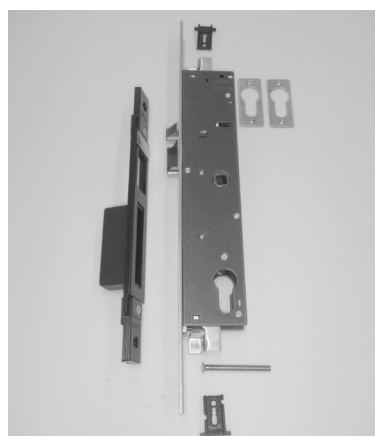

**AC 1072**

Elettroserratura

*Electric lock*



**AC 1075**

Deviatore per triplice chiusura  
*Deviator for three-point lock*



**AC 1215**

Kit inversione battuta finestra  
A/R a due ante - nodo ZTZ  
*Reverse closing 2nd-leaf  
Tilt&Turn window - ZTZ profiles*

AC1215 acciaio zincato | *galvanized steel*  
AC1215CZ acciaio corten | *corten steel*  
AC1215I acciaio inox | *stainless steel*  
AC1215B inox brunito | *burnished stainless steel*



**AC 1080I**

Rostro di sicurezza in acciaio inox  
Completo di viti e rinforzi  
*Stainless steel security pin  
With screws and strengtheners*



**AC 1219.**

Scarico acqua per aperture  
interne in metallo  
*Metal drip for inward openings*

AC1219IZ inox verniciabile | *paintable stainless steel*  
AC1219SB inox scotch brite | *scotch brite st. steel*  
AC1219L inox lucido | *polished stainless steel*  
AC1219B inox brunito | *burnished stainless steel*  
AC1219CZ corten grezzo | *untreated corten steel*

**AC 1219NE**

Scarico acqua per aperture  
interne in plastica nera

*Black plastic drip for inward  
openings*

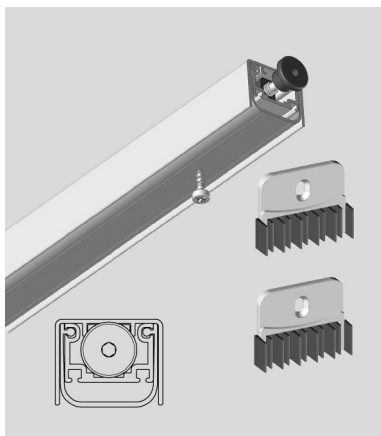

**AC 1081**

Paraspiffero automatico a  
ghigliottina  
*Guillotine type draught excluder*  
  
Dimensioni anta | *Leaf dimension*

AC1081/A: 615 → 730 mm  
AC1081/B: 715 → 830 mm  
AC1081/C: 815 → 930 mm  
AC1081/D: 915 → 1030 mm  
AC1081/E: 1015 → 1130 mm  
AC1081/F: 1115 → 1230 mm



**AC 1221.**

Cerniera in acciaio inox a tre ali  
ad avvitare per vasistas  
Peso massimo anta: 70-100 kg  
*Stainless steel hinge to be  
screwed for bottom-hung  
window  
Maximum leaf weight: 70-100 kg*

AC1221SB inox scotch brite | *scotch brite st. steel*  
AC1221L inox lucido | *polished stainless steel*  
AC1221B inox brunito | *burnished stainless steel*

AISI 316

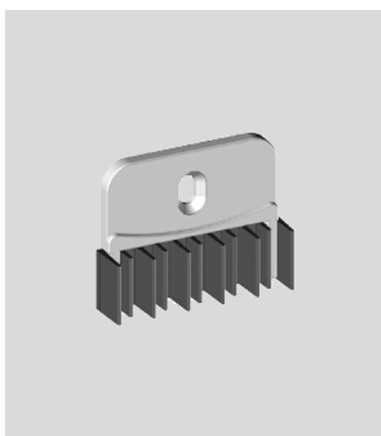

**AC 1081 AT**

Accessorio di battuta  
*Stop accessory*

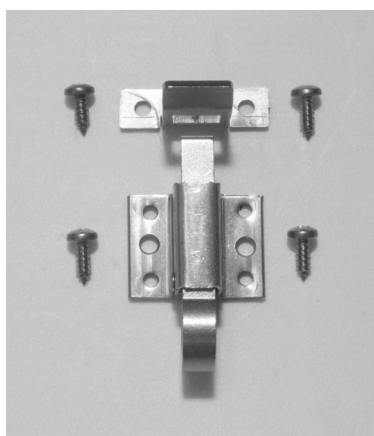

**AC 1223I**

Cricchetto ed incontro da  
avvitare in acciaio inox, per  
vasistas  
*Screw-in latch and plate in  
stainless steel, for bottom-hung  
windows*



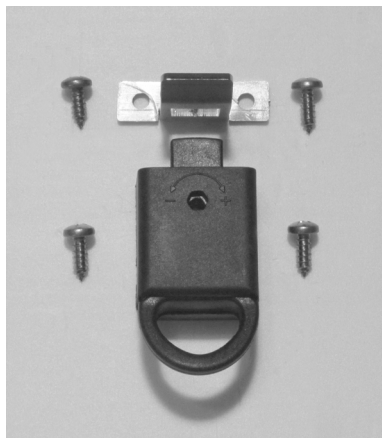

**AC 1231S**

Cricchetto ed incontro da avvitare in nylon nero, per vasistas

*Screw-in latch and plate in black nylon, for bottom-hung windows*



**AC 1714.**

Kit inversione battuta per finestra a due ante con fondini a saldare e in gomma - nodo TZ

*Reverse closure kit for 2-leaf window weld-on fitting and rubber fitting - TZ profiles*

AC1714GZ acciaio zincato | galvanized steel  
AC1714CZ acciaio corten | corten steel  
AC1714I acciaio inox | stainless steel  
AC1714B ottone naturale | natural brass



**AC 1235**

Coppia limitatori per apertura a vasistas  
H min = 360 mm  
Peso massimo anta: 70 kg

*Friction stays for bottom-hung windows  
H min = 360 mm  
Maximum leaf weight: 70 kg*

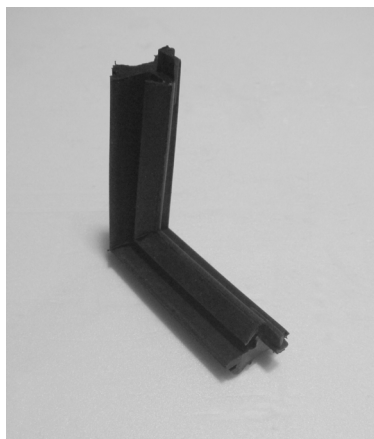

**AC 1716**

Guarnizione d'angolo vulcanizzata per GE1701

*Vulcanised corner gasket for GE1701*



**AC 1237.**

Cerniera a stilo ad avvitare con viti e rinforzi per finestra  
Peso massimo anta: 180 kg

*Hinge to be screwed with screws and strengtheners for window  
Maximum leaf weight: 180 kg*

AC1237IZ inox verniciabile | paintable stainless steel  
AC1237SB inox scotch brite | scotch brite st. steel  
AC1237L inox lucido | polished stainless steel  
AC1237B inox brunito | burnished stainless steel

AISI 304

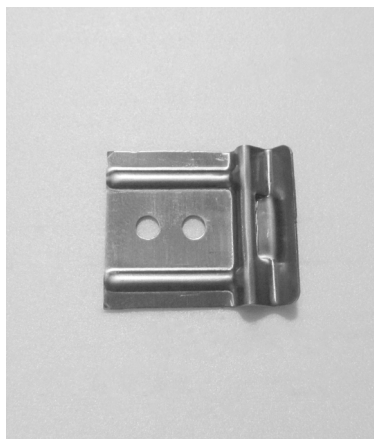

**AC 2608**

Clips per fissaggio fermavetri P.2015 - P.2028 - P.2038

*Clips for glazing bead P.2015 - P.2028 - P.2038*



**AC 1356**

Meccanismo DK esterno per maniglie "Vitruvio"

*External tilt and turn mechanism for "Vitruvio" handles*



**AC 2632/C**

Cerniera registrabile a due ali in acciaio zincato a saldare | Ø 16  
Peso massimo anta: 100 kg

*Adjustable weld-on hinge in galvanized steel | Ø 16  
Maximum leaf weight: 100 kg*

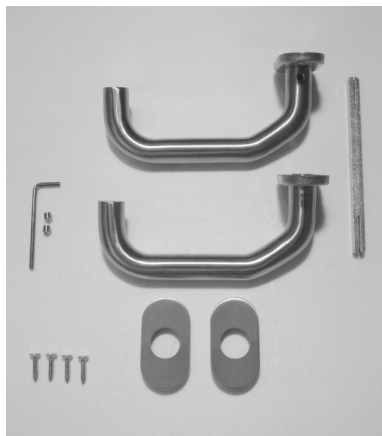
**AC 5002**

Coppia di maniglie per porta in acciaio inox completa di viti

*Pair of stainless steel door handles with screws*

**AG 1224**

Cerniera a tre ali ad avvitare per vasistas  
Peso massimo anta: 70-100 kg

*Screw-on hinge for bottom-hung window  
Maximum leaf weight: 70-100 kg*

**AC 5037**

Maniglia con incontro in lega colore nero per apertura a sporgere  
Completa di viti di fissaggio

*Handle with black alloy plate for projecting opening  
With fixing screws*

**AG 1224 ..**

Kit copertine in plastica per cerniere AG 1224

*Plastic cover for hinges AG 1224*

AG1224/C argento | matt silver  
AG1224MC marrone | brown  
AG1224BC bronzato chiaro | light bronze plated  
AG1224BO ottonato opaco | matt brass plated  
AG1224OL ottonato lucido | brass plated  
AG1224ST inox | stainless steel  
AG1224GR grigio | gray  
AG1224NI nichelato | nickel  
AG1224WB bianco RAL 9001 | white RAL 9001  
AG1224WC bianco RAL 9010 | white RAL 9010

**AC 5056**

Maniglia DK per cremonese in acciaio inox scotch brite per P.1233  
Completa di viti

*DK handle for cremone bolt in scotch-brite stainless steel for P.1233  
With fixing screws*

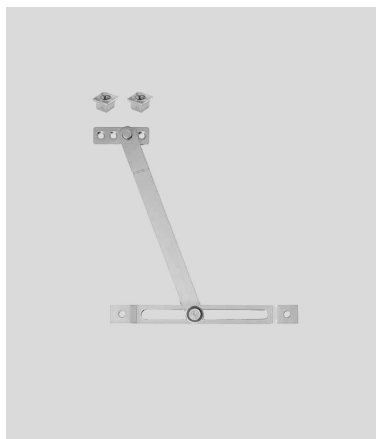
**AG 1385**

Limitatore di apertura frizionato per meccanismi A/R a vista  
Solo per meccanismi EASY

*Friction stay for tilt-turn mechanism, visible hinges  
Only for EASY mechanism*

**AC 6023**

Cerniera registrabile a due ali in acciaio zincato a saldare | Ø 20  
Peso massimo anta: 200 kg

*Adjustable weld-on hinge in galvanised steel | Ø 20  
Maximum leaf weight: 200 kg*

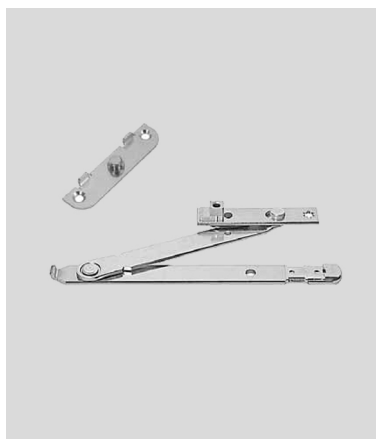
**AG 1386**

Limitatore di apertura frizionato per meccanismi A/R a scomparsa  
Solo per meccanismi EASY

*Friction stay for tilt-turn mechanism, concealed hinges  
Only for EASY mechanism*

**AG 6530**

Limitatore di corsa per  
meccanismi A/R

*Opening limiter on tilt&turn  
mechanism*

**CV 5001.**

Vite per boccola fermavetri

*Screw for glazing bead bushing*

TPS 4.2x16 mm

**CV 5012.**

Boccola per fermavetri

*Bushing for glazing bead*

CV5001 acciaio zincato | *galvanized steel*  
CV50011 acciaio inox | *stainless steel*

CV5012 acciaio zincato | *galvanized steel*  
CV50121 acciaio inox | *stainless steel*

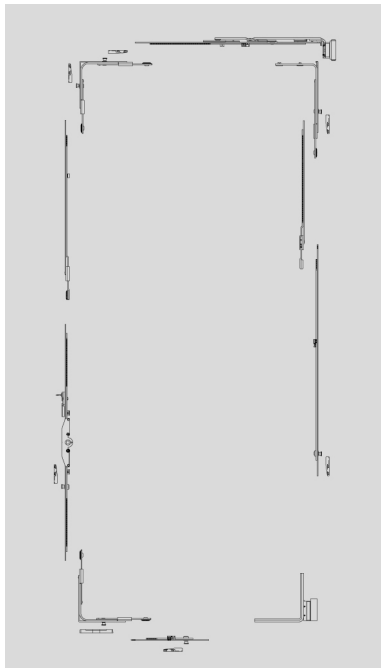

**AGE 271**

Meccanismo A/R prima anta Dx cerniere a vista

*First leaf RH tilt-turn mechanism with visible hinges*

EASY

**AGE 272**

Meccanismo A/R prima anta Sx cerniere a vista

*First leaf LH tilt-turn mechanism with visible hinges*

EASY

		altezza - height								
		661	861	1001	1201	1401	1601	1801	2001	2201
		860	1000	1200	1400	1600	1800	2000	2200	2400
	<b>601-800</b>	A1	B1	C1	D1	E1	F1	G1	H1	I1
larghezza width	<b>801-1000</b>	-	B2	C2	D2	E2	F2	G2	H2	I2
	<b>1001-1200</b>	-	-	C3	D3	E3	F3	G3	H3	I3
	<b>1201-1400</b>	-	-	-	D4	E4	F4	G4	H4	I4

**Limiti dimensionali | Limits**

Peso massimo anta | *Maximum leaf weight: 150 kg*

misure cava ferramenta - H>L | *hardware measure - H>W*

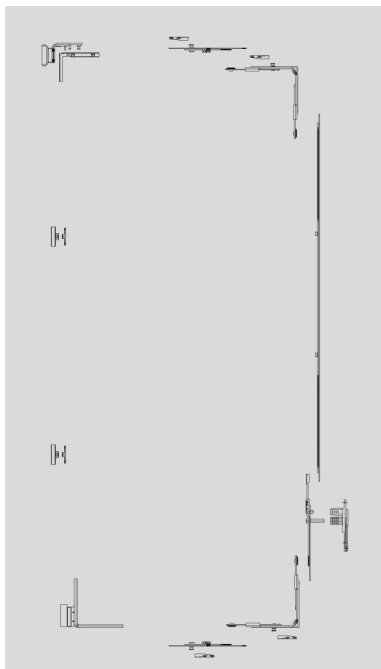

**AGE 275**

Meccanismo A/R seconda anta Dx cerniere a vista - Nodo ZTZ

*Second leaf RH tilt-turn mechanism with visible hinges - ZTZ profiles*

EASY

**AGE 276**

Meccanismo A/R seconda anta Sx cerniere a vista - Nodo ZTZ

*Second leaf LH tilt-turn mechanism with visible hinges - ZTZ profiles*

EASY

		altezza - height								
		661	861	1001	1201	1401	1601	1801	2001	2201
		860	1000	1200	1400	1600	1800	2000	2200	2400
	<b>601-800</b>	A1	B1	C1	D1	E1	F1	G1	H1	I1
larghezza width	<b>801-1000</b>	-	B2	C2	D2	E2	F2	G2	H2	I2
	<b>1001-1200</b>	-	-	C3	D3	E3	F3	G3	H3	I3
	<b>1201-1400</b>	-	-	-	D4	E4	F4	G4	H4	I4

**Limiti dimensionali | Limits**

Peso massimo anta | *Maximum leaf weight: 150 kg*

misure cava ferramenta - H>L | *hardware measure - H>W*

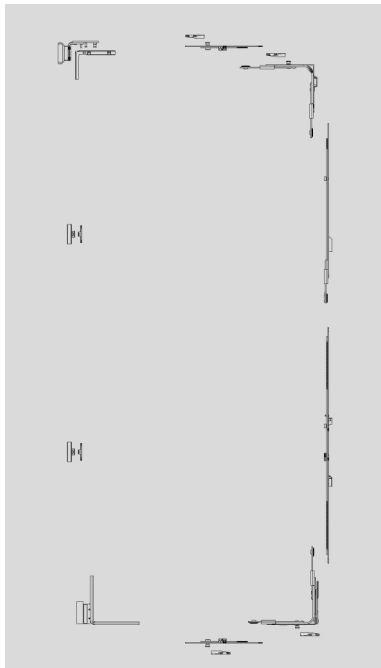

**AGE 775**

Meccanismo A/R seconda anta Dx cerniere a vista - Nodo TZ  
*Second leaf RH tilt-turn mechanism with visible hinges - TZ profiles*

EASY

**AGE 776**

Meccanismo A/R seconda anta Sx cerniere a vista - Nodo TZ  
*Second leaf LH tilt-turn mechanism with visible hinges - TZ profiles*

EASY

		altezza - height								
		661	861	1001	1201	1401	1601	1801	2001	2201
		860	1000	1200	1400	1600	1800	2000	2200	2400
	<b>601-800</b>	A1	B1	C1	D1	E1	F1	G1	H1	I1
larghezza width	<b>801-1000</b>	-	B2	C2	D2	E2	F2	G2	H2	I2
	<b>1001-1200</b>	-	-	C3	D3	E3	F3	G3	H3	I3
	<b>1201-1400</b>	-	-	-	D4	E4	F4	G4	H4	I4

**Limiti dimensionali | Limits**

Peso massimo anta | *Maximum leaf weight: 150 kg*  
 misure cava ferramenta - H>L | *hardware measure - H>W*



- AG127-/C argento | *matt silver*
- AG127-MC marrone | *brown*
- AG127-BC bronzato chiaro | *light bronze plated*
- AG127-BO ottonato opaco | *matt brass plated*
- AG127-OL ottonato lucido | *brass plated*
- AG127-ST inox | *stainless steel*
- AG127-NI nichelato | *nickel*
- AG127-WB bianco RAL 9001 | *white RAL 9001*
- AG127-WC bianco RAL 9010 | *white RAL 9010*

**AG 1271 ..**

Kit copertine destre in plastica  
 per kit A/R AGE 271-5

*Plastic right-cover kit for  
 tilt&turn for kit AGE 271-5*

**AG 1272 ..**

Kit copertine sinistre in plastica  
 per kit A/R AGE 272-6

*Plastic left-cover kit for tilt&turn  
 for kit AGE 272-6*

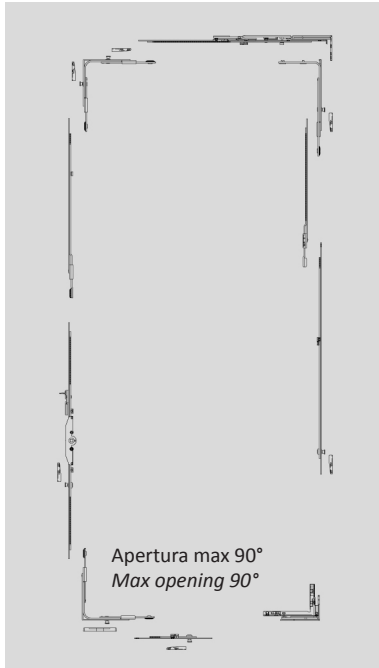

**AGE 281**

Meccanismo A/R prima anta Dx cerniere a scomparsa

*First leaf RH tilt-turn mechanism with concealed hinges*

EASY

**AGE 282**

Meccanismo A/R prima anta Sx cerniere a scomparsa

*First leaf LH tilt-turn mechanism with concealed hinges*

EASY

		altezza - height								
		661	861	1001	1201	1401	1601	1801	2001	2201
		860	1000	1200	1400	1600	1800	2000	2200	2400
	<b>601-800</b>	A1	B1	C1	D1	E1	F1	G1	H1	I1
larghezza width	<b>801-1000</b>	-	B2	C2	D2	E2	F2	G2	H2	I2
	<b>1001-1200</b>	-	-	C3	D3	E3	F3	G3	H3	I3
	<b>1201-1400</b>	-	-	-	D4	E4	F4	G4	H4	I4

**Limiti dimensionali | Limits**

Peso massimo anta | *Maximum leaf weight: 130 kg*

misure cava ferramenta - H>L | *hardware measure - H>W*

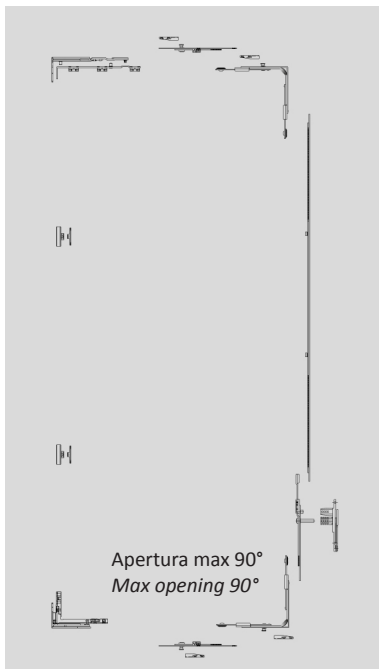

**AGE 285**

Meccanismo A/R seconda anta Dx cerniere a scomparsa - Nodo ZTZ

*Second leaf RH tilt-turn mechanism with concealed hinges - ZTZ profiles*

EASY

**AGE 286**

Meccanismo A/R seconda anta Sx cerniere a scomparsa - Nodo ZTZ

*Second leaf LH tilt-turn mechanism with concealed hinges - ZTZ profiles*

EASY

		altezza - height								
		661	861	1001	1201	1401	1601	1801	2001	2201
		860	1000	1200	1400	1600	1800	2000	2200	2400
	<b>601-800</b>	A1	B1	C1	D1	E1	F1	G1	H1	I1
larghezza width	<b>801-1000</b>	-	B2	C2	D2	E2	F2	G2	H2	I2
	<b>1001-1200</b>	-	-	C3	D3	E3	F3	G3	H3	I3
	<b>1201-1400</b>	-	-	-	D4	E4	F4	G4	H4	I4

**Limiti dimensionali | Limits**

Peso massimo anta | *Maximum leaf weight: 130 kg*

misure cava ferramenta - H>L | *hardware measure - H>W*

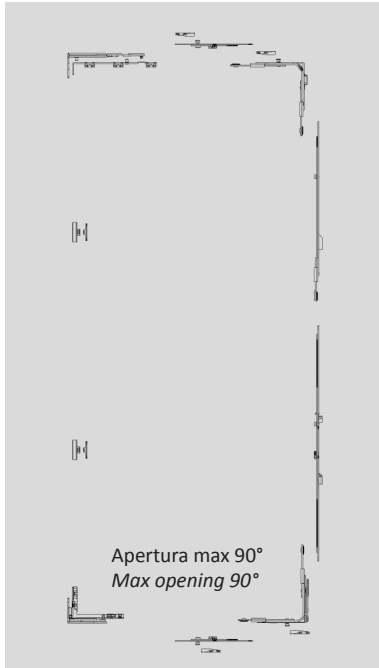

**AGE 785**

Meccanismo A/R seconda anta Dx cerniere a scomparsa - Nodo TZ

*Second leaf RH tilt-turn mechanism with concealed hinges - TZ profiles*

**EASY**

**AGE 786**

Meccanismo A/R seconda anta Sx cerniere a scomparsa - Nodo TZ

*Second leaf LH tilt-turn mechanism with concealed hinges - TZ profiles*

**EASY**

		altezza - height								
		661	861	1001	1201	1401	1601	1801	2001	2201
		860	1000	1200	1400	1600	1800	2000	2200	2400
larghezza width	<b>601-800</b>	A1	B1	C1	D1	E1	F1	G1	H1	I1
	<b>801-1000</b>	-	B2	C2	D2	E2	F2	G2	H2	I2
	<b>1001-1200</b>	-	-	C3	D3	E3	F3	G3	H3	I3
	<b>1201-1400</b>	-	-	-	D4	E4	F4	G4	H4	I4

**Limiti dimensionali | Limits**

Peso massimo anta | *Maximum leaf weight: 130 kg*

misure cava ferramenta - H>L | *hardware measure - H>W*

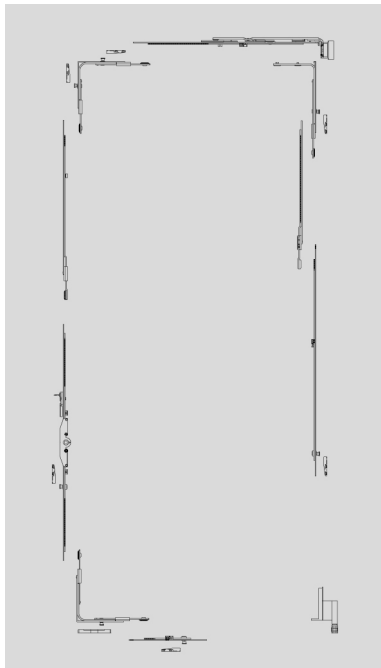

**AGE 291**

Meccanismo A/R prima anta Dx cerniere a vista in acciaio inox  
*First leaf RH tilt-turn mechanism with visible stainless steel hinges*

EASY

**AGE 292**

Meccanismo A/R prima anta Sx cerniere a vista in acciaio inox  
*First leaf LH tilt-turn mechanism with visible stainless steel hinges*

EASY

		altezza - height								
		661	861	1001	1201	1401	1601	1801	2001	2201
		860	1000	1200	1400	1600	1800	2000	2200	2400
	<b>601-800</b>	A1	B1	C1	D1	E1	F1	G1	H1	I1
larghezza width	<b>801-1000</b>	-	B2	C2	D2	E2	F2	G2	H2	I2
	<b>1001-1200</b>	-	-	C3	D3	E3	F3	G3	H3	I3
	<b>1201-1400</b>	-	-	-	D4	E4	F4	G4	H4	I4

**Limiti dimensionali | Limits**

Peso massimo anta | *Maximum leaf weight: 130 kg*  
misure cava ferramenta - H>L | *hardware measure - H>W*

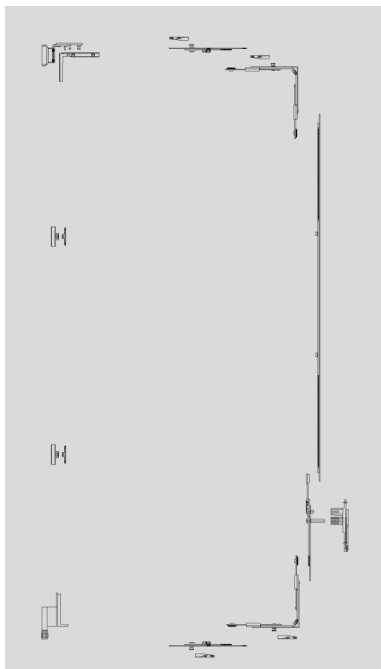

**AGE 295**

Meccanismo A/R seconda anta Dx cerniere a vista in acciaio inox - Nodo ZTZ  
*Second leaf RH tilt-turn mechanism with visible stainless steel hinges - ZTZ profiles*

EASY

**AGE 296**

Meccanismo A/R seconda anta Sx cerniere a vista in acciaio inox - Nodo ZTZ  
*Second leaf LH tilt-turn mechanism with visible stainless steel hinges - ZTZ profiles*

EASY

		altezza - height								
		661	861	1001	1201	1401	1601	1801	2001	2201
		860	1000	1200	1400	1600	1800	2000	2200	2400
	<b>601-800</b>	A1	B1	C1	D1	E1	F1	G1	H1	I1
larghezza width	<b>801-1000</b>	-	B2	C2	D2	E2	F2	G2	H2	I2
	<b>1001-1200</b>	-	-	C3	D3	E3	F3	G3	H3	I3
	<b>1201-1400</b>	-	-	-	D4	E4	F4	G4	H4	I4

**Limiti dimensionali | Limits**

Peso massimo anta | *Maximum leaf weight: 130 kg*  
misure cava ferramenta - H>L | *hardware measure - H>W*



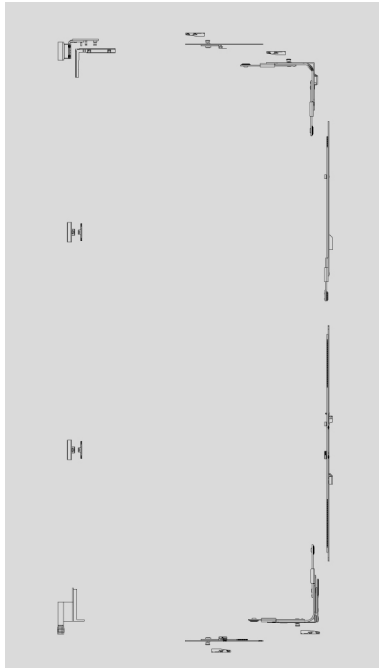

**AGE 795**

Meccanismo A/R seconda anta Dx cerniere a vista in acciaio inox - Nodo TZ

*Second leaf RH tilt-turn mechanism with visible stainless steel hinges - TZ profiles*

**EASY**

**AGE 796**

Meccanismo A/R seconda anta Sx cerniere a vista in acciaio inox - Nodo TZ

*Second leaf LH tilt-turn mechanism with visible stainless steel hinges - TZ profiles*

**EASY**

		altezza - height								
		661	861	1001	1201	1401	1601	1801	2001	2201
		860	1000	1200	1400	1600	1800	2000	2200	2400
larghezza width	<b>601-800</b>	A1	B1	C1	D1	E1	F1	G1	H1	I1
	<b>801-1000</b>	-	B2	C2	D2	E2	F2	G2	H2	I2
	<b>1001-1200</b>	-	-	C3	D3	E3	F3	G3	H3	I3
	<b>1201-1400</b>	-	-	-	D4	E4	F4	G4	H4	I4

**Limiti dimensionali | Limits**

Peso massimo anta | *Maximum leaf weight: 130 kg*

misure cava ferramenta - H>L | *hardware measure - H>W*

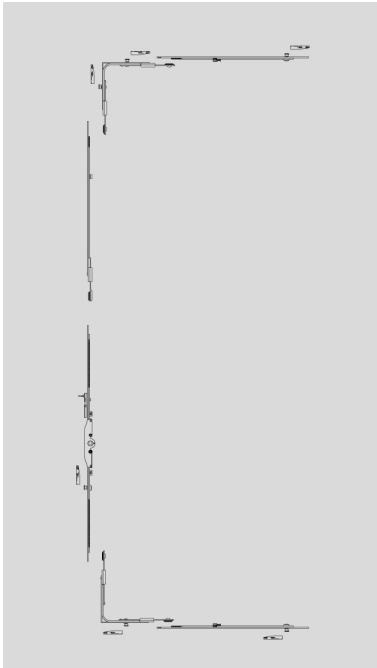

**AGA 271**

Meccanismo di chiusura anta principale Dx o Sx con telaio sui quattro lati, cerniere escluse

*Master leaf RH or LH locking mechanism on four sides, hinges excluded*

**EASY**

		altezza - height								
		661	861	1001	1201	1401	1601	1801	2001	2201
		860	1000	1200	1400	1600	1800	2000	2200	2400
larghezza width	601-800	A1	B1	C1	D1	E1	F1	G1	H1	I1
	801-1000	-	B2	C2	D2	E2	F2	G2	H2	I2
	1001-1200	-	-	C3	D3	E3	F3	G3	H3	I3
	1201-1400	-	-	-	D4	E4	F4	G4	H4	I4

**Limiti dimensionali | Limits**

misure cava ferramenta - H>L | hardware measure - H>W

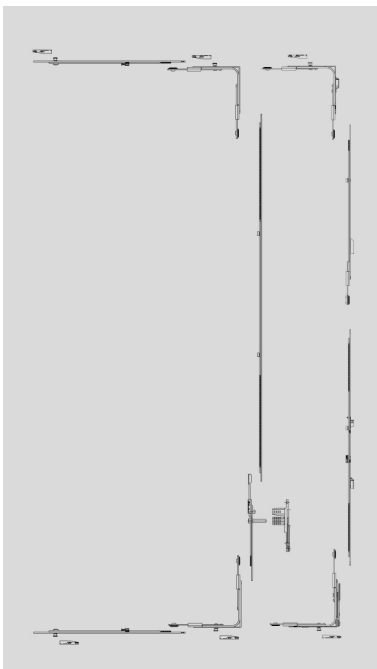

**AGA 275**

Meccanismo di chiusura seconda anta Dx o Sx con telaio sui quattro lati, cerniere escluse - nodo ZTZ

*Second leaf RH or LH locking mechanism on four sides, hinges excluded - ZTZ profiles*

**EASY**

**AGA 775**

Meccanismo di chiusura seconda anta Dx o Sx con telaio sui quattro lati, cerniere escluse - nodo TZ

*Second leaf RH or LH locking mechanism on four sides, hinges excluded - TZ profiles*

**EASY**

		altezza - height								
		661	861	1001	1201	1401	1601	1801	2001	2201
		860	1000	1200	1400	1600	1800	2000	2200	2400
larghezza width	601-800	A1	B1	C1	D1	E1	F1	G1	H1	I1
	801-1000	-	B2	C2	D2	E2	F2	G2	H2	I2
	1001-1200	-	-	C3	D3	E3	F3	G3	H3	I3
	1201-1400	-	-	-	D4	E4	F4	G4	H4	I4

**Limiti dimensionali | Limits**

misure cava ferramenta - H>L | hardware measure - H>W

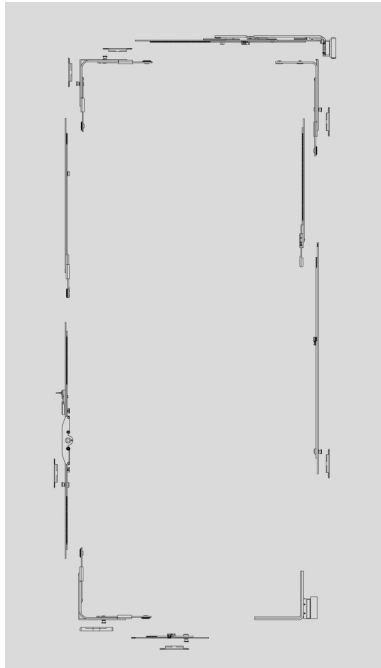

**AG 1271**

Meccanismo A/R prima anta Dx cerniere a vista  
*First leaf RH tilt-turn mechanism with visible hinges*

RC2 (no su profili in ottone | *not on brass profiles*)

**AG 1272**

Meccanismo A/R prima anta Sx cerniere a vista  
*First leaf LH tilt-turn mechanism with visible hinges*

RC2 (no su profili in ottone | *not on brass profiles*)

		altezza - height								
		661	861	1001	1201	1401	1601	1801	2001	2201
		860	1000	1200	1400	1600	1800	2000	2200	2400
larghezza width	601-800	A1	B1	C1	D1	E1	F1	G1	H1	I1
	801-1000	-	B2	C2	D2	E2	F2	G2	H2	I2
	1001-1200	-	-	C3	D3	E3	F3	G3	H3	I3
	1201-1400	-	-	-	D4	E4	F4	G4	H4	I4

**Limiti dimensionali | Limits**

Peso massimo anta | *Maximum leaf weight: 150 kg*  
misure cava ferramenta - H>L | *hardware measure - H>W*

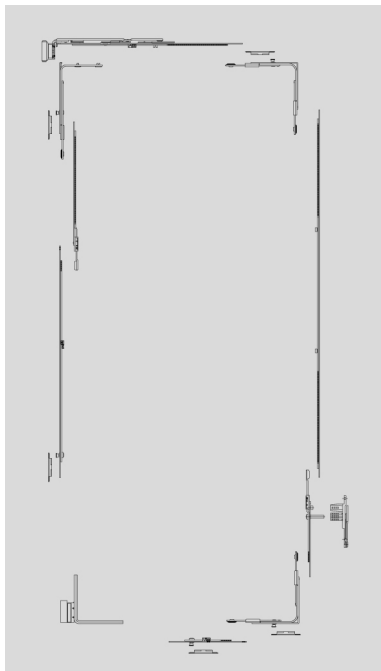

**AG 1275**

Meccanismo A/R seconda anta Dx cerniere a vista - Nodo ZTZ  
*Second leaf RH tilt-turn mechanism with visible hinges - ZTZ profiles*

RC2 (no su profili in ottone | *not on brass profiles*)

**AG 1276**

Meccanismo A/R seconda anta Sx cerniere a vista - Nodo ZTZ  
*Second leaf LH tilt-turn mechanism with visible hinges - ZTZ profiles*

RC2 (no su profili in ottone | *not on brass profiles*)

		altezza - height								
		661	861	1001	1201	1401	1601	1801	2001	2201
		860	1000	1200	1400	1600	1800	2000	2200	2400
larghezza width	601-800	A1	B1	C1	D1	E1	F1	G1	H1	I1
	801-1000	-	B2	C2	D2	E2	F2	G2	H2	I2
	1001-1200	-	-	C3	D3	E3	F3	G3	H3	I3
	1201-1400	-	-	-	D4	E4	F4	G4	H4	I4

**Limiti dimensionali | Limits**

Peso massimo anta | *Maximum leaf weight: 150 kg*  
misure cava ferramenta - H>L | *hardware measure - H>W*

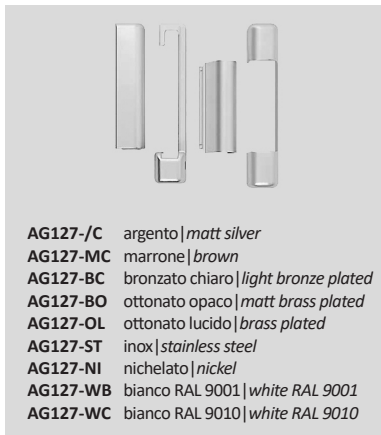

**AG 1271 ..**

Kit copertine destre in plastica  
per kit A/R AG 1271-5

*Plastic right-cover kit for  
tilt&turn for kit AG 1271-5*

**AG 1272 ..**

Kit copertine sinistre in plastica  
per kit A/R AG 1272-6

*Plastic left-cover kit for tilt&turn  
for kit AG 1272-6*

- AG127-/C argento | *matt silver*
- AG127-MC marrone | *brown*
- AG127-BC bronzato chiaro | *light bronze plated*
- AG127-BO ottonato opaco | *matt brass plated*
- AG127-OL ottonato lucido | *brass plated*
- AG127-ST inox | *stainless steel*
- AG127-NI nichelato | *nickel*
- AG127-WB bianco RAL 9001 | *white RAL 9001*
- AG127-WC bianco RAL 9010 | *white RAL 9010*

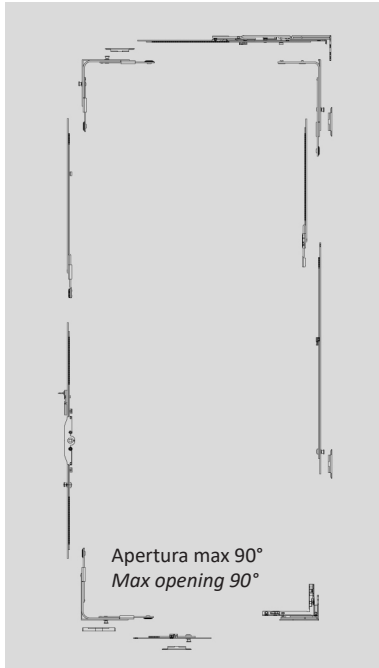

**AG 1281**

Meccanismo A/R prima anta Dx cerniere a scomparsa

*First leaf RH tilt-turn mechanism with concealed hinges*

RC2 (no su profili in ottone | *not on brass profiles*)

**AG 1282**

Meccanismo A/R prima anta Sx cerniere a scomparsa

*First leaf LH tilt-turn mechanism with concealed hinges*

RC2 (no su profili in ottone | *not on brass profiles*)

		altezza - height								
		661	861	1001	1201	1401	1601	1801	2001	2201
		860	1000	1200	1400	1600	1800	2000	2200	2400
	601-800	A1	B1	C1	D1	E1	F1	G1	H1	I1
larghezza width	801-1000	-	B2	C2	D2	E2	F2	G2	H2	I2
	1001-1200	-	-	C3	D3	E3	F3	G3	H3	I3
	1201-1400	-	-	-	D4	E4	F4	G4	H4	I4

**Limiti dimensionali | Limits**

Peso massimo anta | *Maximum leaf weight: 130 kg*

misure cava ferramenta - H>L | *hardware measure - H>W*

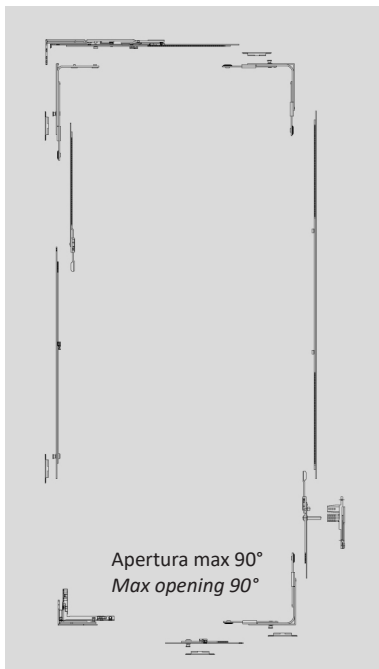

**AG 1285**

Meccanismo A/R seconda anta Dx cerniere a scomparsa - Nodo ZTZ

*Second leaf RH tilt-turn mechanism with concealed hinges - ZTZ profiles*

RC2 (no su profili in ottone | *not on brass profiles*)

**AG 1286**

Meccanismo A/R seconda anta Sx cerniere a scomparsa - Nodo ZTZ

*Second leaf LH tilt-turn mechanism with concealed hinges - ZTZ profiles*

RC2 (no su profili in ottone | *not on brass profiles*)

		altezza - height								
		661	861	1001	1201	1401	1601	1801	2001	2201
		860	1000	1200	1400	1600	1800	2000	2200	2400
	601-800	A1	B1	C1	D1	E1	F1	G1	H1	I1
larghezza width	801-1000	-	B2	C2	D2	E2	F2	G2	H2	I2
	1001-1200	-	-	C3	D3	E3	F3	G3	H3	I3
	1201-1400	-	-	-	D4	E4	F4	G4	H4	I4

**Limiti dimensionali | Limits**

Peso massimo anta | *Maximum leaf weight: 130 kg*

misure cava ferramenta - H>L | *hardware measure - H>W*

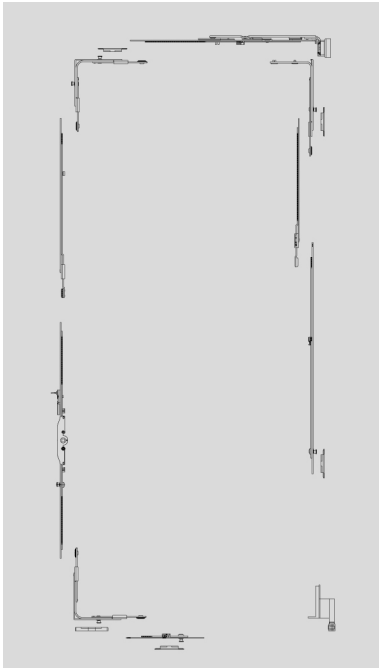

**AG 1291**

Meccanismo A/R prima anta Dx cerniere a vista in acciaio inox  
*First leaf RH tilt-turn mechanism with visible stainless steel hinges*

RC2 (no su profili in ottone | *not on brass profiles*)

**AG 1292**

Meccanismo A/R prima anta Sx cerniere a vista in acciaio inox  
*First leaf LH tilt-turn mechanism with visible stainless steel hinges*

RC2 (no su profili in ottone | *not on brass profiles*)

		altezza - height								
		661	861	1001	1201	1401	1601	1801	2001	2201
		860	1000	1200	1400	1600	1800	2000	2200	2400
	601-800	A1	B1	C1	D1	E1	F1	G1	H1	I1
larghezza width	801-1000	-	B2	C2	D2	E2	F2	G2	H2	I2
	1001-1200	-	-	C3	D3	E3	F3	G3	H3	I3
	1201-1400	-	-	-	D4	E4	F4	G4	H4	I4

**Limiti dimensionali | Limits**

Peso massimo anta | *Maximum leaf weight: 130 kg*  
misure cava ferramenta - H>L | *hardware measure - H>W*

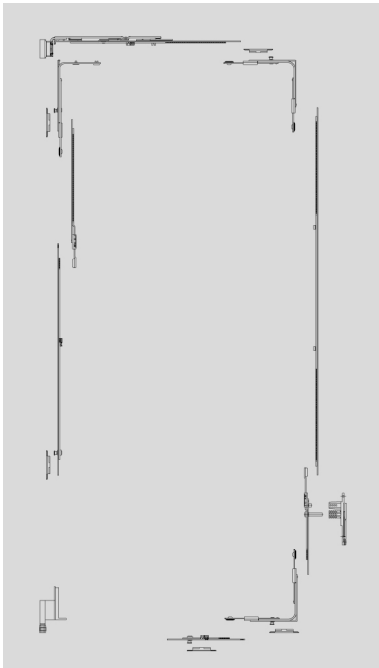

**AG 1295**

Meccanismo A/R seconda anta Dx cerniere a vista in acciaio inox - Nodo ZTZ  
*Second leaf RH tilt-turn mechanism with visible stainless steel hinges - ZTZ profiles*

RC2 (no su profili in ottone | *not on brass profiles*)

**AG 1296**

Meccanismo A/R seconda anta Sx cerniere a vista in acciaio inox - Nodo ZTZ  
*Second leaf LH tilt-turn mechanism with visible stainless steel hinges - ZTZ profiles*

RC2 (no su profili in ottone | *not on brass profiles*)

		altezza - height								
		661	861	1001	1201	1401	1601	1801	2001	2201
		860	1000	1200	1400	1600	1800	2000	2200	2400
	601-800	A1	B1	C1	D1	E1	F1	G1	H1	I1
larghezza width	801-1000	-	B2	C2	D2	E2	F2	G2	H2	I2
	1001-1200	-	-	C3	D3	E3	F3	G3	H3	I3
	1201-1400	-	-	-	D4	E4	F4	G4	H4	I4

**Limiti dimensionali | Limits**

Peso massimo anta | *Maximum leaf weight: 130 kg*  
misure cava ferramenta - H>L | *hardware measure - H>W*

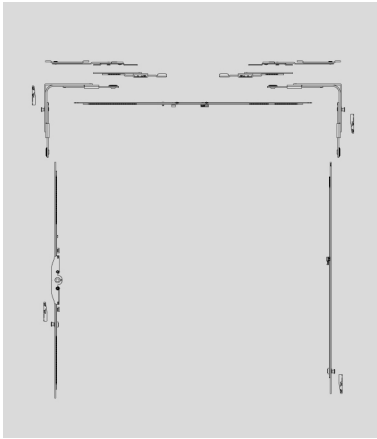

**AG 1264**

Meccanismo vasistas con cremonese su montante laterale

*Bottom-hung window mechanism with lateral cremonese bolt set EASY*

altezza - height

	<b>560</b>	<b>661</b>	<b>861</b>	<b>1201</b>	
	<b>660</b>	<b>860</b>	<b>1200</b>	<b>1600</b>	
	<b>645-910</b>	A1	B1	C1	D1
larghezza	<b>911-1110</b>	A2	B2	C2	D2
width	<b>1111-1470</b>	A3	B3	C3	D3
	<b>1471-1860</b>	A4	B4	C4	D4

**Limiti dimensionali | Limits**

Peso massimo anta | *Maximum leaf weight: 100 kg*    3 cerniere | *3 hinges*

Peso massimo anta | *Maximum leaf weight: 70 kg*    2 cerniere | *2 hinges*

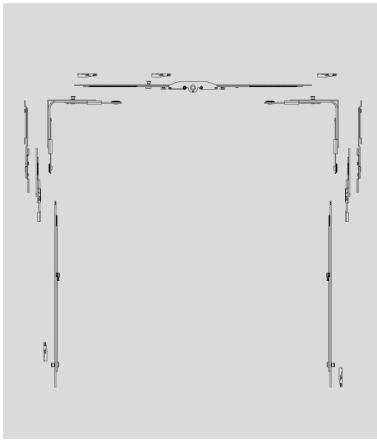

**AG 1274**

Meccanismo vasistas con cremonese su traverso superiore

*Bottom-hung window mechanism with top cremonese bolt set EASY*

altezza - height

	<b>350</b>	<b>661</b>	<b>861</b>	<b>1201</b>	
	<b>660</b>	<b>860</b>	<b>1200</b>	<b>1400</b>	
	<b>560-660</b>	A1	B1	C1	D1
larghezza	<b>661-860</b>	A2	B2	C2	D2
width	<b>861-1200</b>	A3	B3	C3	D3
	<b>1201-1600</b>	A4	B4	C4	D4

**Limiti dimensionali | Limits**

Peso massimo anta | *Maximum leaf weight: 100 kg*    3 cerniere | *3 hinges*

Peso massimo anta | *Maximum leaf weight: 70 kg*    2 cerniere | *2 hinges*

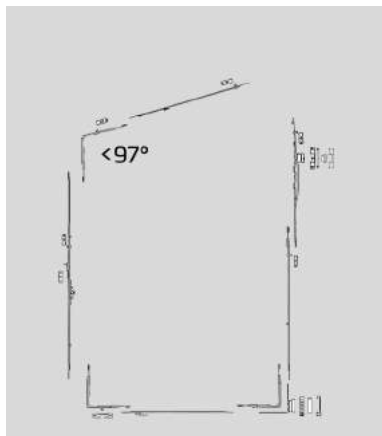
**AG 1273**

Meccanismo A/R trapezoidale ad una o due ante con cerniere a vista  
(specificare all'ordine misure cava ferramenta e mano di apertura)

*Tilt-turn mechanism with visible hinges for trapezoidal windows  
(Specify hardware slot size and the opening)*

**EASY**

**Limiti dimensionali | Limits**

Peso massimo anta | *Maximum leaf weight: 80 kg*

Larghezza massima | *Maximum width: 1200 mm*

Altezza massima | *Maximum height: 2400 mm*

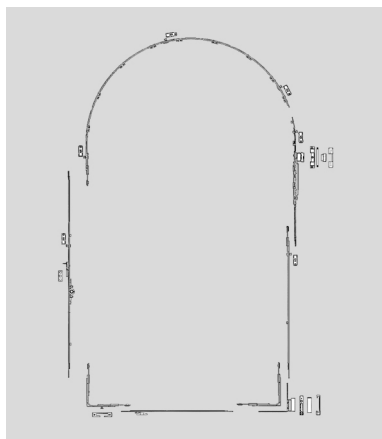
**AG 1278**

Meccanismo A/R curvo ad una o due ante con cerniere a vista  
(specificare all'ordine misure cava ferramenta e mano di apertura)

*Tilt-turn mechanism with visible hinges for arched windows  
(Specify hardware slot size and the opening)*

**EASY**

**Limiti dimensionali | Limits**

Peso massimo anta | *Maximum leaf weight: 80 kg*

Larghezza massima | *Maximum width: 1200 mm*

Altezza massima arco reale | *Maximum height arch: 1900 mm*

Altezza massima arco ribassato | *Maximum height segmental arch: 2400 mm*

**AG 1278 ..**

Kit copertine destre in plastica  
per kit A/R AG 1273-8

*Plastic right-cover kit for  
tilt&turn for kit AG 1273-8*

**AG 1279 ..**

Kit copertine sinistre in plastica  
per kit A/R AG 1273-8

*Plastic left-cover kit for tilt&turn  
for kit AG 1273-8*

AG127-/C argento | *matt silver*  
AG127-MC marrone | *brown*  
AG127-BC bronzato chiaro | *light bronze plated*  
AG127-BO ottonato opaco | *matt brass plated*  
AG127-OL ottonato lucido | *brass plated*  
AG127-ST inox | *stainless steel*  
AG127-NI nichelato | *nickel*  
AG127-WB bianco RAL 9001 | *white RAL 9001*  
AG127-WC bianco RAL 9010 | *white RAL 9010*



**AC 1001I**

Kit per giunzione angolo  
Acciaio inox

*Corner joint kit  
Stainless steel*

P.1001



**AC 1005I**

Kit per giunzione angolo  
Acciaio inox

*Corner joint kit  
Stainless steel*

P.1012



**AC 1002I**

Kit per giunzione angolo  
Acciaio inox

*Corner joint kit  
Stainless steel*

P.1002



**AC 1006I**

Kit per giunzione angolo  
Acciaio inox

*Corner joint kit  
Stainless steel*

P.1013 cassa | frame



**AC 1003I**

Kit per giunzione angolo  
Acciaio inox

*Corner joint kit  
Stainless steel*

P.1003



**AC 1007I**

Kit per giunzione angolo  
Acciaio inox

*Corner joint kit  
Stainless steel*

P.1013 anta | leaf



**AC 1004I**

Kit per giunzione angolo  
Acciaio inox

*Corner joint kit  
Stainless steel*

P.1011



**AC 1008I**

Kit per giunzione angolo  
Acciaio inox

*Corner joint kit  
Stainless steel*

P.1012-P.1013





**AC 1009I**

Kit per giunzione angolo  
Acciaio inox

*Corner joint kit  
Stainless steel  
P.1005*

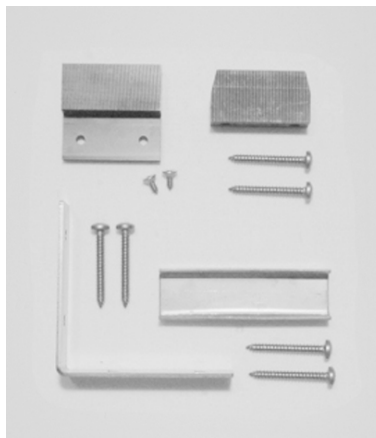

**AC 1023**

Kit per giunzione 90° profili  
maggiorati su giunto d'angolo  
Acciaio inox

*Butt joint kit on corner section  
for oversized profiles  
Stainless steel*



**AC 1013I**

Kit per giunzione angolo  
Acciaio inox

*Corner joint kit  
Stainless steel*

P.1010



**AC 1024ID**

Kit per giunzione angolo destro  
Acciaio inox

*Right corner joint kit  
Stainless steel*

P.1027-P.1012

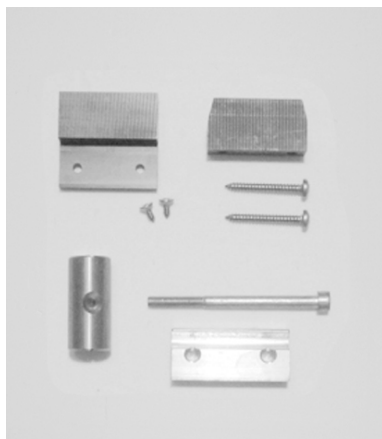

**AC 1021**

Kit per giunzione 90°  
Acciaio inox

*Butt joint kit  
Stainless steel*

P.1005  
P.1001  
P.1002



**AC 1024IS**

Kit per giunzione angolo sinistro  
Acciaio inox

*Left corner joint kit  
Stainless steel*

P.1027-P.1012

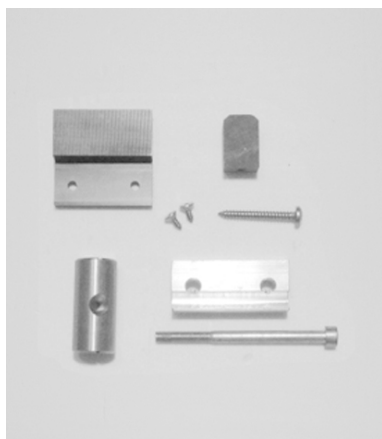

**AC 1022**

Kit per giunzione 90°  
Acciaio inox

*Butt joint kit  
Stainless steel*

P.1022



**AC 1201I**

Kit per giunzione angolo  
Acciaio inox

*Corner joint kit  
Stainless steel*

P.1201



**AC 1202I**

Kit per giunzione angolo  
Acciaio inox

*Corner joint kit  
Stainless steel*

P.1202



**AC 1211I**

Kit per giunzione 90°  
Acciaio inox

*Butt joint kit  
Stainless steel*

P.1202  
1/2 - P.1201 | P.1205

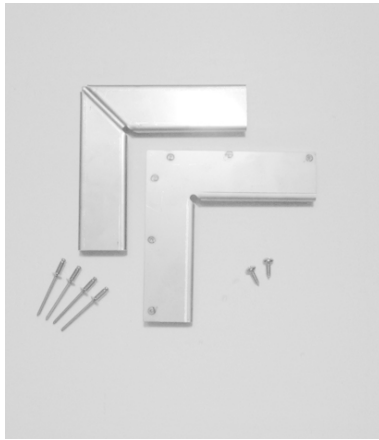

**AC 1203I**

Kit per giunzione angolo  
Acciaio inox

*Corner joint kit  
Stainless steel*

P.1203



**AC 1211IA**

Kit per giunzione 90° profili  
ridotti su giunto d'angolo  
Acciaio inox

*Butt joint kit on corner section  
for reduced profiles  
Stainless steel*



**AC 1207I**

Kit per giunzione angolo  
Acciaio inox

*Corner joint kit  
Stainless steel*

P.1233

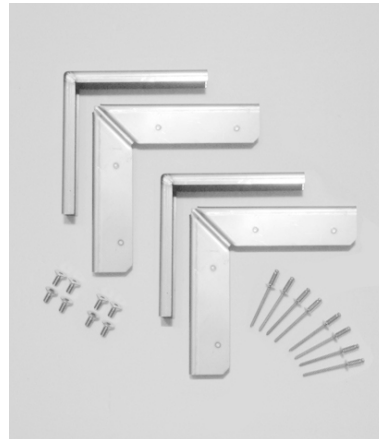

**AC 1708I**

Kit per giunzione angolo  
Acciaio inox

*Corner joint kit  
Stainless steel*

P.1724-P.1233

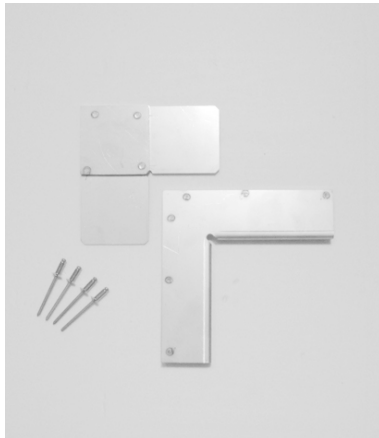

**AC 1209I**

Kit per giunzione angolo  
Acciaio inox

*Corner joint kit  
Stainless steel*

P.1205



**AC 1730I**

Kit per giunzione angolo  
Acciaio inox

*Corner joint kit  
Stainless steel*

P.1220

**AC 1731I**

Kit per giunzione angolo  
Acciaio inox

*Corner joint kit  
Stainless steel*

P.1211

**AC 1735I**

Kit per giunzione angolo  
Acciaio inox

*Corner joint kit  
Stainless steel*

P.1215

**AC 1732I**

Kit per giunzione angolo  
Acciaio inox

*Corner joint kit  
Stainless steel*

P.1212

**AC 1733I**

Kit per giunzione angolo  
Acciaio inox

*Corner joint kit  
Stainless steel*

P.1213 anta | *leaf*

**AC 1733IE**

Kit per giunzione angolo  
Acciaio inox

*Corner joint kit  
Stainless steel*

P.1213 cassa | *frame*



**ACV 065**

Quadro per doppia maniglia  
*Spindle bar for double handle*

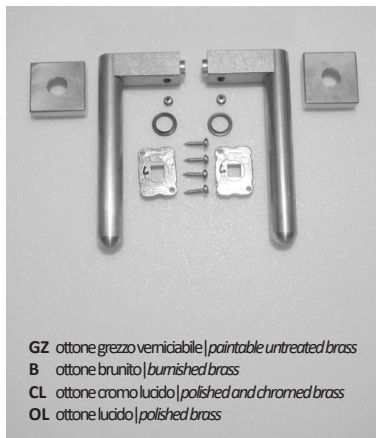

**ACV 944**

Coppia maniglie per porta  
"VITRUVIO" medium  
bocchetta quadrata  
L | tonda | sfera

*Double door handlesets  
"VITRUVIO" medium  
square escutcheon  
L | round | sphere*

GZ ottone grezzo verniciabile | paintable untreated brass  
B ottone brunito | burnished brass  
CL ottone cromo lucido | polished and chromed brass  
OL ottone lucido | polished brass



**ACV 065/R**

Quadro per maniglia singola  
*Spindle bar for single handle*

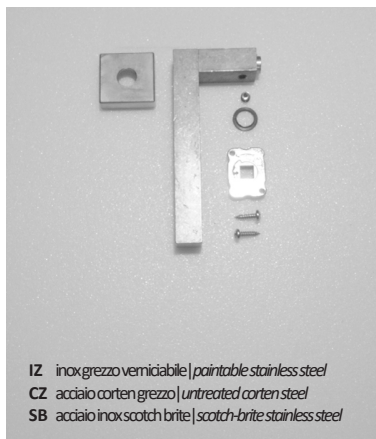

**ACV 947**

Singola maniglia per porta  
"VITRUVIO" medium  
bocchetta quadrata  
L | quadra | tronca

*Single door handleset  
"VITRUVIO" medium  
square escutcheon  
L | square | cut*

IZ inox grezzo verniciabile | paintable stainless steel  
CZ acciaio corten grezzo | untreated corten steel  
SB acciaio inox scotch brite | scotch-brite stainless steel

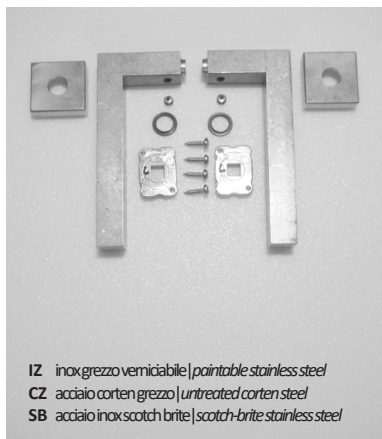

**ACV 942**

Coppia maniglie per porta  
"VITRUVIO" medium  
bocchetta quadrata  
L | quadra | tronca

*Double door handlesets  
"VITRUVIO" medium  
square escutcheon  
L | square | cut*

IZ inox grezzo verniciabile | paintable stainless steel  
CZ acciaio corten grezzo | untreated corten steel  
SB acciaio inox scotch brite | scotch-brite stainless steel



**ACV 948**

Singola maniglia per porta  
"VITRUVIO" medium  
bocchetta quadrata  
L | tonda | tronca

*Single door handleset  
"VITRUVIO" medium  
square escutcheon  
L | round | cut*

GZ ottone grezzo verniciabile | paintable untreated brass  
B ottone brunito | burnished brass  
CL ottone cromo lucido | polished and chromed brass  
OL ottone lucido | polished brass  
SB acciaio inox scotch brite | scotch-brite stainless steel

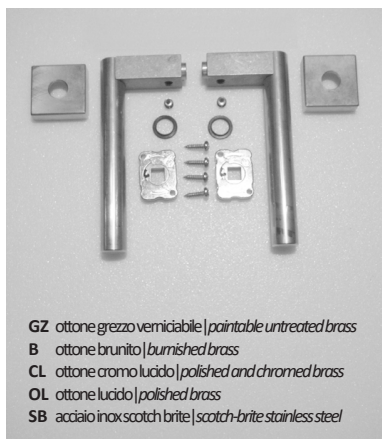

**ACV 943**

Coppia maniglie per porta  
"VITRUVIO" medium  
bocchetta quadrata  
L | tonda | tronca

*Double door handlesets  
"VITRUVIO" medium  
square escutcheon  
L | round | cut*

GZ ottone grezzo verniciabile | paintable untreated brass  
B ottone brunito | burnished brass  
CL ottone cromo lucido | polished and chromed brass  
OL ottone lucido | polished brass  
SB acciaio inox scotch brite | scotch-brite stainless steel

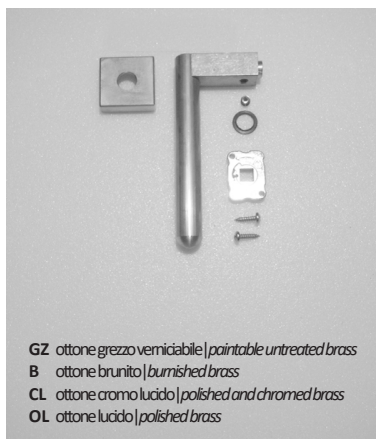

**ACV 949**

Singola maniglia per porta  
"VITRUVIO" medium  
bocchetta quadrata  
L | tonda | sfera

*Single door handleset  
"VITRUVIO" medium  
square escutcheon  
L | round | sphere*

GZ ottone grezzo verniciabile | paintable untreated brass  
B ottone brunito | burnished brass  
CL ottone cromo lucido | polished and chromed brass  
OL ottone lucido | polished brass

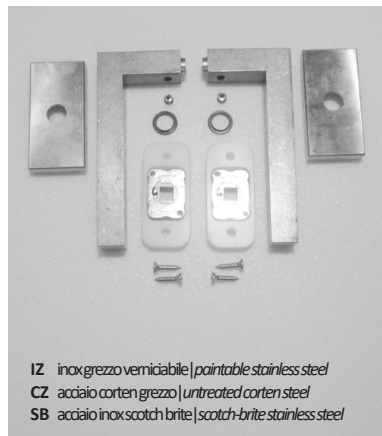
**ACV 952**

Coppia maniglie per porta  
"VITRUVIO" medium  
bocchetta rettangolare  
L | quadra | tronca

*Double door handleset  
"VITRUVIO" medium  
rectangular escutcheon  
L | square | cut*

IZ inox grezzo verniciabile | paintable stainless steel  
CZ acciaio corten grezzo | untreated corten steel  
SB acciaio inox scotch brite | scotch-brite stainless steel

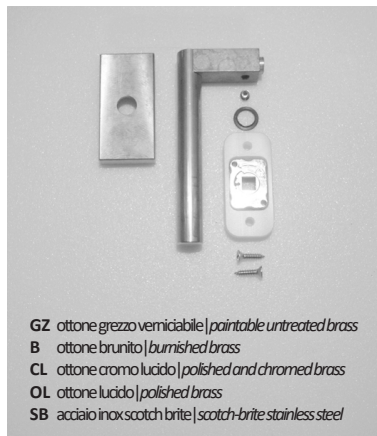
**ACV 958**

Singola maniglia per porta  
"VITRUVIO" medium  
bocchetta rettangolare  
L | tonda | tronca

*Single door handleset  
"VITRUVIO" medium  
rectangular escutcheon  
L | round | cut*

GZ ottone grezzo verniciabile | paintable untreated brass  
B ottone brunito | burnished brass  
CL ottone cromo lucido | polished and chromed brass  
OL ottone lucido | polished brass  
SB acciaio inox scotch brite | scotch-brite stainless steel

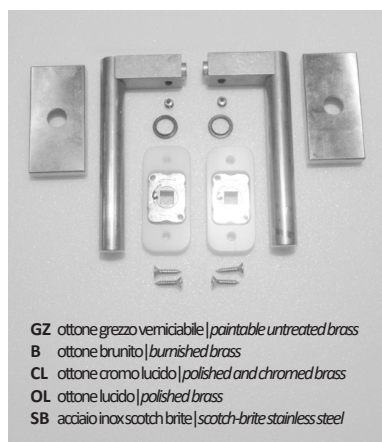
**ACV 953**

Coppia maniglie per porta  
"VITRUVIO" medium  
bocchetta rettangolare  
L | tonda | tronca

*Double door handleset  
"VITRUVIO" medium  
rectangular escutcheon  
L | round | cut*

GZ ottone grezzo verniciabile | paintable untreated brass  
B ottone brunito | burnished brass  
CL ottone cromo lucido | polished and chromed brass  
OL ottone lucido | polished brass  
SB acciaio inox scotch brite | scotch-brite stainless steel

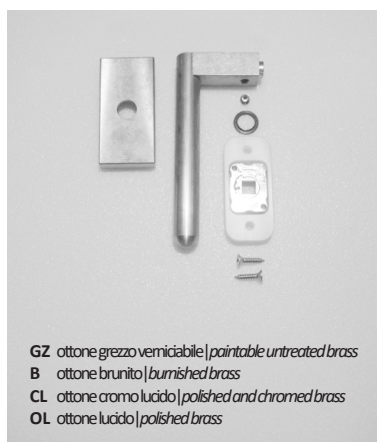
**ACV 959**

Singola maniglia per porta  
"VITRUVIO" medium  
bocchetta rettangolare  
L | tonda | sfera

*Single door handleset  
"VITRUVIO" medium  
rectangular escutcheon  
L | round | sphere*

GZ ottone grezzo verniciabile | paintable untreated brass  
B ottone brunito | burnished brass  
CL ottone cromo lucido | polished and chromed brass  
OL ottone lucido | polished brass

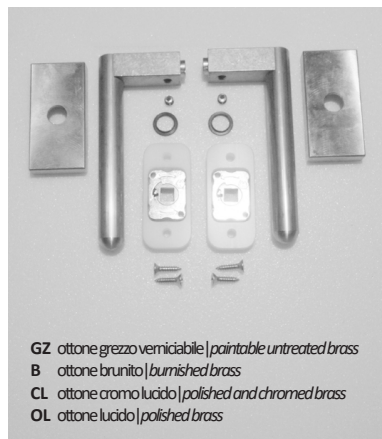
**ACV 954**

Coppia maniglie per porta  
"VITRUVIO" medium  
bocchetta rettangolare  
L | tonda | sfera

*Double door handleset  
"VITRUVIO" medium  
rectangular escutcheon  
L | round | sphere*

GZ ottone grezzo verniciabile | paintable untreated brass  
B ottone brunito | burnished brass  
CL ottone cromo lucido | polished and chromed brass  
OL ottone lucido | polished brass

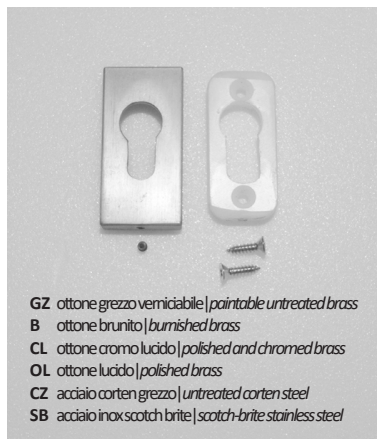
**ACV 964**

Bocchetta copri cilindro a profilo  
europeo

*Euro profile cylinder escutcheon  
plate*

GZ ottone grezzo verniciabile | paintable untreated brass  
B ottone brunito | burnished brass  
CL ottone cromo lucido | polished and chromed brass  
OL ottone lucido | polished brass  
CZ acciaio corten grezzo | untreated corten steel  
SB acciaio inox scotch brite | scotch-brite stainless steel

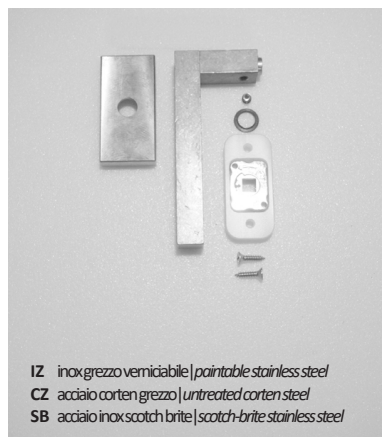
**ACV 957**

Singola maniglia per porta  
"VITRUVIO" medium  
bocchetta rettangolare  
L | quadra | tronca

*Single door handleset  
"VITRUVIO" medium  
rectangular escutcheon  
L | square | cut*

IZ inox grezzo verniciabile | paintable stainless steel  
CZ acciaio corten grezzo | untreated corten steel  
SB acciaio inox scotch brite | scotch-brite stainless steel

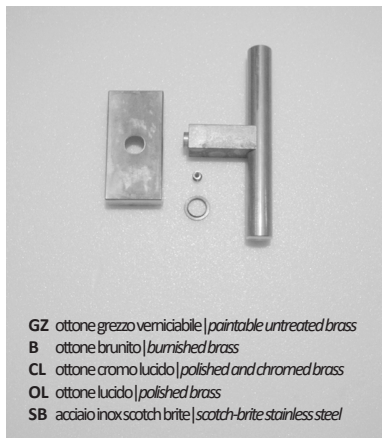

**ACV 971**

Maniglia per DK finestra "VITRUVIO" medium  
T | tonda | tronca

DK window handle  
"VITRUVIO" medium  
T | round | cut

GZ ottone grezzo verniciabile | paintable untreated brass  
B ottone brunito | burnished brass  
CL ottone cromo lucido | polished and chromed brass  
OL ottone lucido | polished brass  
SB acciaio inox scotch brite | scotch-brite stainless steel



**ACV 976**

Maniglia per DK finestra "VITRUVIO" medium  
KIDS

DK window handle  
"VITRUVIO" medium  
KIDS

GZ ottone grezzo verniciabile | paintable untreated brass  
B ottone brunito | burnished brass  
CL ottone cromo lucido | polished and chromed brass  
OL ottone lucido | polished brass

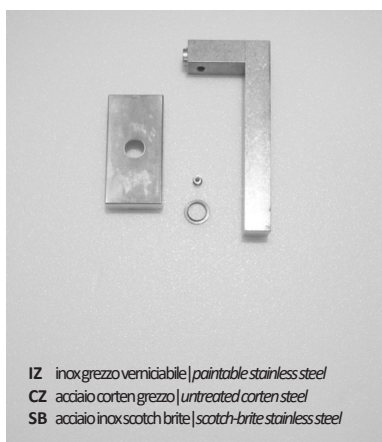

**ACV 972**

Maniglia per DK finestra "VITRUVIO" medium  
L | quadra | tronca

DK window handle  
"VITRUVIO" medium  
L | square | cut

IZ inox grezzo verniciabile | paintable stainless steel  
CZ acciaio corten grezzo | untreated corten steel  
SB acciaio inox scotch brite | scotch-brite stainless steel

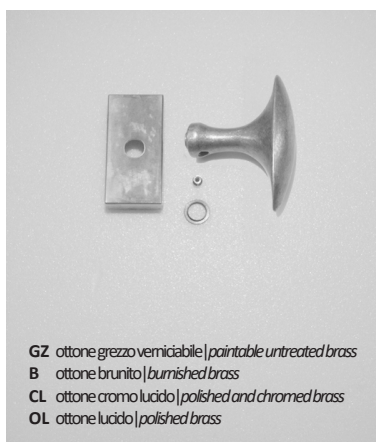

**ACV 977**

Maniglia per DK finestra "VITRUVIO" medium  
OVALE

DK window handle  
"VITRUVIO" medium  
OVALE

GZ ottone grezzo verniciabile | paintable untreated brass  
B ottone brunito | burnished brass  
CL ottone cromo lucido | polished and chromed brass  
OL ottone lucido | polished brass

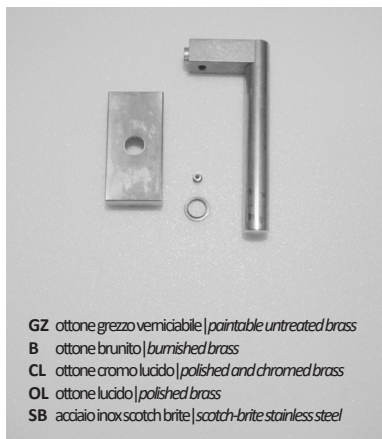

**ACV 973**

Maniglia per DK finestra "VITRUVIO" medium  
L | tonda | tronca

DK window handle  
"VITRUVIO" medium  
L | round | cut

GZ ottone grezzo verniciabile | paintable untreated brass  
B ottone brunito | burnished brass  
CL ottone cromo lucido | polished and chromed brass  
OL ottone lucido | polished brass  
SB acciaio inox scotch brite | scotch-brite stainless steel

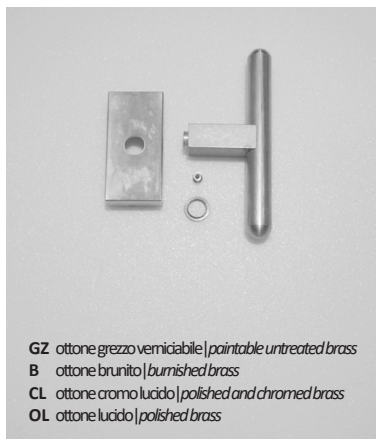

**ACV 979**

Maniglia per DK finestra "VITRUVIO" medium  
T | tonda | sfera

DK window handle  
"VITRUVIO" medium  
T | round | sphere

GZ ottone grezzo verniciabile | paintable untreated brass  
B ottone brunito | burnished brass  
CL ottone cromo lucido | polished and chromed brass  
OL ottone lucido | polished brass



**ACV 974**

Maniglia per DK finestra "VITRUVIO" medium  
L | tonda | sfera

DK window handle  
"VITRUVIO" medium  
L | round | sphere

GZ ottone grezzo verniciabile | paintable untreated brass  
B ottone brunito | burnished brass  
CL ottone cromo lucido | polished and chromed brass  
OL ottone lucido | polished brass

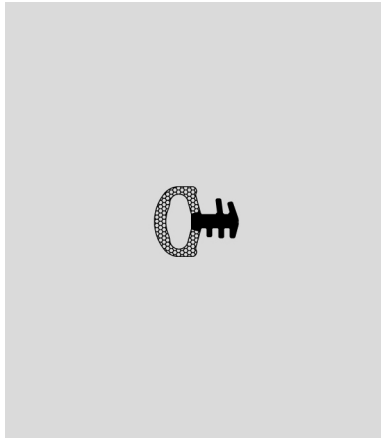

**GE 1001TT**

Guarnizione di battuta per porte e finestre

*Gasket for doors and windows*

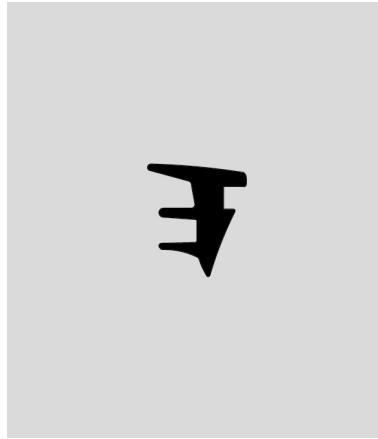

**GE 1012**

Guarnizione interna fermavetro spessore 6-8 mm

*Internal gasket for 6-8 mm thick glazing bead*

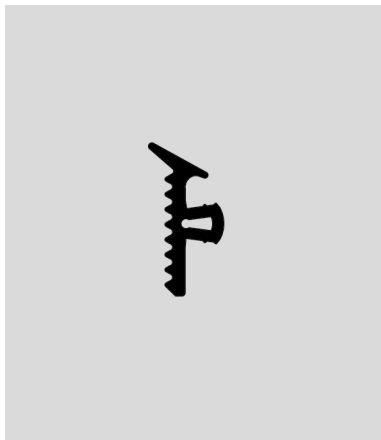

**GE 1006**

Guarnizione esterna vetro

*External gasket*

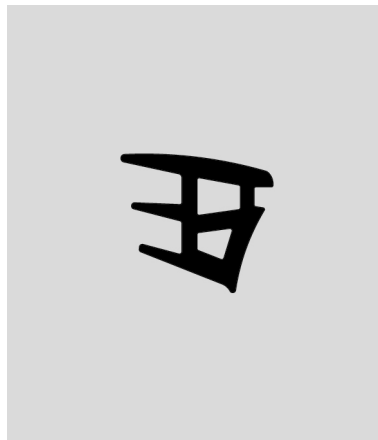

**GE 1013**

Guarnizione interna fermavetro spessore 12-16 mm

*Internal gasket for 12-16 mm thick glazing bead*

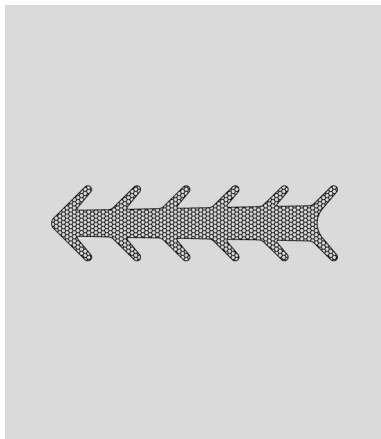

**GE 1007TT**

Guarnizione sotto vetro

*Under glass gasket*

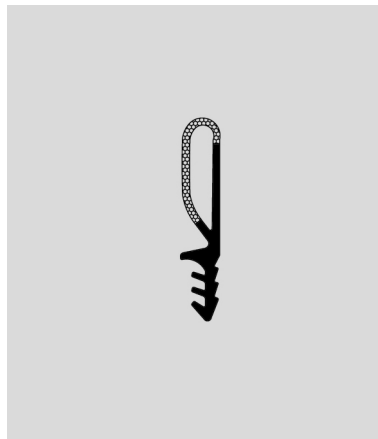

**GE 1200TT**

Guarnizione di battuta interna per finestre

*Internal gasket for windows*



**GE 1011**

Guarnizione interna fermavetro spessore 3-4 mm

*Internal gasket for 3-4 mm thick glazing bead*

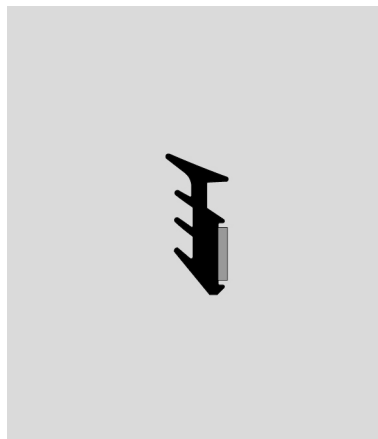

**GE 1206**

Guarnizione autoadesiva per lato esterno vetro su P.1233 | P.1724

*Self-adhesive external gasket for P.1233 | P.1724*

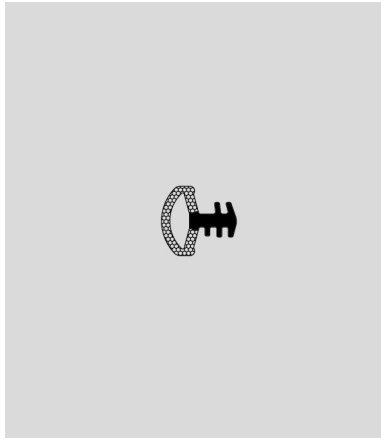

**GE 1233TT**

Guarnizione di battuta per finestre

*Gasket for windows*

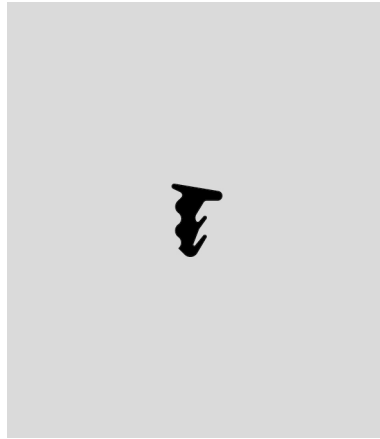

**GE 2029**

Guarnizione interna dividivetro P.2030 | P.2031 | P.2032

*Internal gasket for glass divider on P.2030 | P.2031 | P.2032*

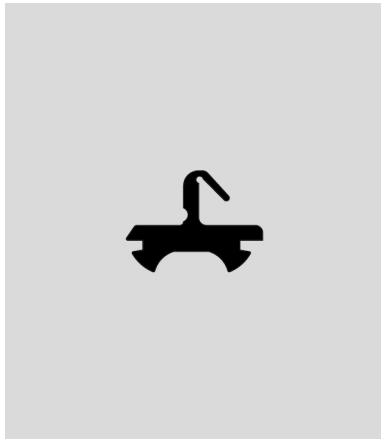

**GE 1701**

Guarnizione centrale di battuta giunto aperto finestre telaio - nodo ZTZ

*Central open-joint gasket for windows frame - ZTZ profiles*

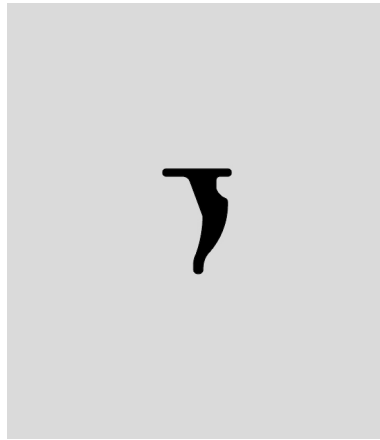

**GP 0095**

Guarnizione interna fermavetro spessore 3 mm

*Internal gasket for glazing bead, 3mm thick*

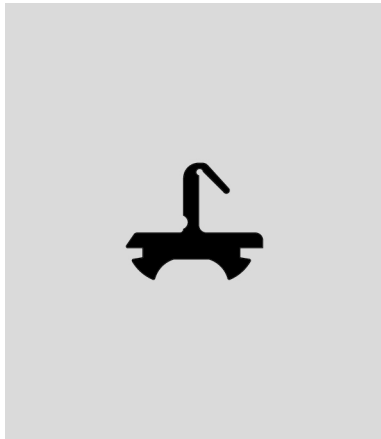

**GE 1704**

Guarnizione centrale di battuta giunto aperto finestre anta P.1724 - nodo TZ

*Central open-joint gasket for windows leaf P.1724 - TZ profiles*

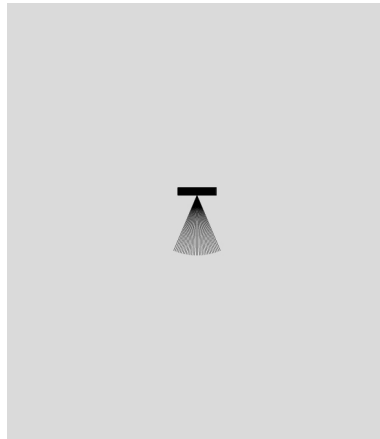

**GU 0087**

Spazzolino per porte su GU0120 H=8 mm

*Brush for doors on GU0120 H=8 mm*

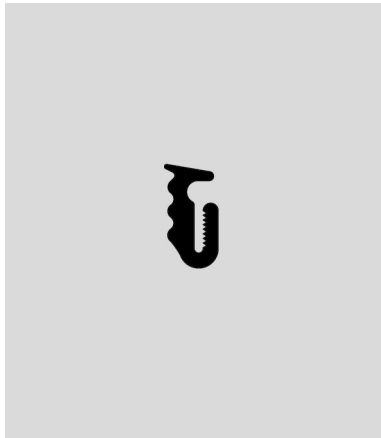

**GE 2028**

Guarnizione interna per fermavetro P.2028

*Gasket for glazing bead P.2028*

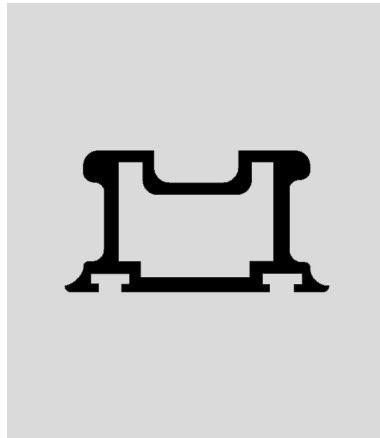

**GU 0120**

Estruso in PVC porta spazzolino per porte

*Extruded PVC brush holder for doors*



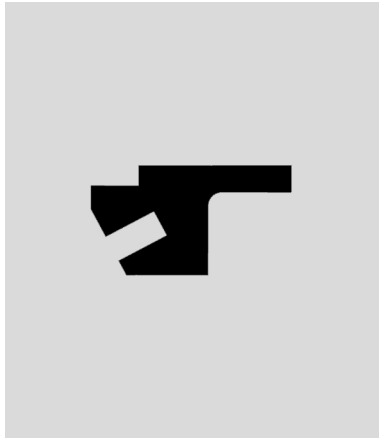

**GU 1034**

Estruso rigido in PVC per soglia porta P.1030

*Rigid extruded PVC section for P.1030 threshold*

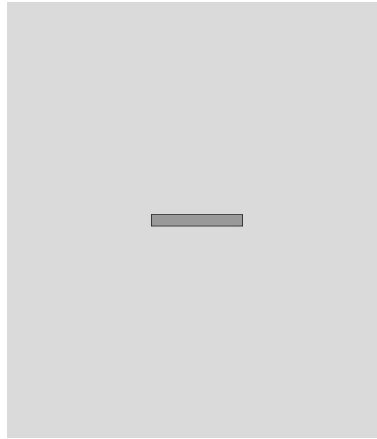

**GU 2031**

Biadesivo per dividivetro 12x1.5 mm

*Bi-adhesive tape for glass divider 12x1.5 mm*

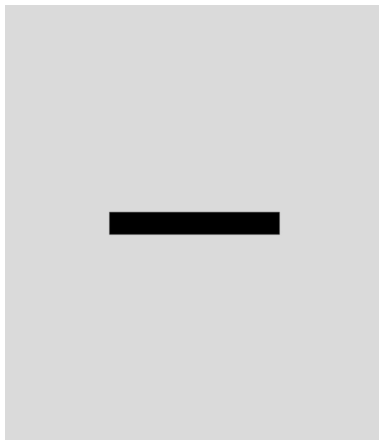

**GU 1211**

Profilo in PVC per scarico acqua aperture a sporgere

*PVC profile for water drain in awning opening*

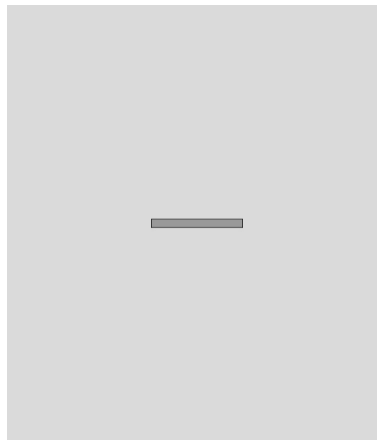

**GU 2032**

Biadesivo per dividivetro 12x1 mm

*Bi-adhesive tape for glass divider 12x1 mm*

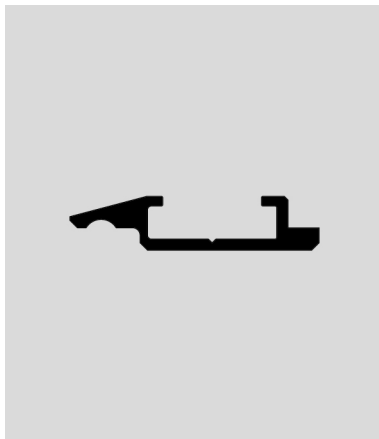

**GU 1702**

Estruso rigido in PVC per GE1701-GE1704

*Rigid extruded PVC section for GE1701-GE1704*

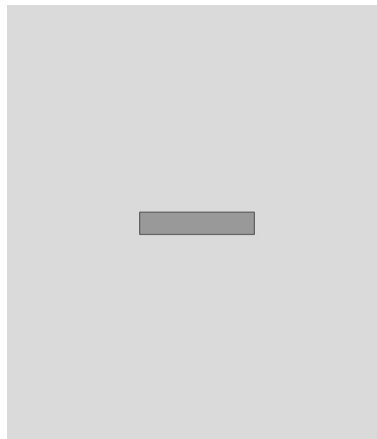

**GU 2035**

Piattina adesiva morbida per fondo giunto esterno vetro 15x3 mm

*Soft adhesive shim for external window joint 15x3 mm*

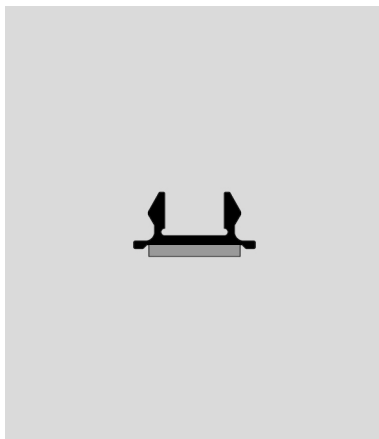

**GU 2030E**

Profilo in PVC con biadesivo per fissaggio dividivetro interno P.2030 | P.2031 | P.2032

*PVC profile with double-sided tape for fixing internal glass divider on P.2030 | P.2031 | P.2032*

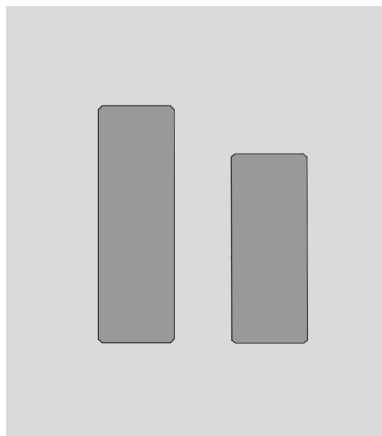

**AT 1000**

Ganasce di taglio per profili EBE 65  
*Cutting jaws for profiles EBE 65*

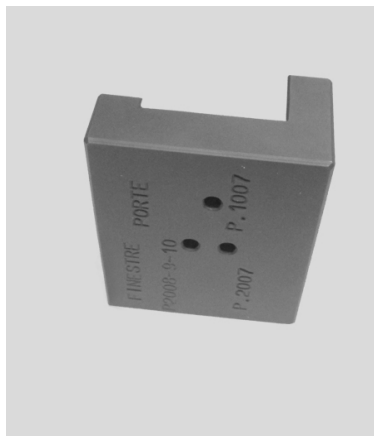

**AT 1234**

Maschera per esecuzione fori fissaggio fermavetri con boccole  
*Jig for drilling holes for glazing bead with bushings*



**AT 1001**

Maschera per esecuzione fori di fissaggio squadretta su profili maggiorati  
*Jig for drilling holes for corner plate on oversize profiles*

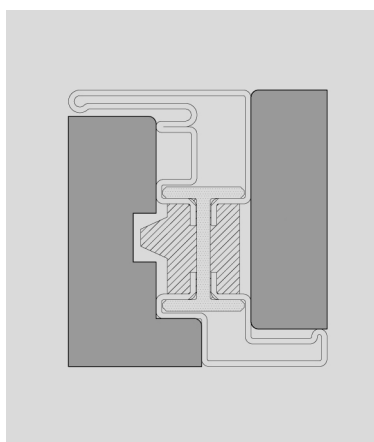

**AT 1236**

Ganasce di taglio per profilo P.1233  
*Cutting jaws for P.1233*

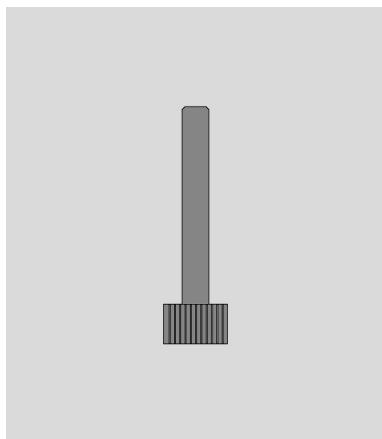

**AT 1058**

Fresa per lavorazione spacco cerniera AC1058  
*Milling cutter for hinge slot AC1058*



**AT 1242**

Maschera per esecuzione fori fissaggio cerniere A/R in acciaio inox  
*Jig for drilling holes for tilt-turn hinges in stainless steel*

*Jig for drilling holes for tilt-turn hinges in stainless steel*

AGE 291-2-5-6

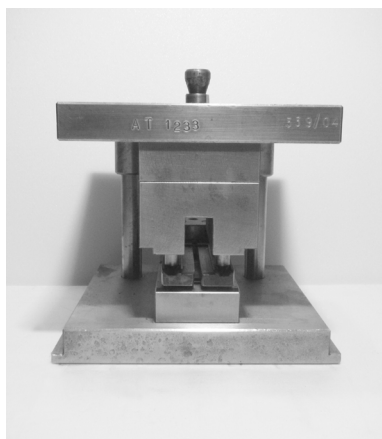

**AT 1233**

Stampo per esecuzione fori di fissaggio squadretta su profilo P.1233 | P.1724  
*Die for drilling holes for corner plate on profile P.1233 | P.1724*

*Die for drilling holes for corner plate on profile P.1233 | P.1724*

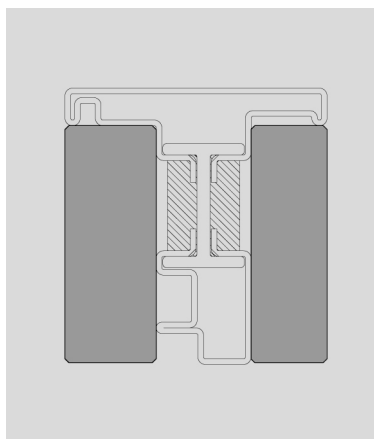

**AT 1724**

Ganasce di taglio per profilo P.1724 - P.1702  
*Cutting jaws for P.1724 - P.1702*

*Cutting jaws for P.1724 - P.1702*

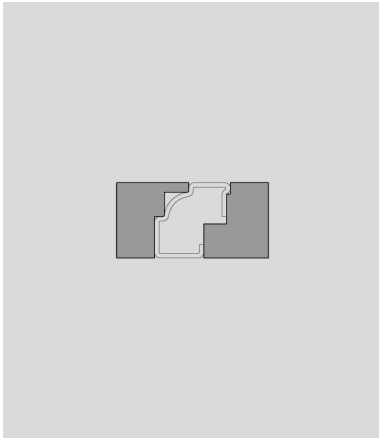

**AT 2029**

Ganasce di taglio per fermavetro  
P.2028

*Cutting jaws for glazing bead  
P.2028*

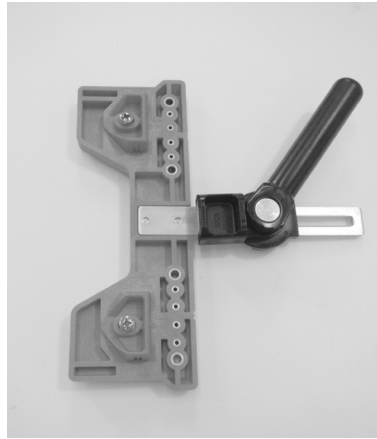

**ATG 271**

Dima per esecuzione fori  
montaggio A/R cerniere a  
sormonto

*Template for drilling holes for  
tilt-turn kit with overlap hinges*

AGE 271-2-5-6

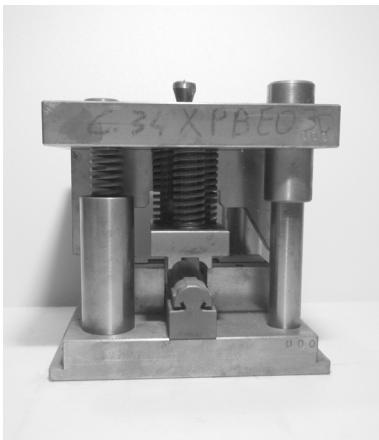

**AT 2030**

Stampo per intestatura  
P.2030

*Butt die for  
P.2030*



**ATG 281**

Kit dime per esecuzione fori  
montaggio A/R cerniere a  
scomparsa

*Template kit for drilling holes  
for tilt-turn kit with concealed  
hinges*

AGE 281-2-5-6

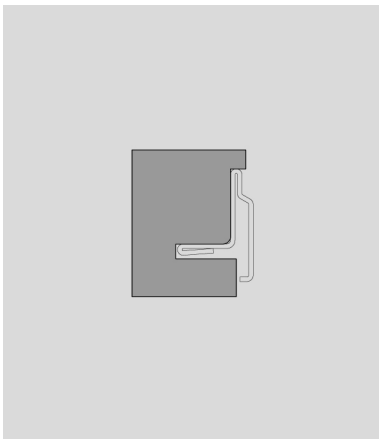

**AT 2038**

Ganasce di taglio per  
P.2038

*Cutting jaws for  
P.2038*



**ATG 303**

Maschera per esecuzione fori  
montaggio riscontri nottolini  
RC2

*Jig for drilling holes for cam  
strikes  
RC2*



**AT 2828**

Maschera per esecuzione fori  
fissaggio fermavetri con clips

*Jig for drilling holes for glazing  
bead with clips*

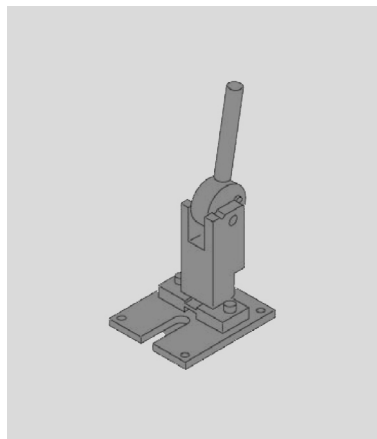

**ATG 311**

Trancia manuale

*Manual punching machine*

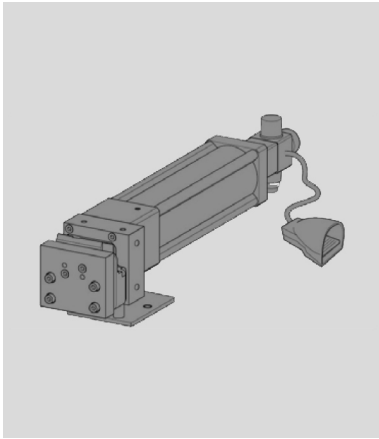
**ATG 312**

Trancia oleopneumatica

*Oil-pneumatic punching  
machine*

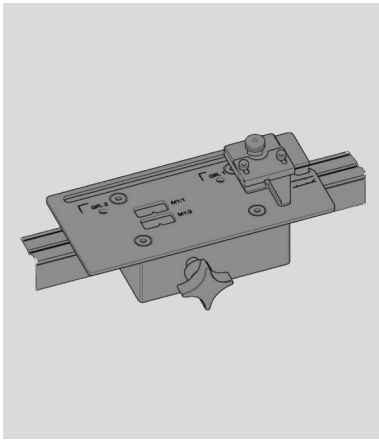
**ATG 313**

Asta millimetrata per trancia  
oleopneumatica

*Rod divided into millimetres for  
oil-pneumatic punching machine*

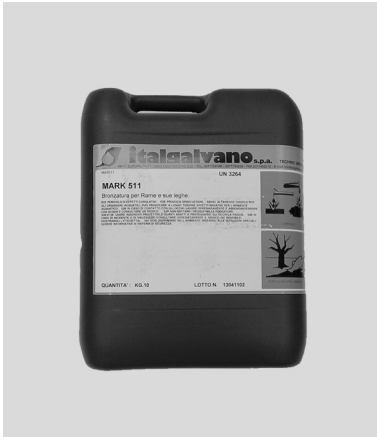
**SA 005/01**

Liquido neritore per brunitura  
1 Kg

*Burnishing liquid  
1 Kg*

**SA 005/10**

Liquido neritore per brunitura  
10 Kg

*Burnishing liquid  
10 Kg*

**SA 2002**

Spray solvente per rimozione  
collanti su superfici in acciaio  
inox

*Solvent adhesive remover spray  
for stainless steel surfaces*

**SA 1024**

Nastro adesivo protettivo per  
verniciatura  
24 mm

*Adhesive tape for painting  
24 mm*

**SA 2031**

Liquido deumidificante vetri

*Glass dehumidifying liquid*

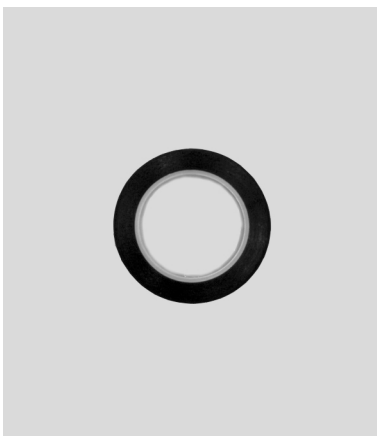
**SA 1033**

Nastro adesivo protettivo per  
verniciatura  
33 mm

*Adhesive tape for painting  
33 mm*

**SA 2032**

Primer di adesione per profili  
verniciati

*Adhesion primer for painted  
profiles*

**SA 2001**

Spray detergente antimpronta  
per superfici in acciaio inox

*Anti-fingerprint detergent spray  
for stainless steel surfaces*

**SA 2033**

Liquido di adesione per  
materiale plastico

*Adhesion liquid for plastic*



**SA 3001**

Acido per ossidazione corten

*Oxidising acid for corten*



**SL 0021**

Silicone nero per guarnizioni

*Black silicone for gaskets*

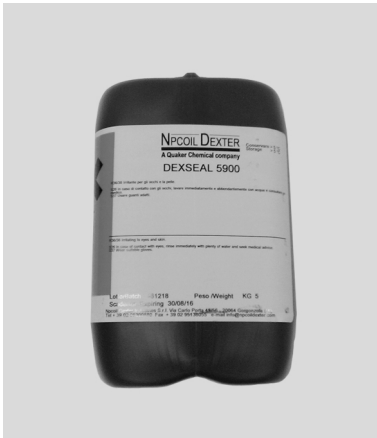

**SA 3002**

Passivante per ossidazione corten  
25 Kg

*Passivating agent for corten  
25 Kg*

**SA 3002/5**

Passivante per ossidazione corten  
5 Kg

*Passivating agent for corten  
5 Kg*



**SL 0100**

Silicone strutturale grigio  
per vetri  
RC2

*Gray structural silicone  
for glass  
RC2*



**SA 3003**

Cera d'api per finitura corten

*Beeswax for Corten finishing*



**SL 0019**

Sigillante a freddo per giunzione  
angoli e traversi

*Cold sealant for corner and  
transom joints*

1 kg

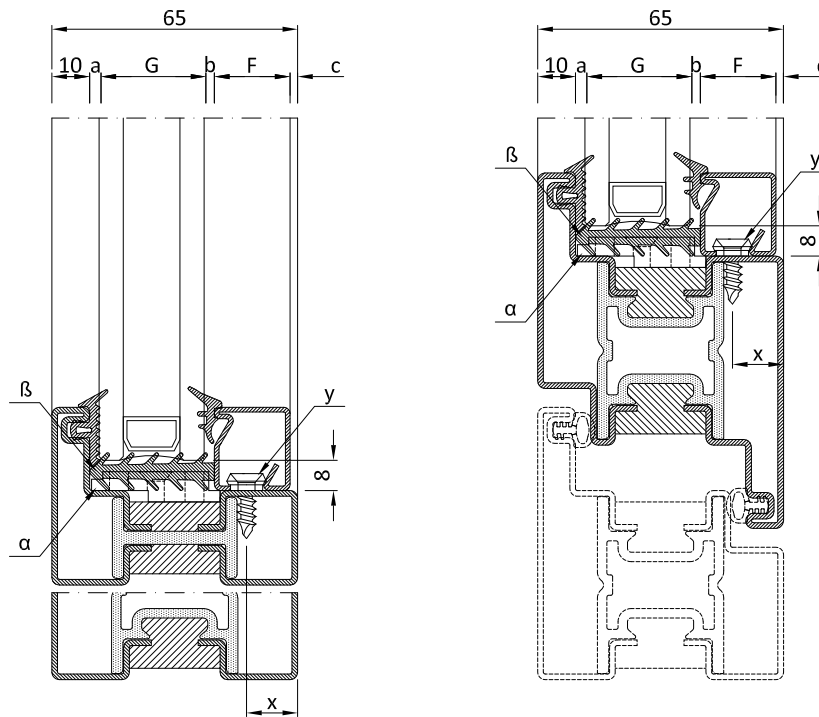

F	G	Guarnizioni - gaskets										
fermavetro glazing bead	range vetro glass range	GE1006 3 mm 	GP0095 2 / 3 mm 	GE1011 3 / 4 mm 	GE1012 6 / 8 mm 	GE1013 12 / 16 mm 	asse fissaggio viti fermavetro securing axis for screws for the glazing beads	rientro fermavetro glazing beads gap	boccole e viti fissaggio fermavetro Bushings and screws for glazing bead fixing	spessore per vetro glass shim	guarnizione sotto vetro under glass gasket	
Code		a	b	b	b	b	x	c	y	α	β	
 P.2007	18 - 34	3	31	30	26	18	9.5	2	CV5001(i) CV5012(i)	AC1020M	GE1007TT	
			-	-	-	-						
33	32		28	20	7.5	0						
-	-		-	-								
34	33		30	24								
 P.1007	18 - 30		27	26	22	18 min	13.5	2	CV5001(i) CV5012(i)	AC1020M	GE1007TT	
		-	-	-	-							
28	27	24	18 min	11.5	0							
-	-	-	-									
29	28	24	20									
30	29	26										
 P.2008	18 - 25	-	-	-	-	-	-	CV5001(i) CV5012(i)	AC1020R	GE1007TT		
		24	23	19	-							
-	-	-	-	-	-	16	0					
25	24	21										

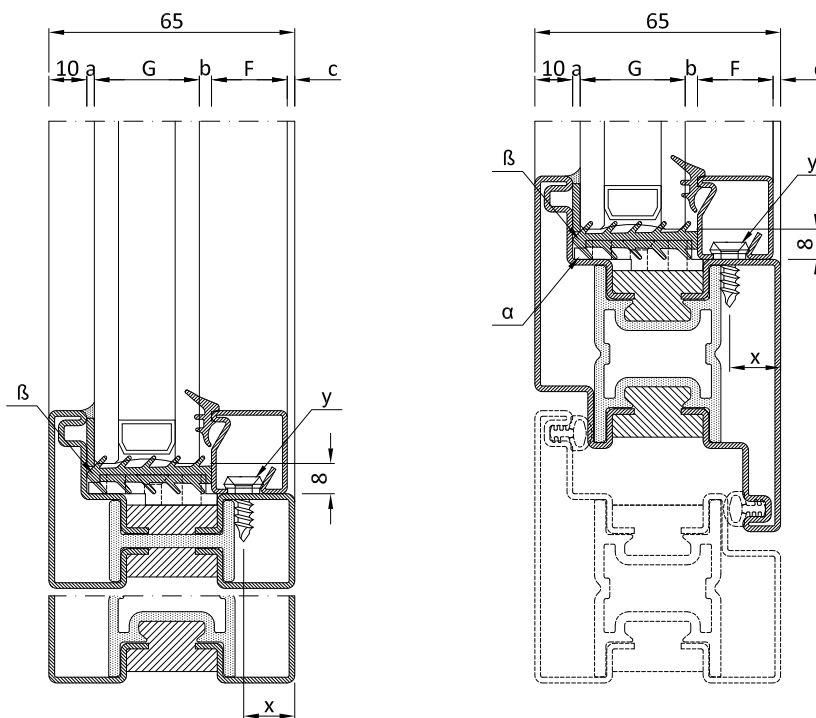

F	G	Guarnizioni - gaskets									
fermavetro glazing bead	range vetro glass range	GU2035 2 mm  + sigillatura + sealing	GP0095 2 / 3 mm 	GE1011 3 / 4 mm 	GE1012 6 / 8 mm 	GE1013 12 / 16 mm 	asse fissaggio viti fermavetro securing axis for screws for the glazing beads	rientro fermavetro glazing beads gap	boccole e viti fissaggio fermavetro Bushings and screws for glazing bead fixing	spessore per vetro glass shim	guarnizione sotto vetro under glass gasket
Code		a	b	b	b	b	x	c	y	α	β
 P.2007	19 - 35	2	32	31	27	19	9.5	2	CV5001(i) CV5012(i)	AC1020M	GE1007TT
			-	-	-	-					
 P.1007	18 - 31	2	34	33	29	21	7.5	0	CV5001(i) CV5012(i)	AC1020M	GE1007TT
			-	-	-	-					
 P.2008	20 - 26	2	28	27	23	18 min	13.5	2	CV5001(i) CV5012(i)	AC1020M	GE1007TT
			-	-	-	-					
 P.2008	20 - 26	2	29	28	25	18 min	11.5	0	CV5001(i) CV5012(i)	AC1020M	GE1007TT
			-	-	-	-					
 P.2008	20 - 26	2	30	29	25	18 min	16	0	CV5001(i) CV5012(i)	AC1020R	GE1007TT
			-	-	-	-					
 P.2008	20 - 26	2	31	30	27	21	-	-	CV5001(i) CV5012(i)	AC1020R	GE1007TT
			-	-	-	-					
 P.2008	20 - 26	2	25	24	20	-	-	-	CV5001(i) CV5012(i)	AC1020R	GE1007TT
			-	-	-	-					
 P.2008	20 - 26	2	26	25	22	-	-	-	CV5001(i) CV5012(i)	AC1020R	GE1007TT
			-	-	-	-					



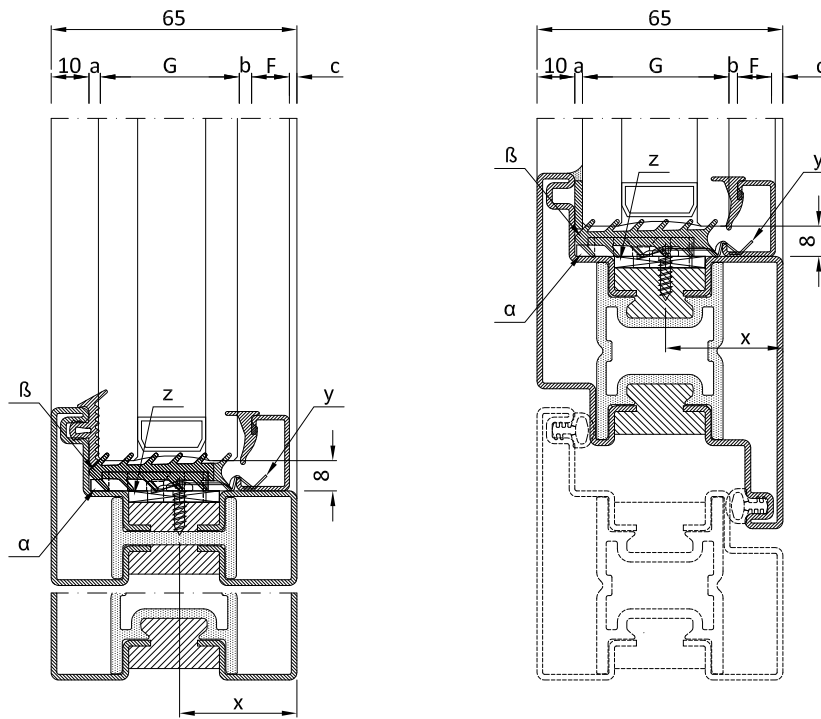

F		Guarnizioni - gaskets		G						
fermavetro glazing bead	range vetro glass range	GE1006 3 mm 	GP0095 3 mm 	spessore vetro glass thickness	asse fissaggio viti fermavetro securing axis for screws for the glazing beads	rientro fermavetro glazing beads gap	clips fissaggio fermavetro securing clips for glazing beads	spessore di compensazione * Shim *	spessore per vetro glass shim	guarnizione sotto vetro under glass gasket
Code		a	b	mm.	x	c	y	z	α	β
 P.2015	37 - 39	3	3	37	31	2	AC2608	3 mm.	AC1020M	GE1007TT
				39	29	0				

F		Guarnizioni - gaskets		G						
fermavetro glazing bead	range vetro glass range	GU2035 2 mm  + sigillatura + sealing	GP0095 3 mm 	spessore vetro glass thickness	asse fissaggio viti fermavetro securing axis for screws for the glazing beads	rientro fermavetro glazing beads gap	clips fissaggio fermavetro securing clips for glazing beads	spessore di compensazione * Shim *	spessore per vetro glass shim	guarnizione sotto vetro under glass gasket
Code		a	b	mm.	x	c	y	z	α	β
 P.2015	38 - 40	2	3	38	31	2	AC2608	3 mm.	AC1020M	GE1007TT
				40	29	0				

\*non fornito  
\*not included

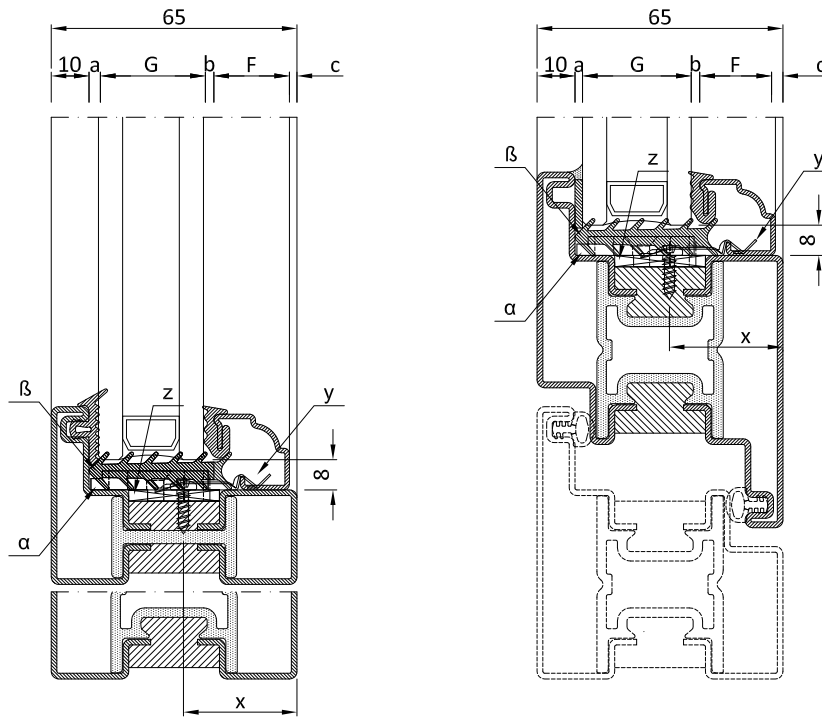

F		Guarnizioni - gaskets		G						
fermavetro glazing bead	range vetro glass range	GE1006 3 mm 	GE2028 2.5 mm 	spessore vetro glass thickness	asse fissaggio viti fermavetro securing axis for screws for the glazing beads	rientro fermavetro glazing beads gap	clips fissaggio fermavetro securing clips for glazing beads	spessore di compensazione * Shim *	spessore per vetro glass shim	guarnizione sotto vetro under glass gasket
Code		a	b	mm.	x	c	y	z	α	β
 P.2028	24 - 30	3	2.5	24	34	6	AC2608	3 mm.	AC1020M	GE1007TT
				26	32	4				
				28	30	2				
				30	28	0				

F		Guarnizioni - gaskets		G						
fermavetro glazing bead	range vetro glass range	GU2035 2 mm 	GE2028 2.5 mm 	spessore vetro glass thickness	asse fissaggio viti fermavetro securing axis for screws for the glazing beads	rientro fermavetro glazing beads gap	clips fissaggio fermavetro securing clips for glazing beads	spessore di compensazione * Shim *	spessore per vetro glass shim	guarnizione sotto vetro under glass gasket
Code		a	b	mm.	x	c	y	z	α	β
 P.2028	25 - 31	2	2.5	25	34	6	AC2608	3 mm.	AC1020M	GE1007TT
				27	32	4				
				29	30	2				
				31	28	0				

\*non fornito  
\*not included

Taglio a 45° dei fermavetri effettuabile utilizzando la ganascia AT2029  
45° cutting of the glazing beads done using the cutting jaw AT2029



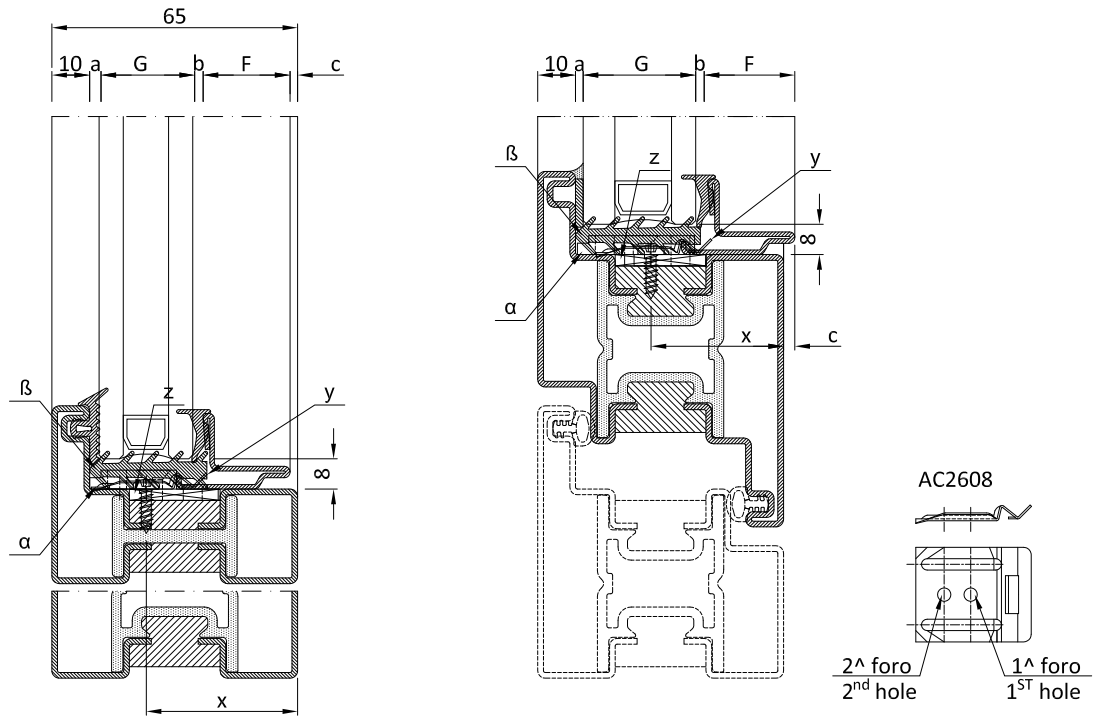

F		Guarnizioni - gaskets		G						
fermavetro glazing bead	range vetro glass range	GE1006 3 mm 	GP0095 3 mm 	spessore vetro glass thickness	asse fissaggio viti fermavetro securing axis for screws for the glazing beads	rientro fermavetro glazing beads gap	clips fissaggio fermavetro securing clips for glazing beads	spessore di compensazione * Shim *	spessore per vetro glass shim	guarnizione sotto vetro under glass gasket
Code		a	b	mm.	x	c	y	z	α	β
 P.2038	24 - 30	3	3	24	40**	2	AC2608	3 mm.	AC1020R	GE1007TT
				26	38**	0				
				28	36**	-2				
				30	34**	-4				

F		Guarnizioni - gaskets		G						
fermavetro glazing bead	range vetro glass range	GU2035 2 mm  + sigillatura + sealing	GP0095 3 mm 	spessore vetro glass thickness	asse fissaggio viti fermavetro securing axis for screws for the glazing beads	rientro fermavetro glazing beads gap	clips fissaggio fermavetro securing clips for glazing beads	spessore di compensazione * Shim *	spessore per vetro glass shim	guarnizione sotto vetro under glass gasket
Code		a	b	mm.	x	c	y	z	α	β
 P.2038	25 - 31	2	3	25	40**	2	AC2608	3 mm.	AC1020R	GE1007TT
				27	38**	0				
				29	36**	-2				
				31	34**	-4				

\*non fornito  
\*not included



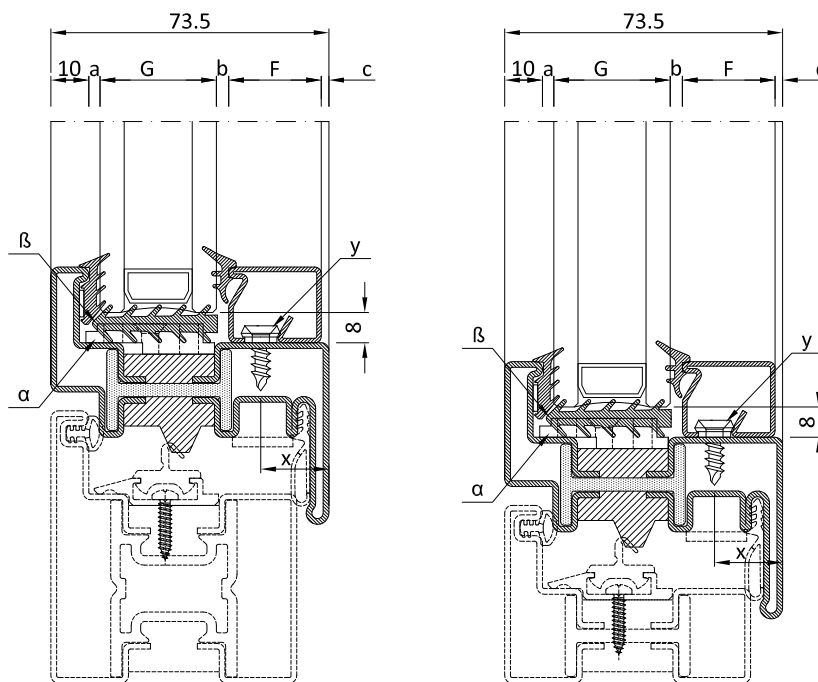

\*\* fissare tramite il primo foro della clip  
\*\* screw in the upper hole of the clip

Taglio a 45° dei fermavetri effettuabile utilizzando la ganascia AT2038  
45° cutting of the glazing beads done using the cutting jaw AT2038

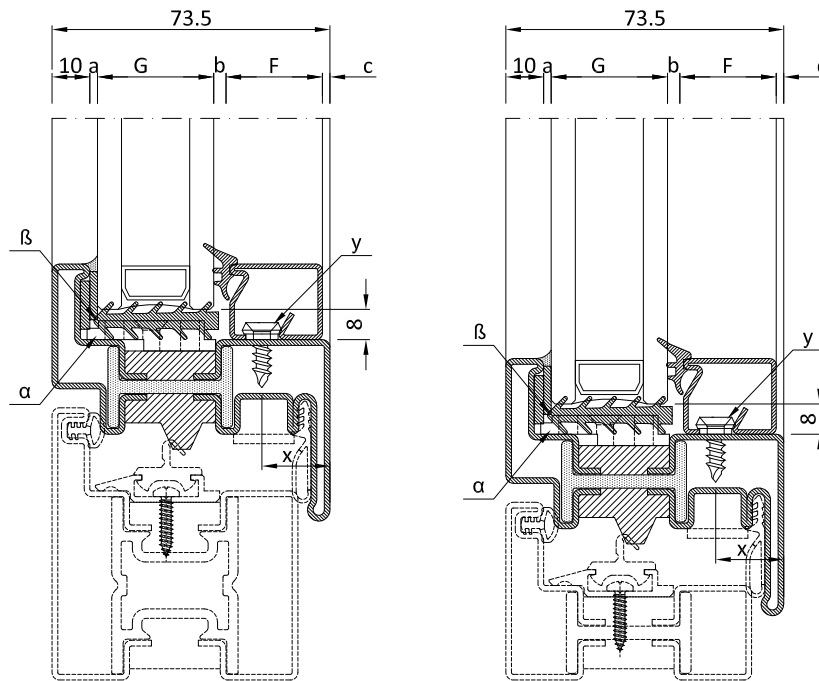

F	G	Guarnizioni - gaskets									
fermavetro glazing bead	range vetro glass range	GE1206 3 mm	GP0095 2 / 3 mm	GE1011 3 / 4 mm	GE1012 6 / 8 mm	GE1013 12 / 16 mm	asse fissaggio viti fermavetro securing axis for screws for the glazing beads	rientro fermavetro glazing beads gap	boccole e viti fissaggio fermavetro Bushings and screws for glazing bead fixing	spessore per vetro glass shim	guarnizione sotto vetro under glass gasket
Code		a	b	b	b	b	x	c	y	α	β
 P.2007	27 - 43	3	40	39	35	27	9.5	2	CV5001(i) CV5012(i)	AC1020M	GE1007TT
			-	-	-	-					
			41	40	37	31	7.5	0			
			-	-	-	-					
42	41		37	29	13.5	2					
-	-		-	-							
43	42		39	33	11.5	0					
-	-		-	-							
 P.1007	23 - 39	36	35	31	23	18	2	CV5001(i) CV5012(i)	AC1020M	GE1007TT	
		-	-	-	-						
		37	36	33	27	16	0				
		-	-	-	-						
38	37	33	25	18	2						
-	-	-	-								
39	38	35	29	16	0						
-	-	-	-								
 P.2008	20 - 34	31	30	26	18	18	2	CV5001(i) CV5012(i)	AC1020M	GE1007TT	
		-	-	-	-						
		32	31	28	22	16	0				
		-	-	-	-						
33	32	28	20	18	2						
-	-	-	-								
34	33	30	24	16	0						
-	-	-	-								
 P.2009	18 - 24	21	20	18 min.	-	18	2	CV5001(i) CV5012(i)	AC1020R	GE1007TT	
		-	-	-	-						
		22	21	18	-	16	0				
		-	-	-	-						
23	22	18	-	16	0						
-	-	-	-								
24	23	20	-	16	0						
-	-	-	-								

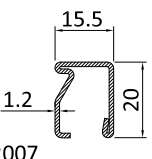
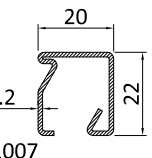
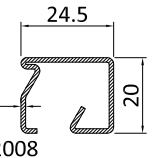
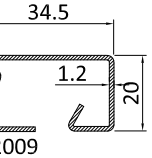

F	G	Guarnizioni - gaskets									
fermavetro glazing bead	range vetro glass range	GU2035 2 mm  + sigillatura + sealing	GP0095 2 / 3 mm 	GE1011 3 / 4 mm 	GE1012 6 / 8 mm 	GE1013 12 / 16 mm 	asse fissaggio viti fermavetro securing axis for screws for the glazing beads	rientro fermavetro glazing beads gap	boccole e viti fissaggio fermavetro Bushings and screws for glazing bead fixing	spessore per vetro glass shim	guarnizione sotto vetro under glass gasket
Code		a	b	b	b	b	x	c	y	α	β
 P.2007	28 - 44	2	41	40	36	28	9.5	2	CV5001(i) CV5012(i)	AC1020M	GE1007TT
			-	-	-	-					
			42	41	38	32	7.5	0			
			-	-	-	-					
43	42		38	30	13.5	2					
-	-		-	-							
44	43		40	34	11.5	0					
-	-		-	-							
 P.1007	24 - 40	37	36	32	24	18	2	CV5001(i) CV5012(i)	AC1020M	GE1007TT	
		-	-	-	-						
		38	37	34	28	16	0				
		-	-	-	-						
39	38	34	26	18	2						
-	-	-	-								
40	39	36	30	16	0						
-	-	-	-								
 P.2008	19 - 35	32	31	27	19	18	2	CV5001(i) CV5012(i)	AC1020M	GE1007TT	
		-	-	-	-						
		33	32	29	23	16	0				
		-	-	-	-						
34	33	29	21	18	2						
-	-	-	-								
35	34	31	25	16	0						
-	-	-	-								
 P.2009	18 - 25	22	21	18 min.	-	18	2	CV5001(i) CV5012(i)	AC1020R	GE1007TT	
		-	-	-	-						
		23	22	19	-	16	0				
		-	-	-	-						
24	23	19	-	16	0						
-	-	-	-								
25	24	21	-	16	0						
-	-	-	-								

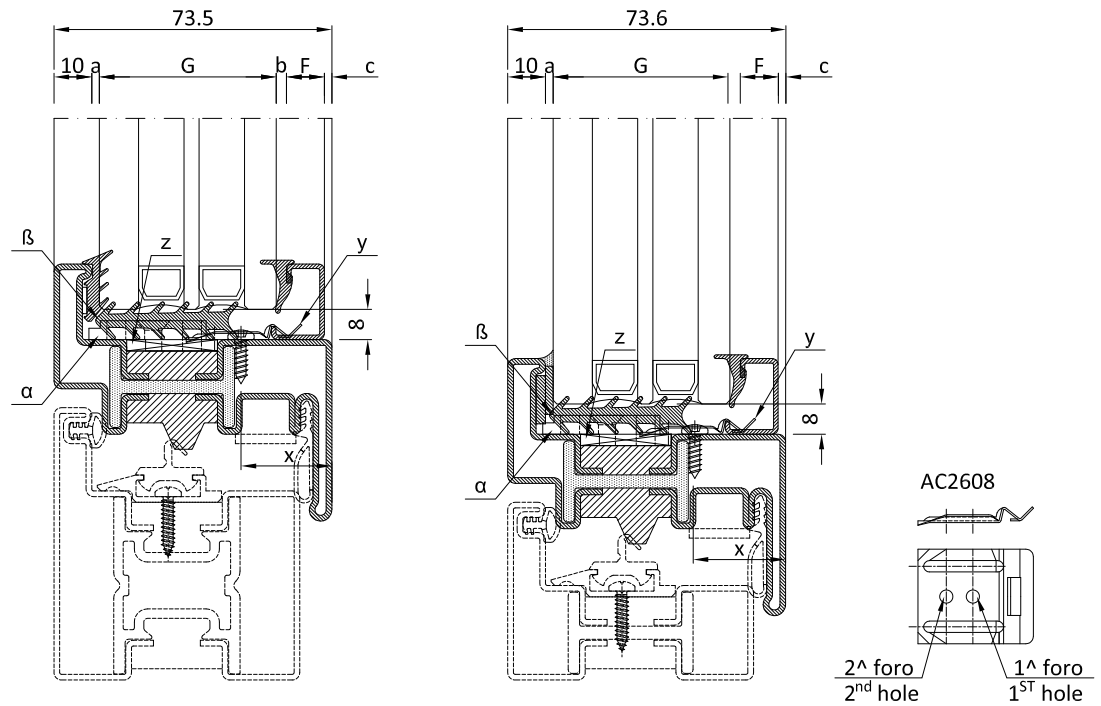

F		Guarnizioni - gaskets		G						
fermavetro glazing bead	range vetro glass range	GE1206 3 mm 	GP0095 3 mm 	spessore vetro glass thickness	asse fissaggio viti fermavetro securing axis for screws for the glazing beads	rientro fermavetro glazing beads gap	clips fissaggio fermavetro securing clips for glazing beads	spessore di compensazione * Shim *	spessore per vetro glass shim	guarnizione sotto vetro under glass gasket
Code		a	b	mm.	x	c	y	z	α	β
 P.2015	43	3	3	43	26**	2	AC2608	3 mm.	AC1020M	GE1007TT
	45			45	24**	0				

F		Guarnizioni - gaskets		G						
fermavetro glazing bead	range vetro glass range	GU2035 2 mm  + sigillatura + sealing	GP0095 3 mm 	spessore vetro glass thickness	asse fissaggio viti fermavetro securing axis for screws for the glazing beads	rientro fermavetro glazing beads gap	clips fissaggio fermavetro securing clips for glazing beads	spessore di compensazione * Shim *	spessore per vetro glass shim	guarnizione sotto vetro under glass gasket
Code		a	b	mm.	x	c	y	z	α	β
 P.2015	44	2	3	44	26**	2	AC2608	3 mm.	AC1020M	GE1007TT
	46			46	24**	0				

\*non fornito  
\*not included

\*\* fissare tramite il primo foro della clip  
\*\* screw in the upper hole of the clip

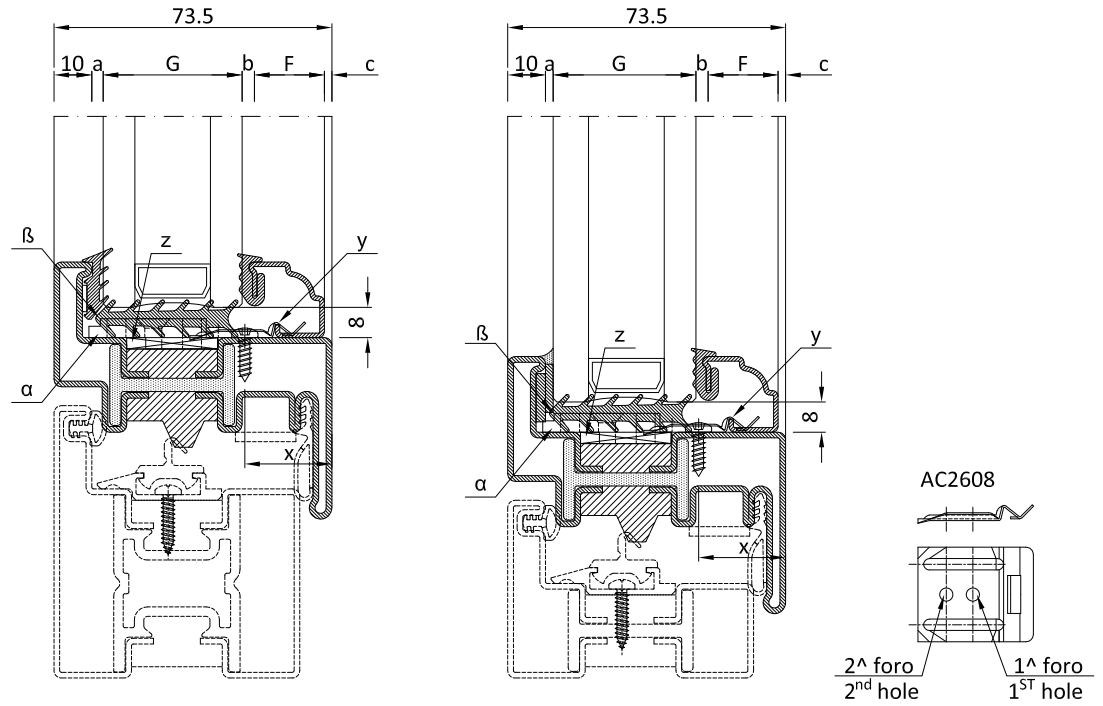

F		Guarnizioni - gaskets		G						
fermavetro glazing bead	range vetro glass range	GE1206 3 mm 	GE2028 2.5 mm 	spessore vetro glass thickness	asse fissaggio viti fermavetro securing axis for screws for the glazing beads	rientro fermavetro glazing beads gap	clips fissaggio fermavetro securing clips for glazing beads	spessore di compensazione * Shim *	spessore per vetro glass shim	guarnizione sotto vetro under glass gasket
Code		a	b	mm.	x	c	y	z	α	β
 P.2028	32 - 38	3	2.5	32	34	6	AC2608	3 mm.	AC1020M	GE1007TT
				34	25**	4				
				36	23**	2				
				38	21**	0				

F		Guarnizioni - gaskets		G						
fermavetro glazing bead	range vetro glass range	GU2035 2 mm  + sigillatura + sealing	GE2028 2.5 mm 	spessore vetro glass thickness	asse fissaggio viti fermavetro securing axis for screws for the glazing beads	rientro fermavetro glazing beads gap	clips fissaggio fermavetro securing clips for glazing beads	spessore di compensazione * Shim *	spessore per vetro glass shim	guarnizione sotto vetro under glass gasket
Code		a	b	mm.	x	c	y	z	α	β
 P.2028	33 - 39	2	2.5	33	34	6	AC2608	3 mm.	AC1020M	GE1007TT
				35	25**	4				
				37	23**	2				
				39	21**	0				

\*non fornito  
\*not included

\*\* fissare tramite il primo foro della clip  
\*\* screw in the upper hole of the clip

Taglio a 45° dei fermavetri effettuabile utilizzando la ganascia AT2029  
45° cutting of the glazing beads done using the cutting jaw AT2029



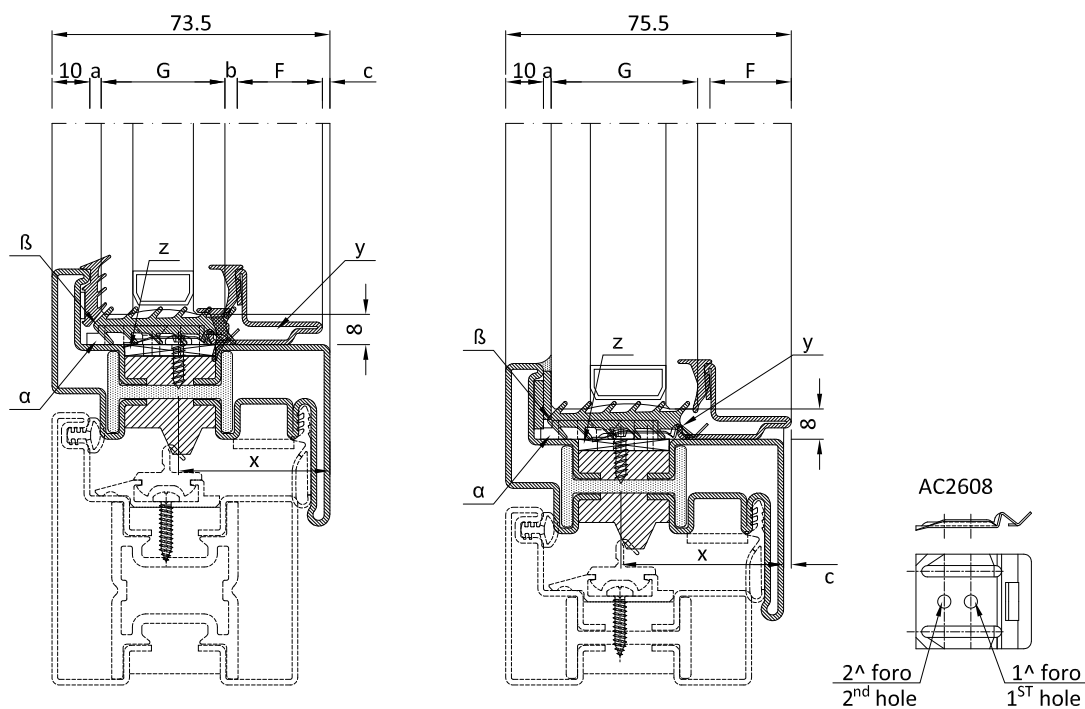

F		Guarnizioni - gaskets		G						
fermavetro glazing bead	range vetro glass range	GE1206 3 mm 	GP0095 3 mm 	spessore vetro glass thickness	asse fissaggio viti fermavetro securing axis for screws for the glazing beads	rientro fermavetro glazing beads gap	clips fissaggio fermavetro securing clips for glazing beads	spessore di compensazione * Shim *	spessore per vetro glass shim	guarnizione sotto vetro under glass gasket
Code		a	b	mm.	x	c	y	z	α	β
 P.2038	32 - 38	3	3	32	40**	2	AC2608	3 mm.	AC1020M	GE1007TT
				34	38**	0				
				36	43	-2				
				38	41	-4				

F		Guarnizioni - gaskets		G						
fermavetro glazing bead	range vetro glass range	GU2035 2 mm  + sigillatura + sealing	GP0095 3 mm 	spessore vetro glass thickness	asse fissaggio viti fermavetro securing axis for screws for the glazing beads	rientro fermavetro glazing beads gap	clips fissaggio fermavetro securing clips for glazing beads	spessore di compensazione * Shim *	spessore per vetro glass shim	guarnizione sotto vetro under glass gasket
Code		a	b	mm.	x	c	y	z	α	β
 P.2038	33 - 39	2	3	33	40**	2	AC2608	3 mm.	AC1020M	GE1007TT
				35	38**	0				
				37	43	-2				
				39	41	-4				

\*non fornito  
\*not included

\*\* fissare tramite il primo foro della clip  
\*\* screw in the upper hole of the clip

Taglio a 45° dei fermavetri effettuabile utilizzando la ganascia AT2038  
45° cutting of the glazing beads done using the cutting jaw AT2038





P.2015 - P.2028 - P.2038

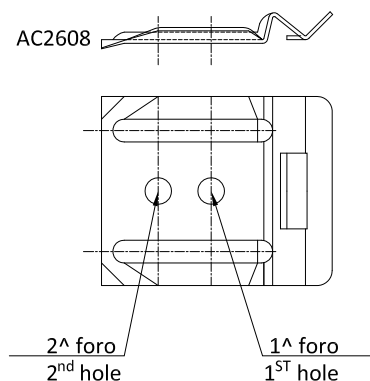
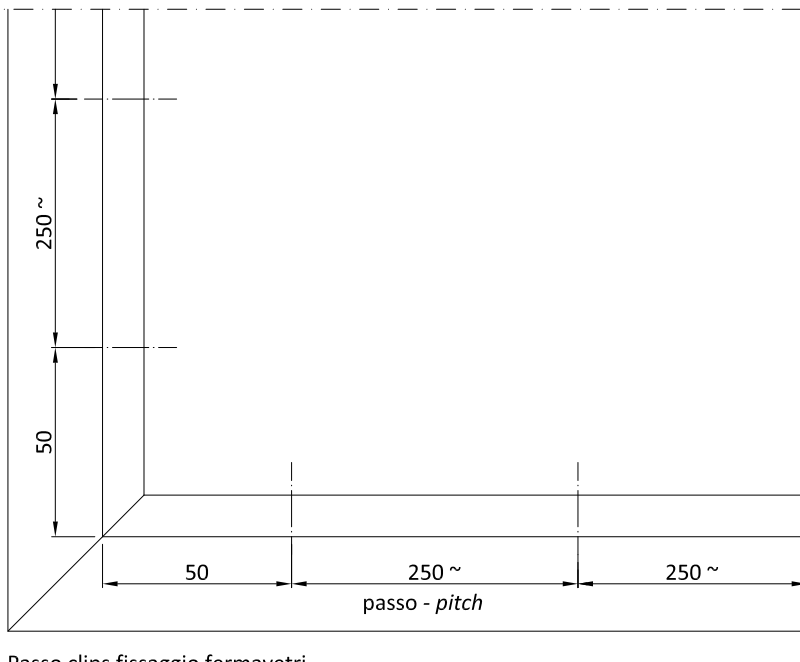

Passo clips fissaggio fermavetri  
Clip pitch for fixing the glazing beads

Per il fissaggio utilizzare TCTC 3.5 x 9.5  
For fixing use TCTC 3.5 x 9.5 screws

Fori eseguibili con maschera AT2828  
Holes to be done with AT2828

P.2007 - P.1007 - P.2008 - P.2009

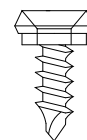
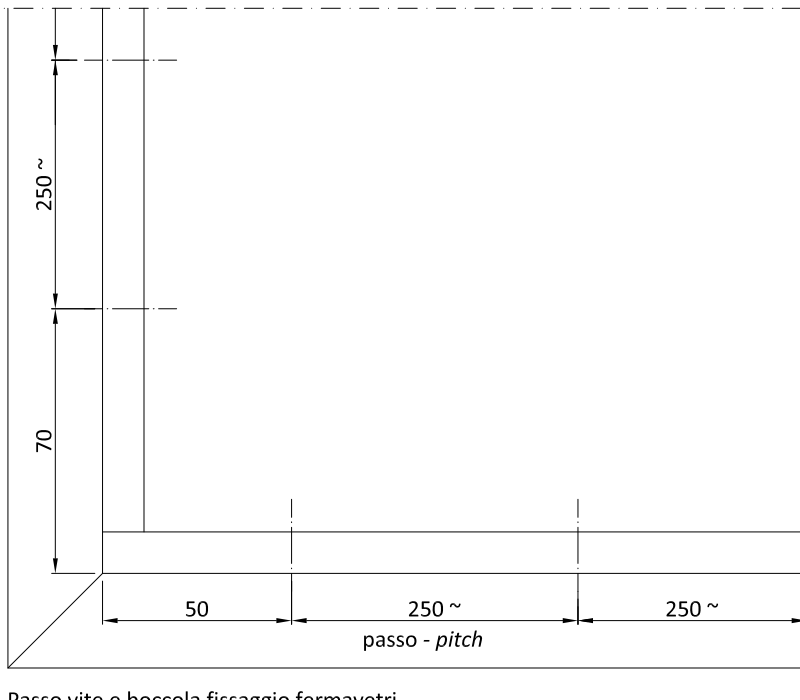

CV5001 + CV5012  
CV5001I + CV5012I

Passo vite e boccola fissaggio fermavetri  
Clip pitch to fix glazing beads

Fori eseguibili con maschera AT1234  
Holes to be done with AT1234

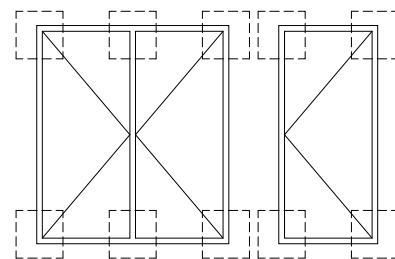

Acciaio zincato - Acciaio Corten - Acciaio inox  
Saldare in continuo le superfici di contatto indicate

*Galvanised steel - Cor-ten steel - Stainless steel*  
*Seam-weld the shown areas*

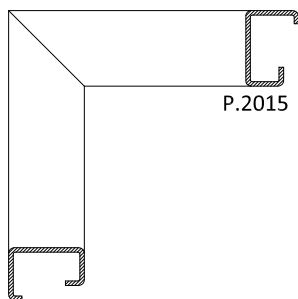
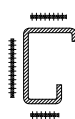

P.2015

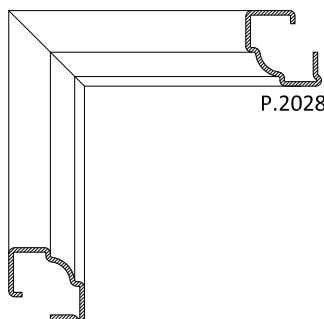
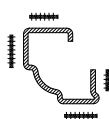

P.2028

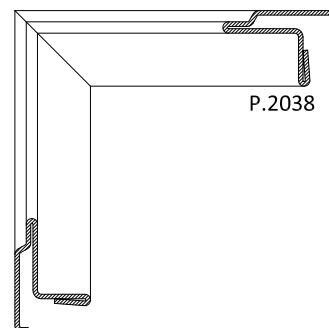
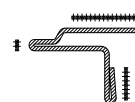

P.2038

Ottone  
Saldare a TIG a punti le zone indicate.

*Brass*  
*Spot weld (TIG) the marked areas.*

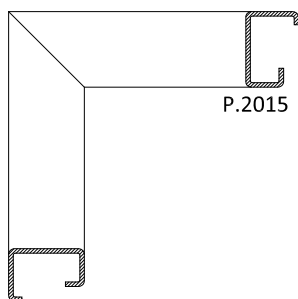
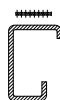

P.2015

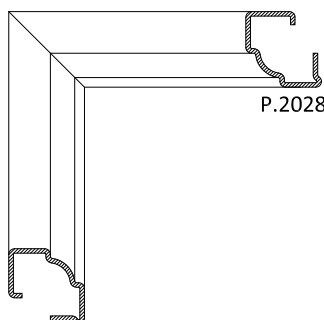
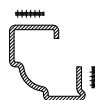

P.2028

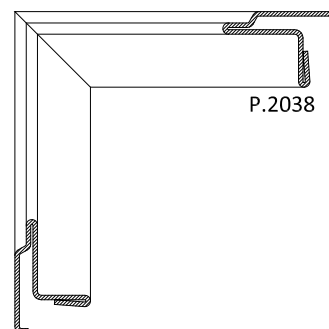
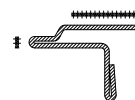

P.2038

P.2028  
Taglio a 45° dei fermavetri effettuabile utilizzando la ganascia AT2029  
*45° cutting of the glazing beads done using the cutting jaw AT2029*

P.2038  
Taglio a 45° dei fermavetri effettuabile utilizzando la ganascia AT2038  
*45° cutting of the glazing beads done using the cutting jaw AT2038*

PARTICOLARE "A" \_ DETAIL "A"

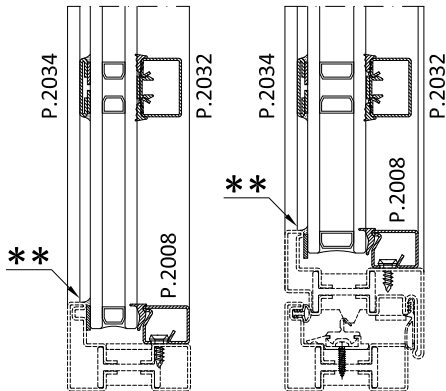
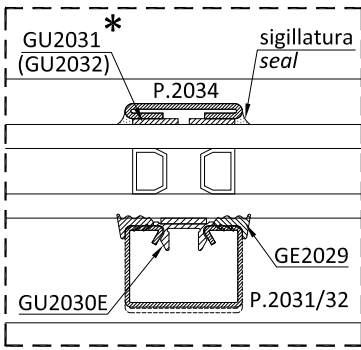

PARTICOLARE "B" \_ DETAIL "B"

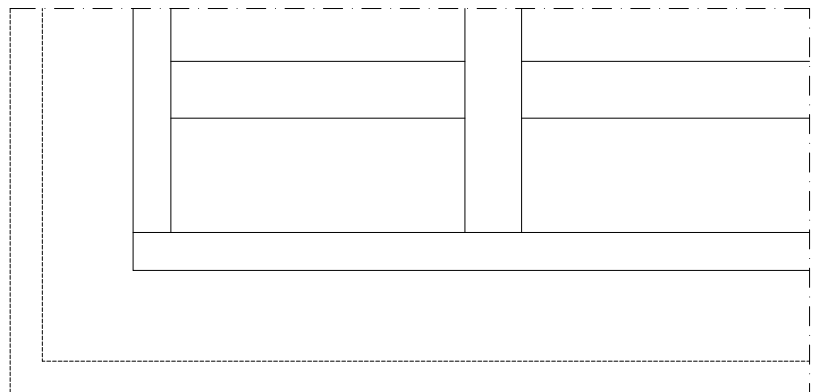
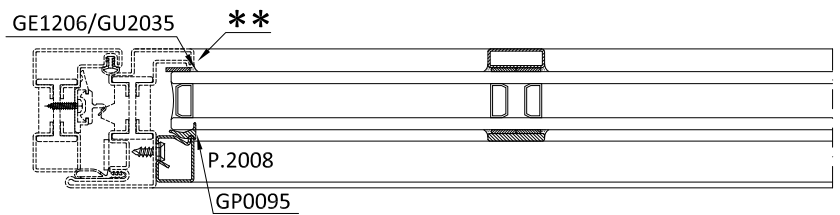
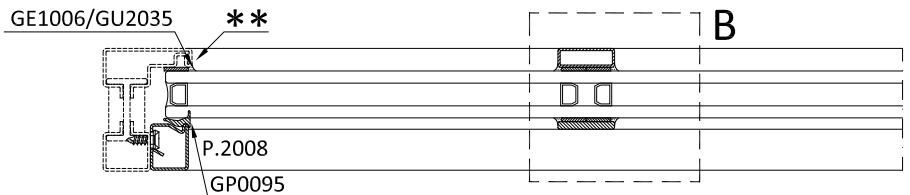
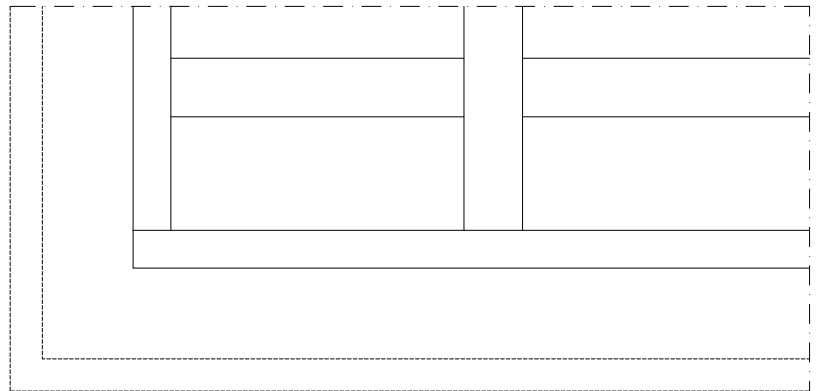
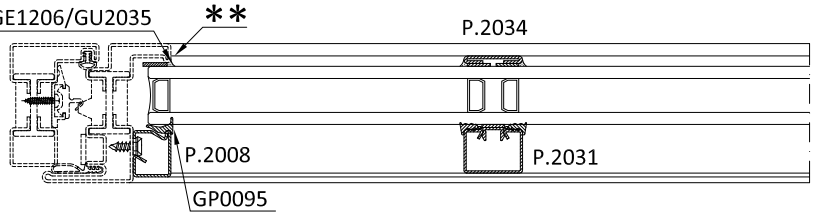
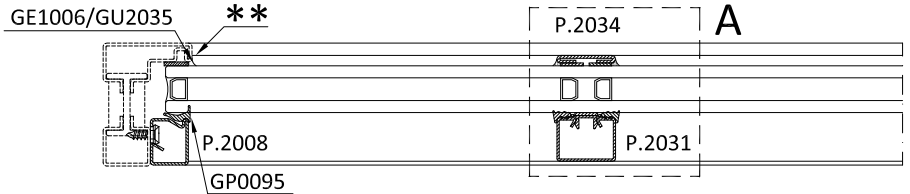
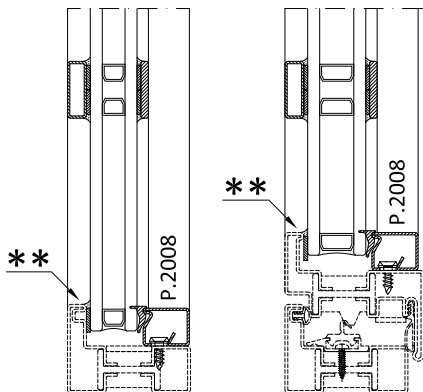
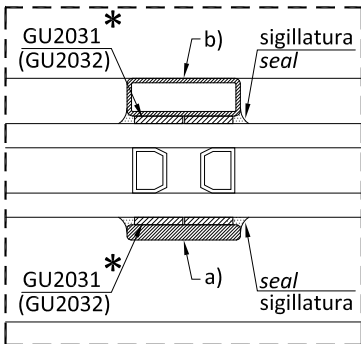

\* Per utilizzo dividivetro SOLO orizzontali o SOLO verticali GU2031  
 Per utilizzo dividivetro orizzontali e verticali GU2031 verticalmente GU2032 orizzontalmente  
 For ONLY horizontal or ONLY vertical glazing beads use GU2031  
 For horizontal and vertical glazing beads use GU2031 vertically and GU2032 horizontally

\*\* Saldare o sigillare  
 Weld or seal

a) profilo commerciale | section profile 30x4 mm  
 b) profilo commerciale | section profile 30x10 mm

PARTICOLARE "C" \_ DETAIL "C"

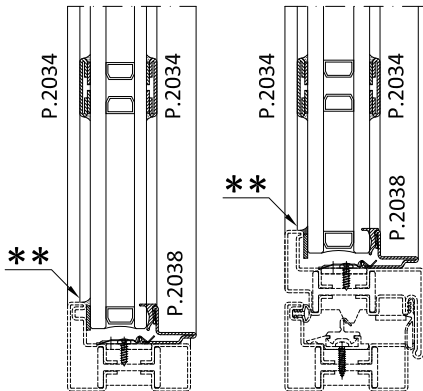
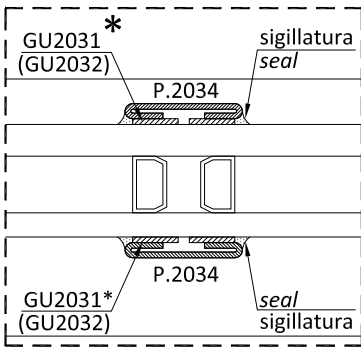

PARTICOLARE "D" \_ DETAIL "D"

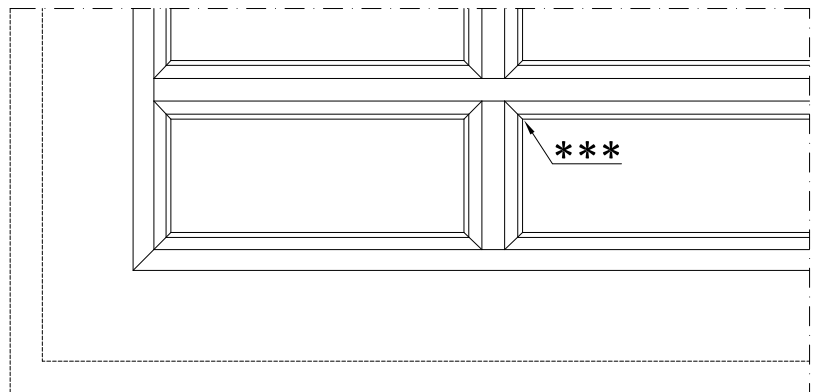
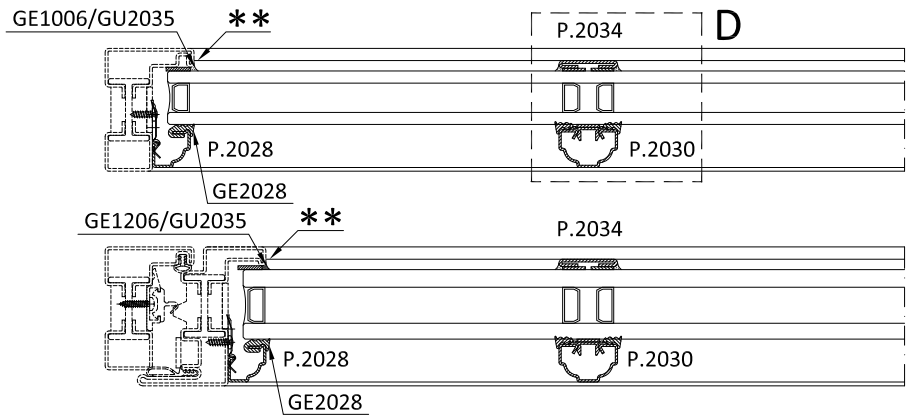
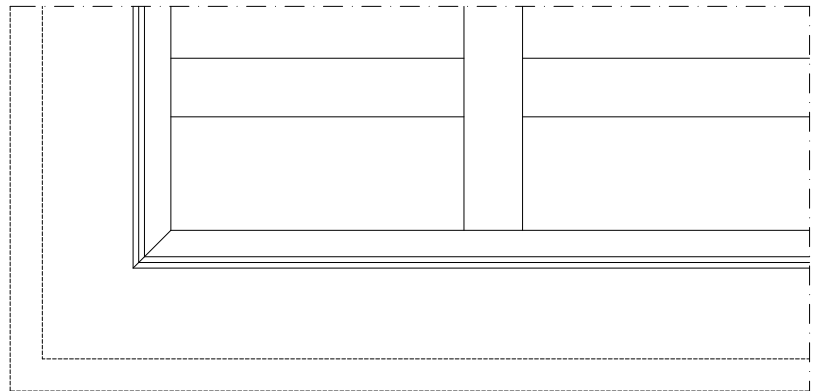
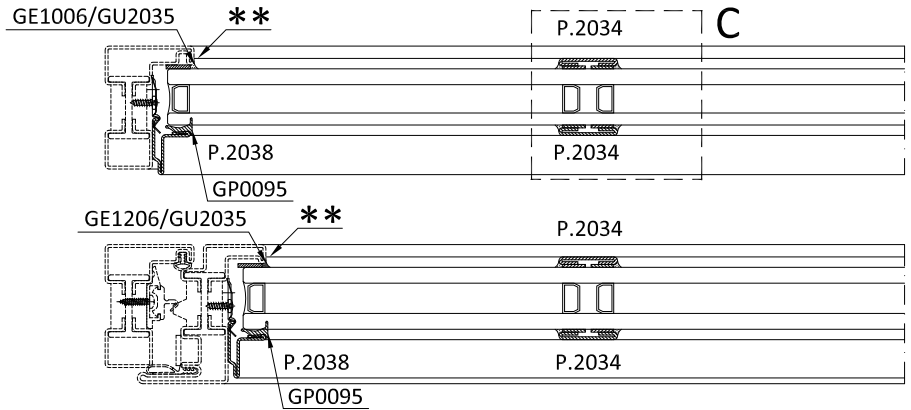
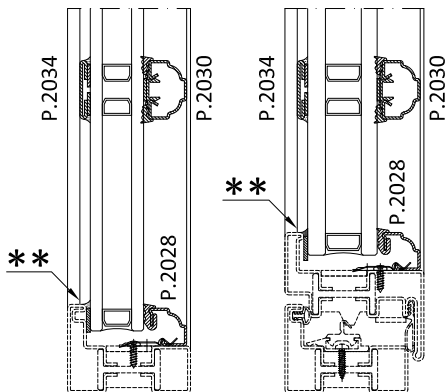
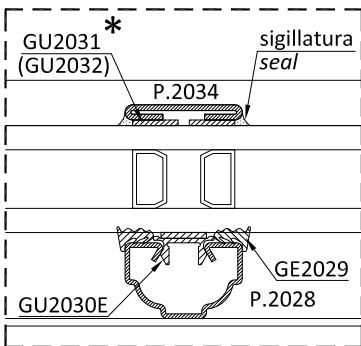

\* Per utilizzo dividivetro SOLO orizzontali o SOLO verticali GU2031  
 Per utilizzo dividivetro orizzontali e verticali GU2031 verticalmente GU2032 orizzontalmente  
 For ONLY horizontal or ONLY vertical glazing beads use GU2031  
 For horizontal and vertical glazing beads use GU2031 vertically and GU2032 horizontally

\*\* Saldare o sigillare  
 Weld or seal

\*\*\* Lavorazione di intestatura effettuabile con stampo AT2030  
 Processing of butt jointing carried out with a mould

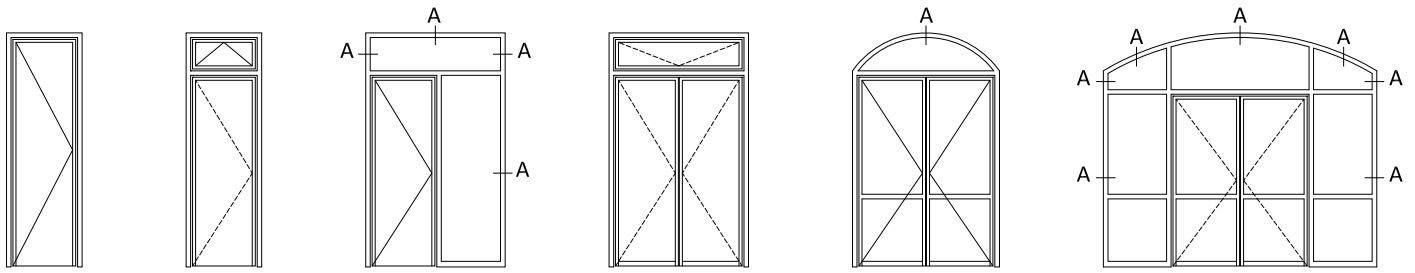

A.1a

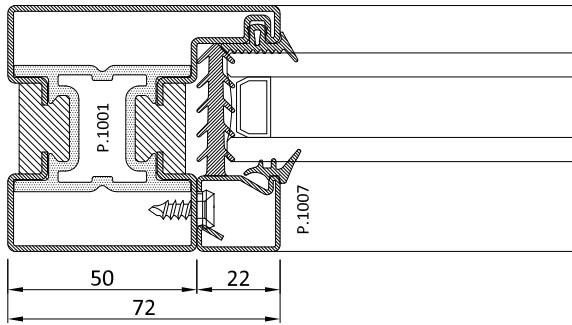

A.1b

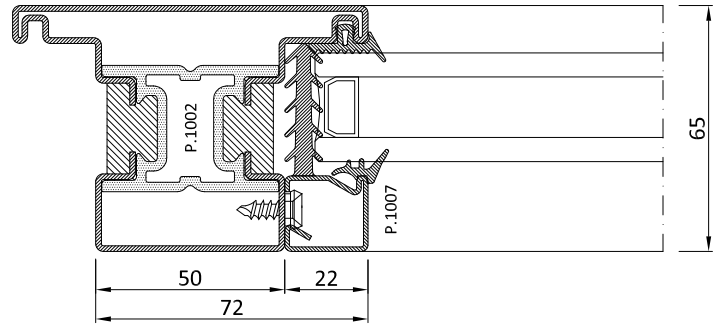

A.1c

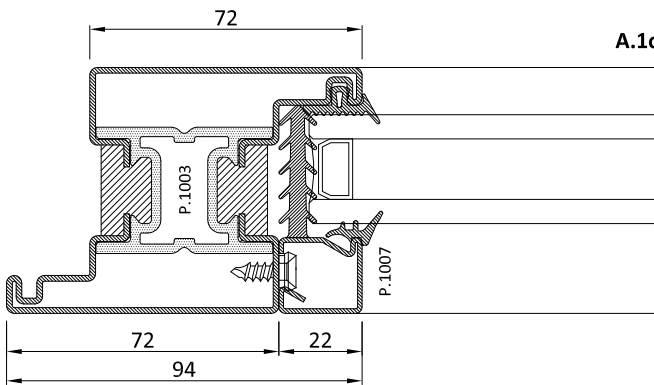

A.2a

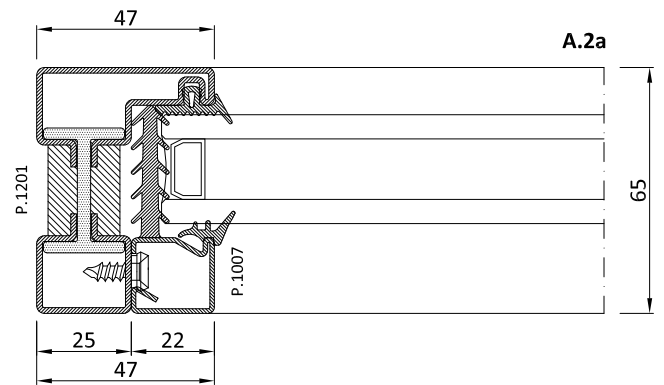

A.2b

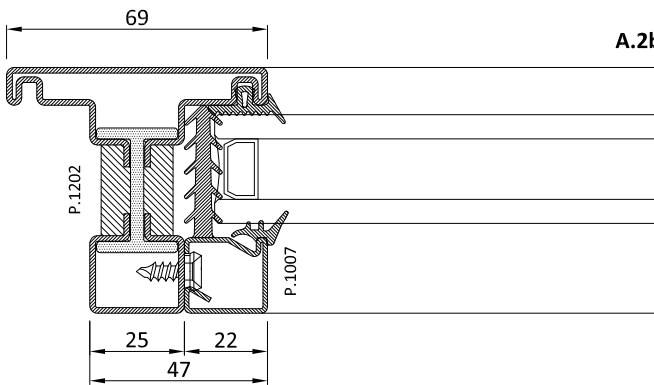

A.2c

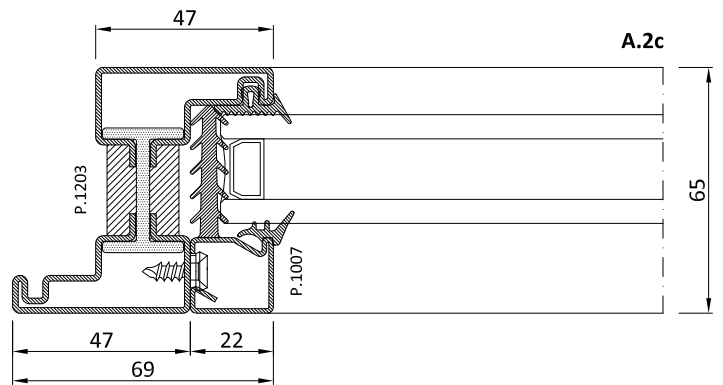

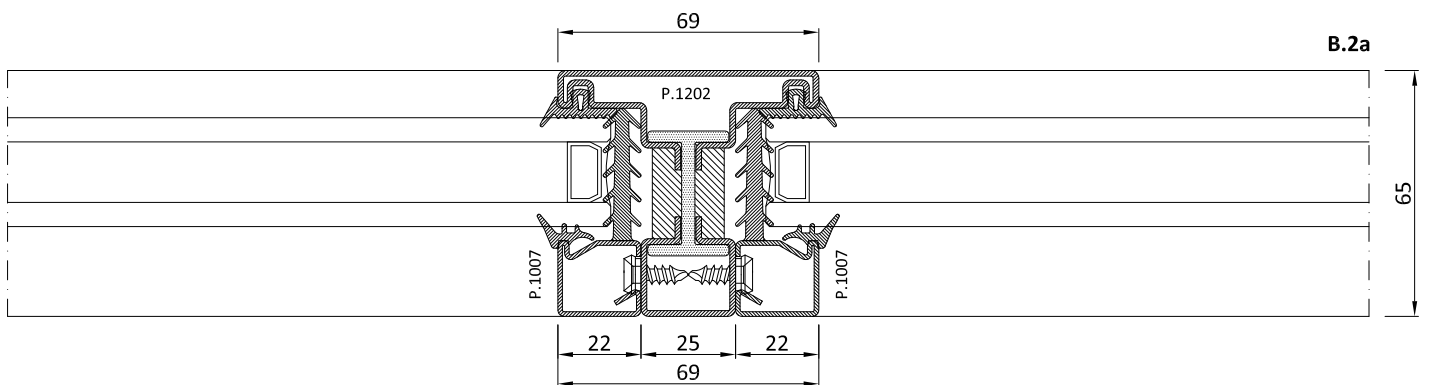
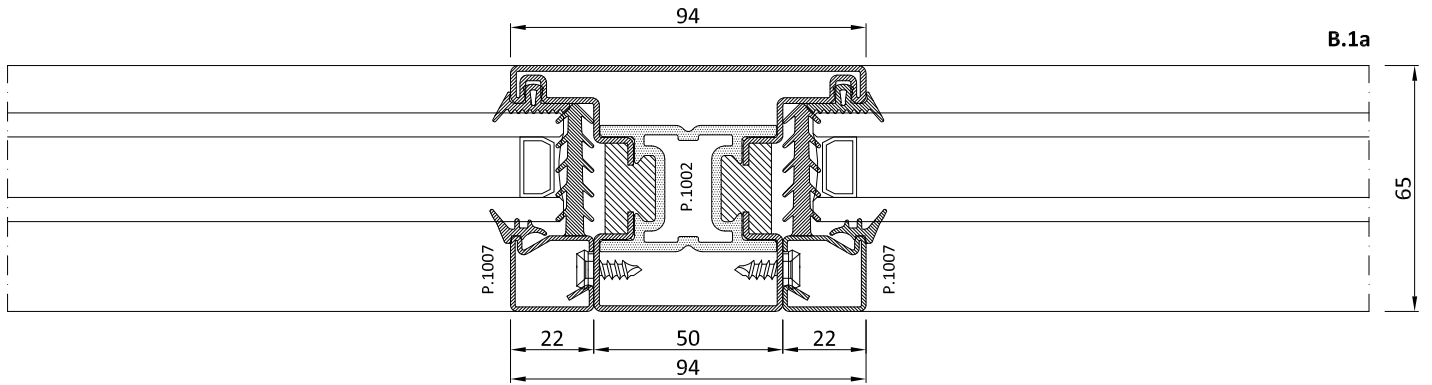
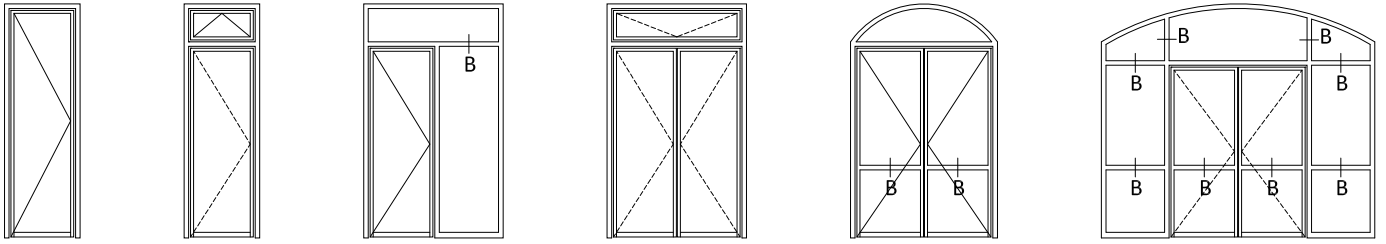

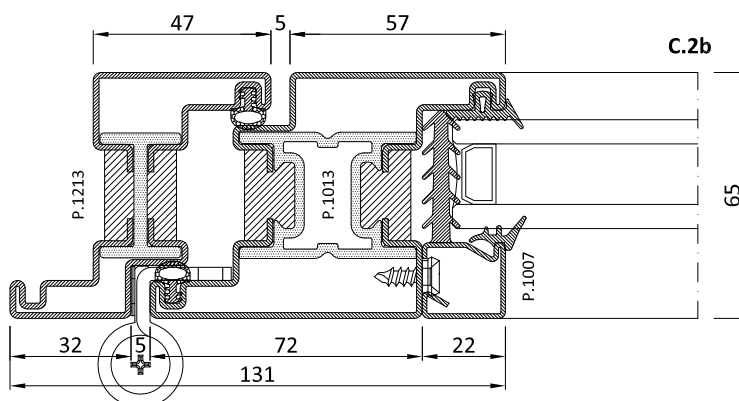
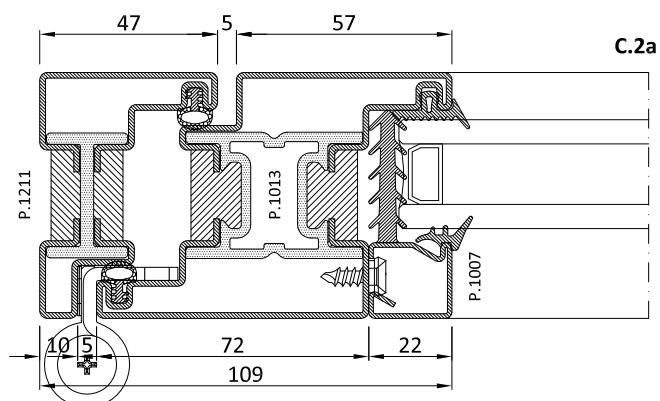
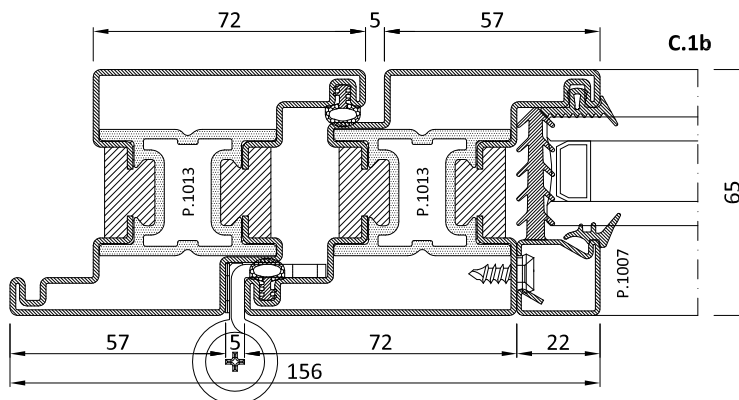
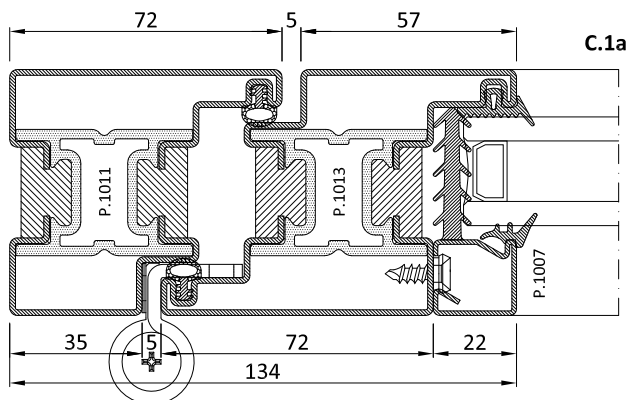
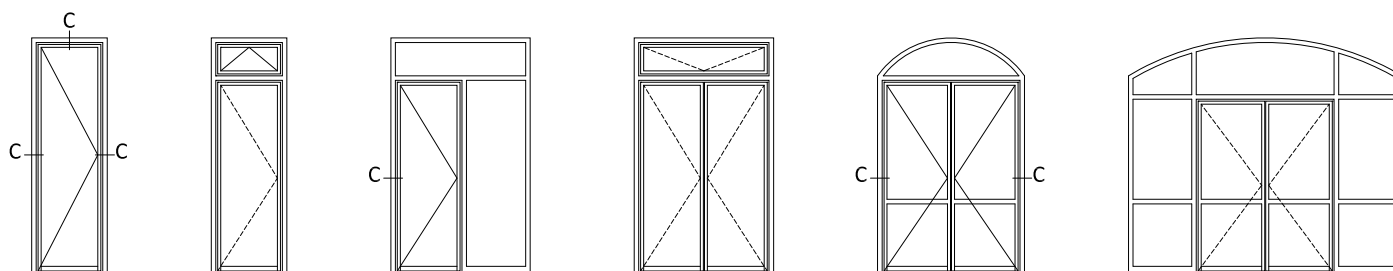

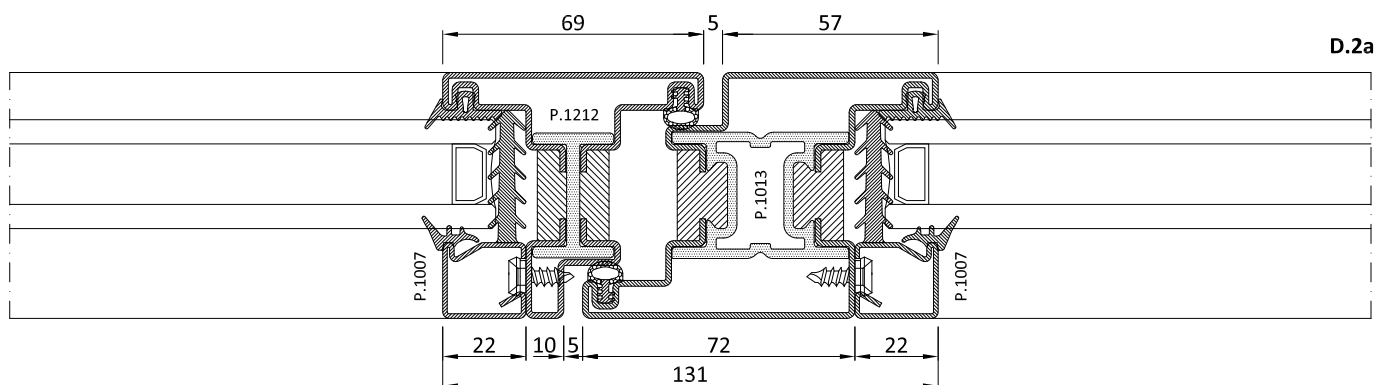
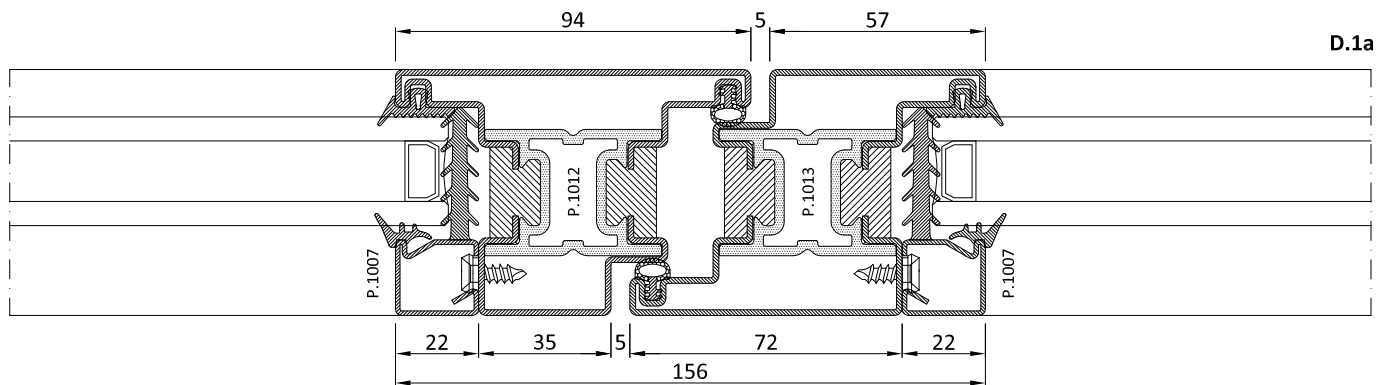
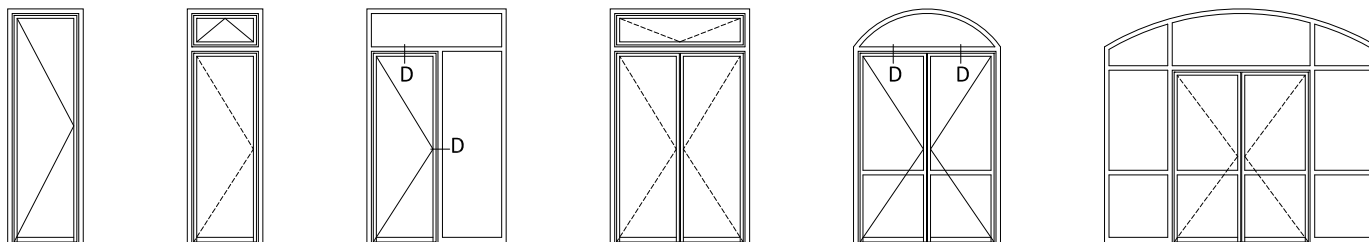



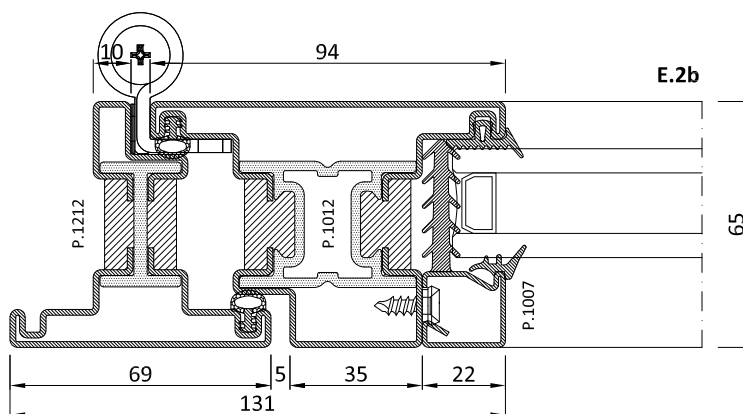
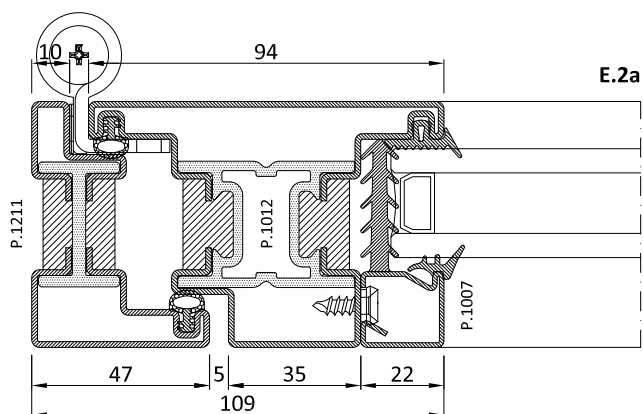
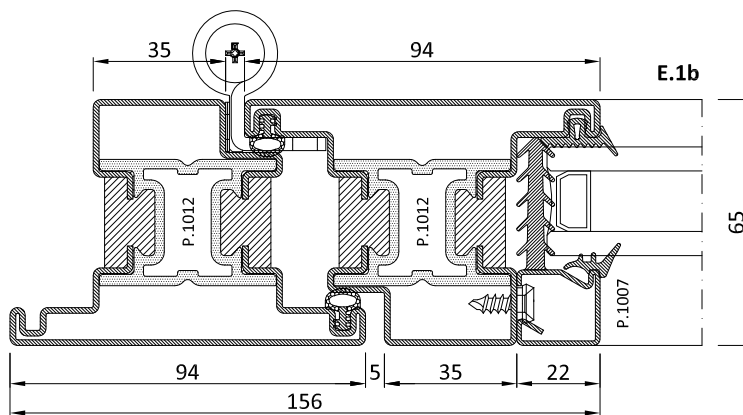
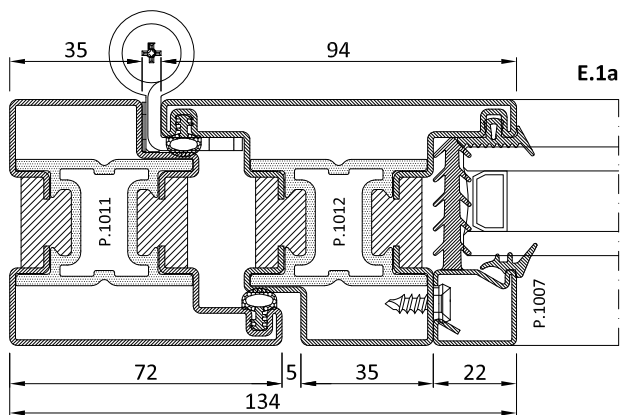
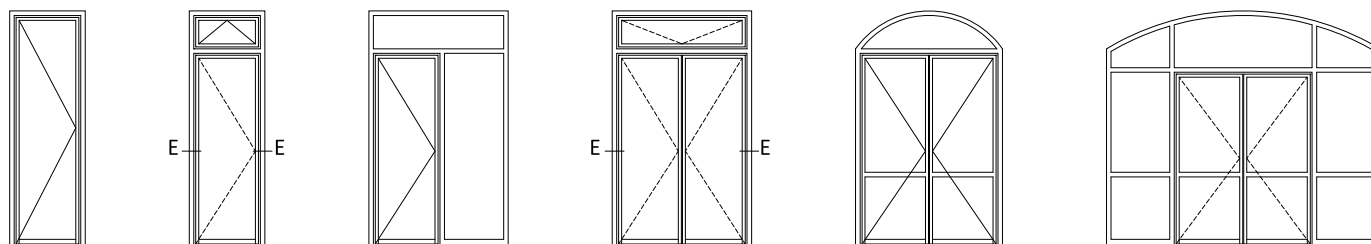

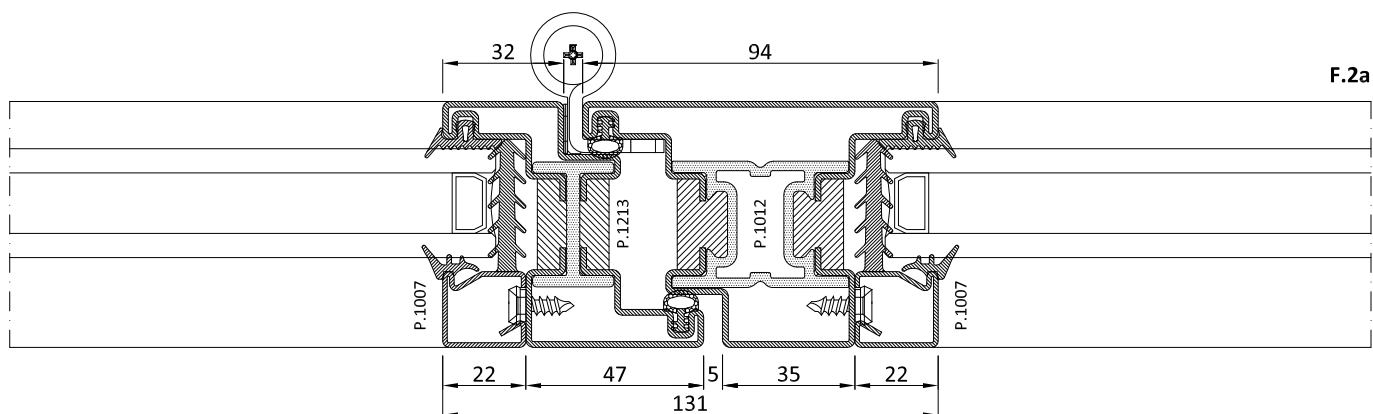
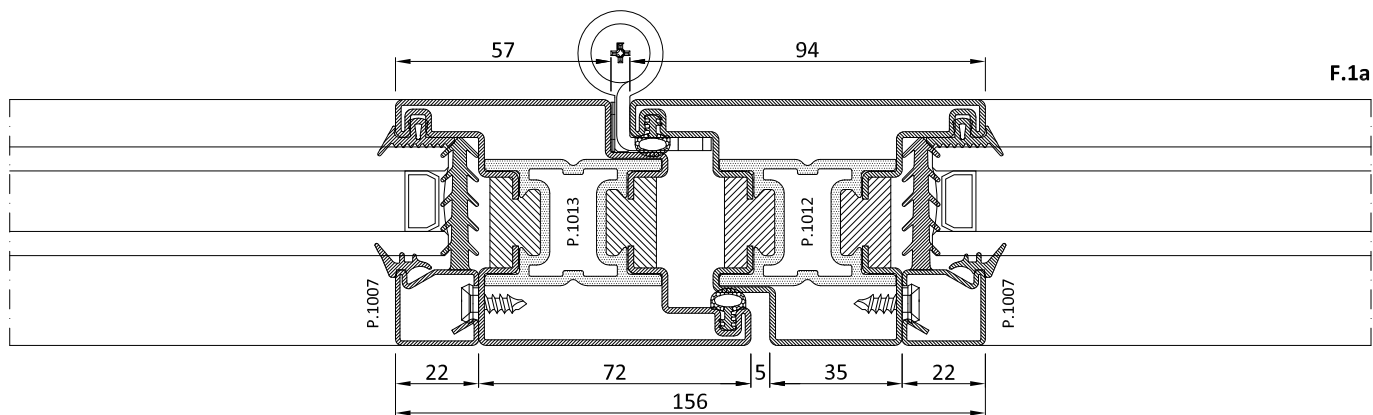
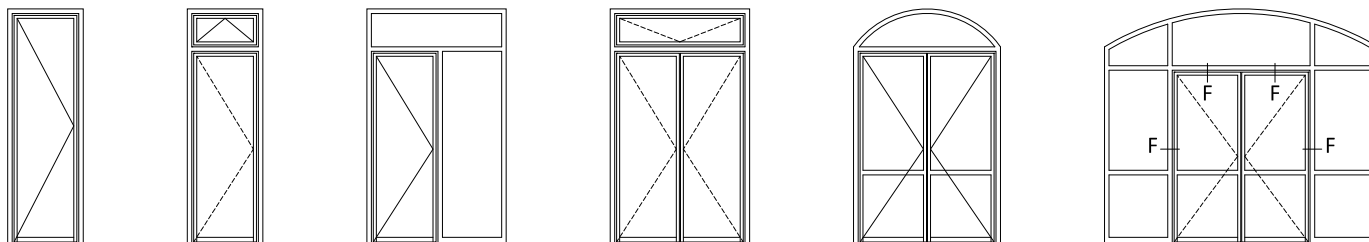

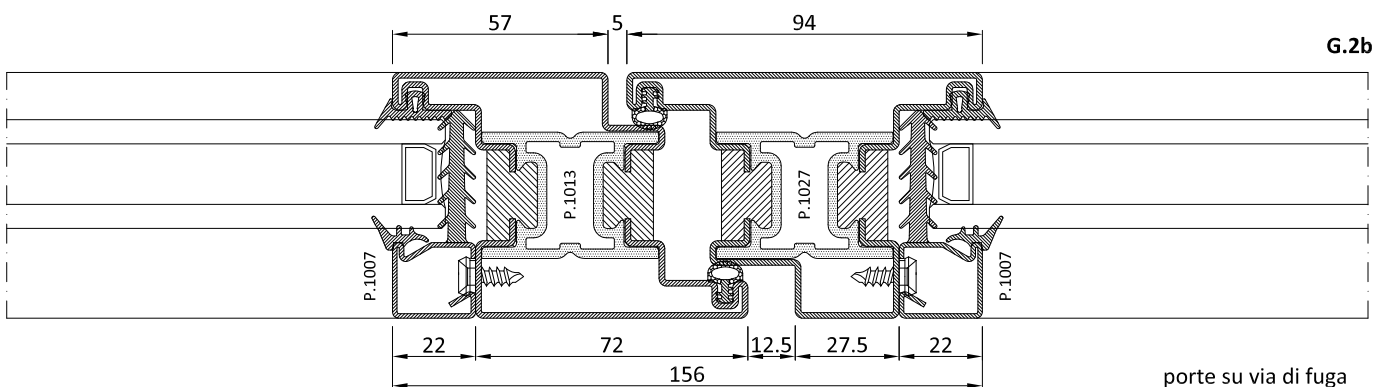
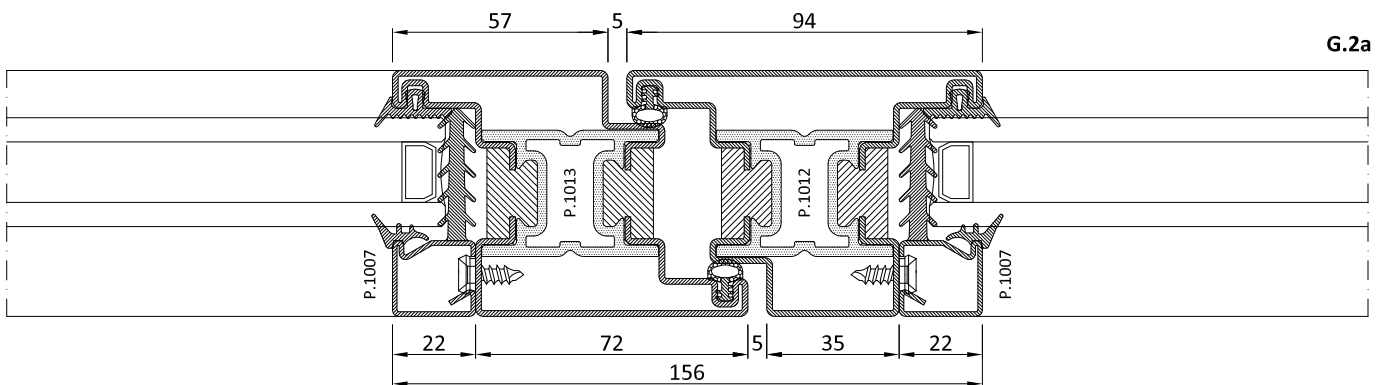
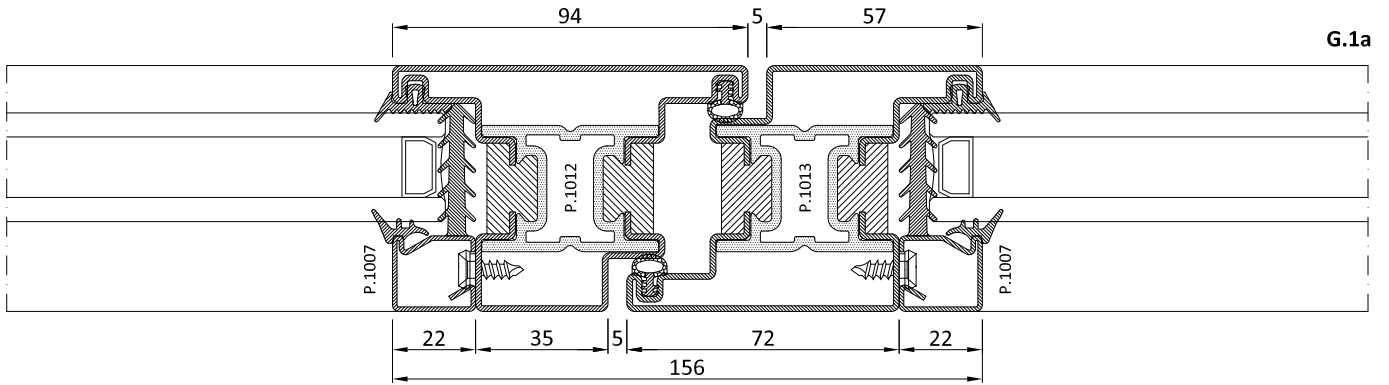
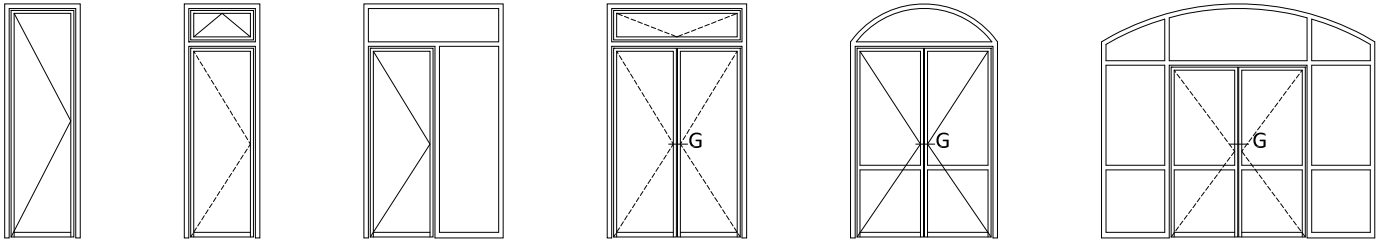

porte su via di fuga  
Escape route door

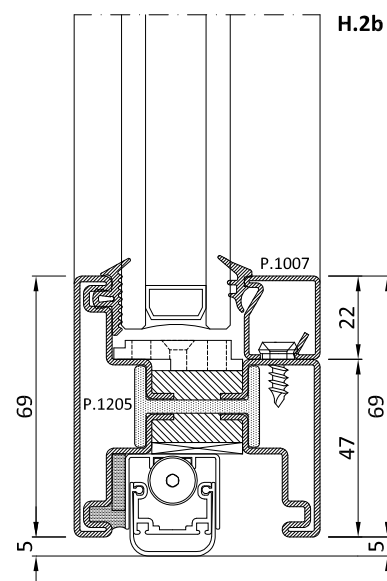
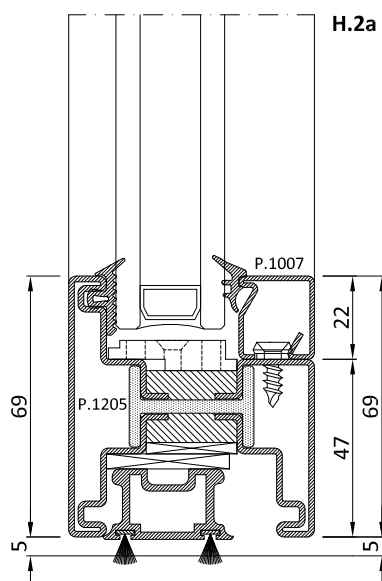
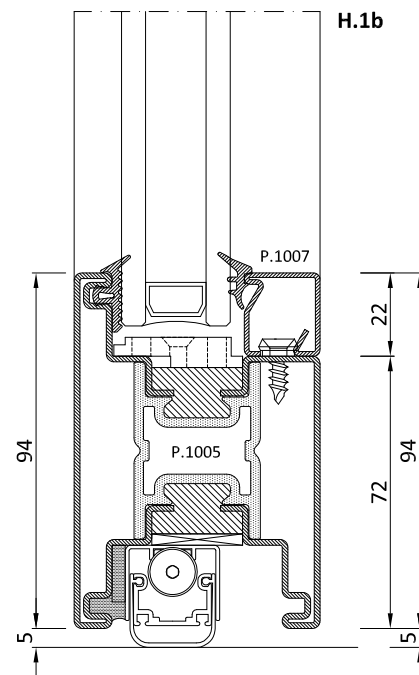
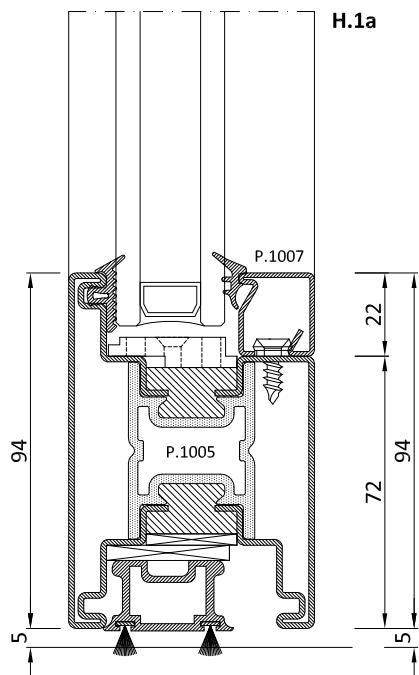
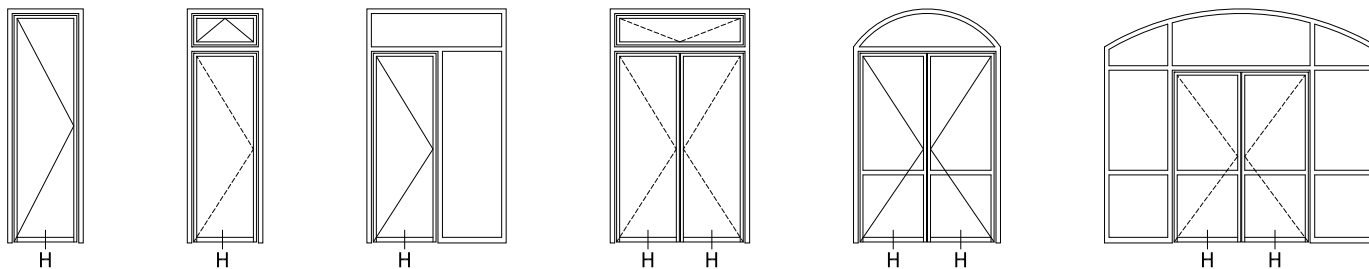

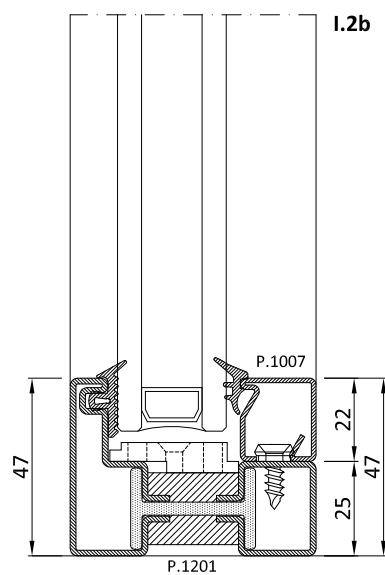
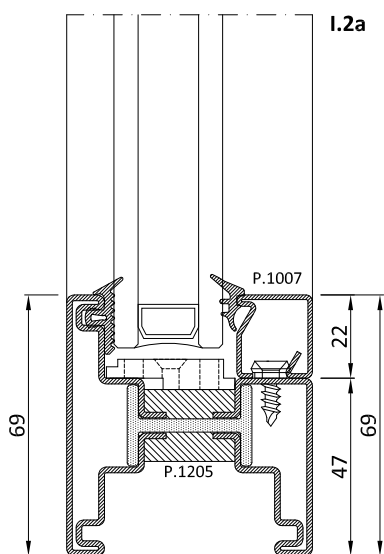
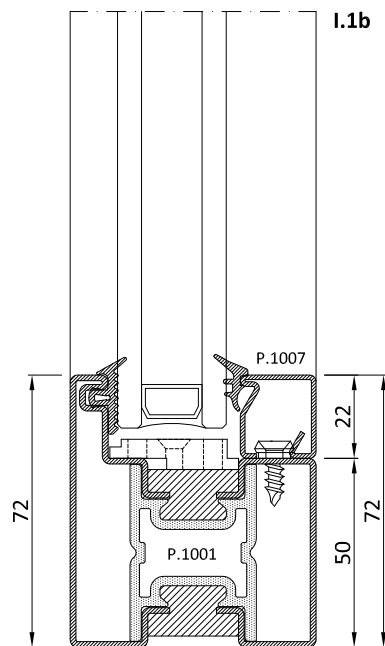
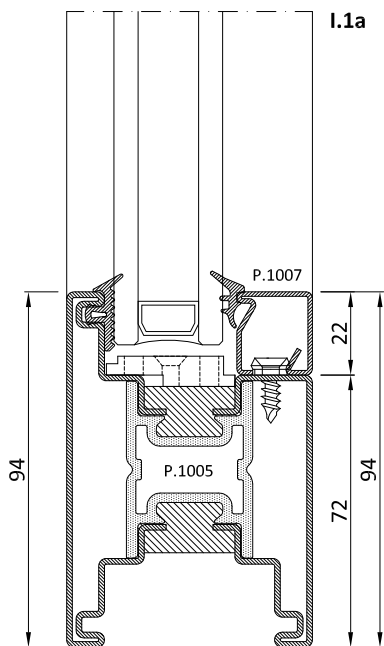
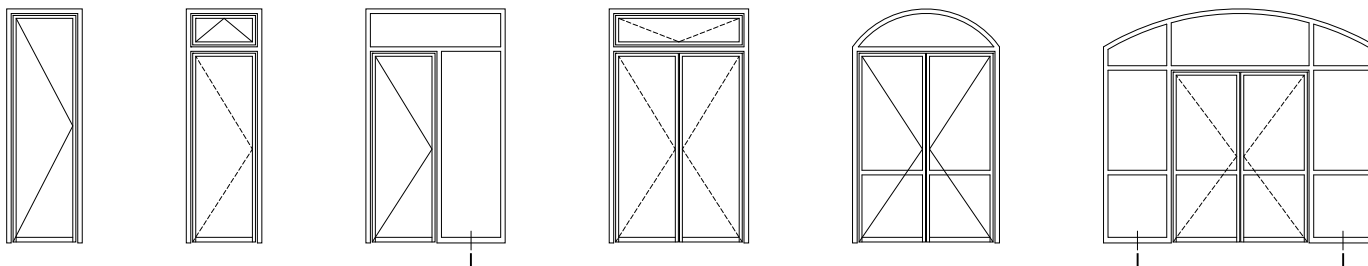

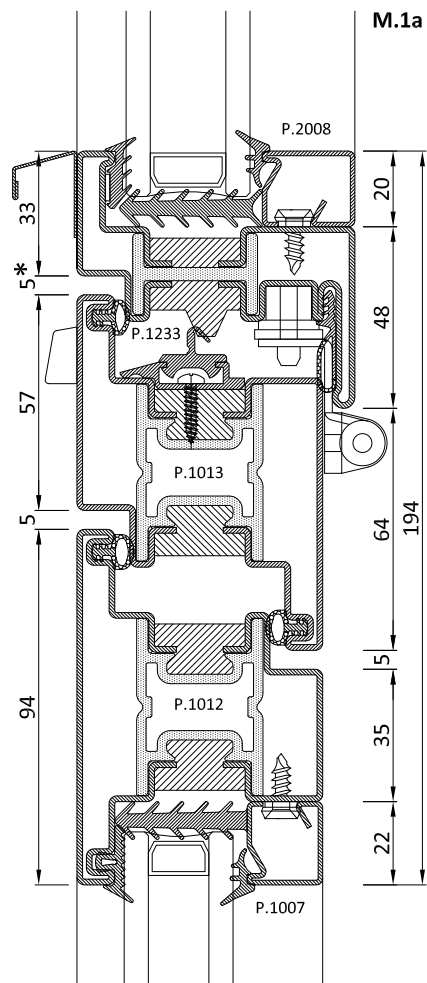
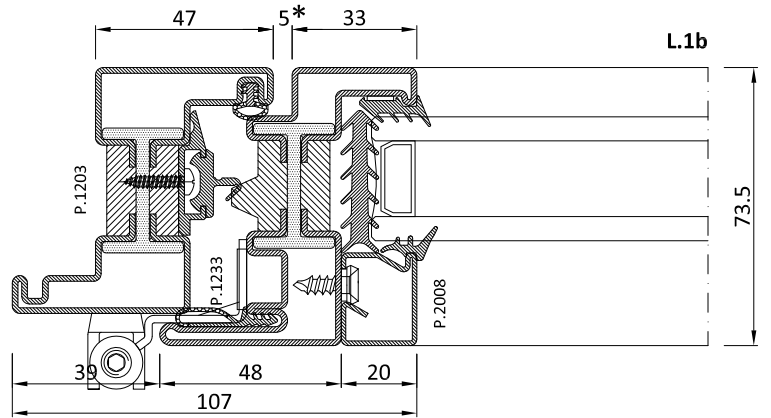
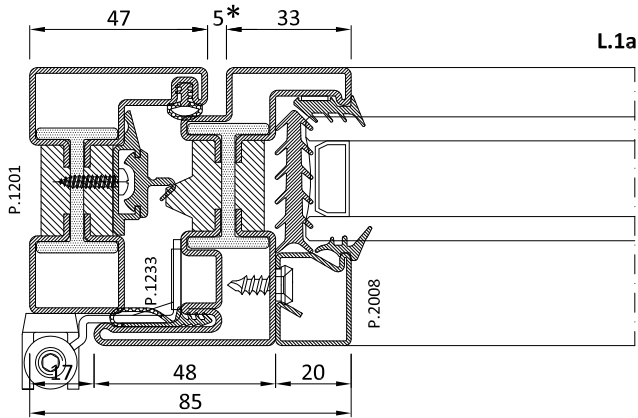
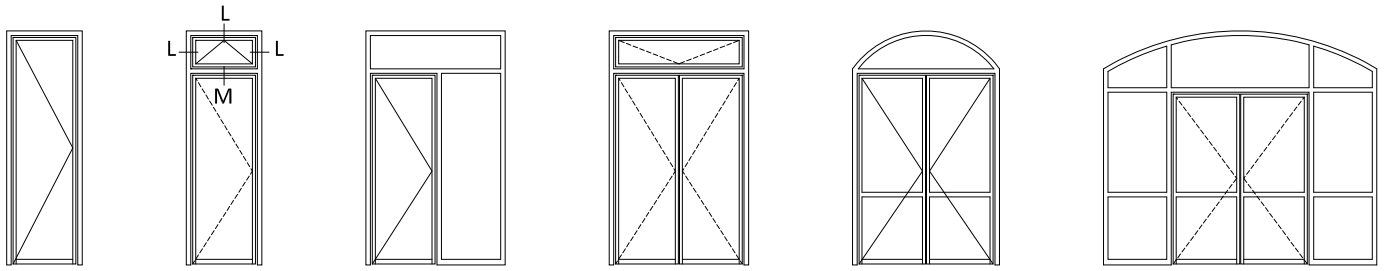

\* Vedi tabella 4.1.5  
\* See chart 4.1.5

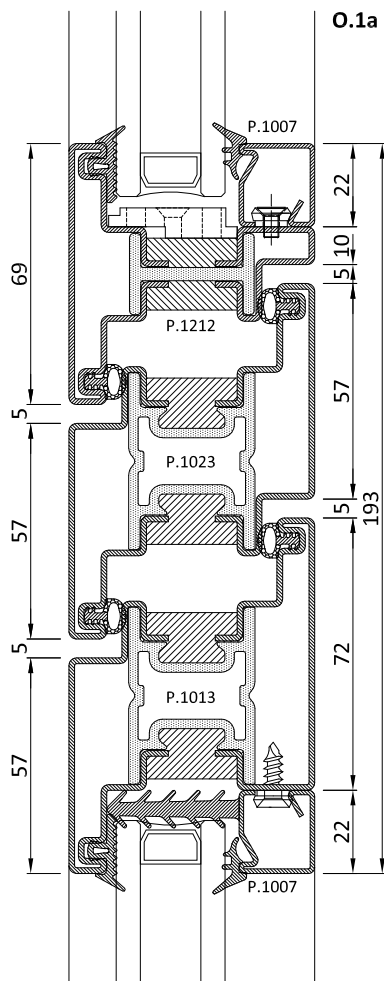
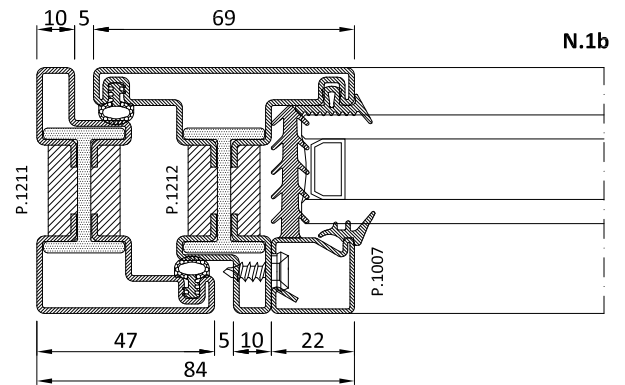
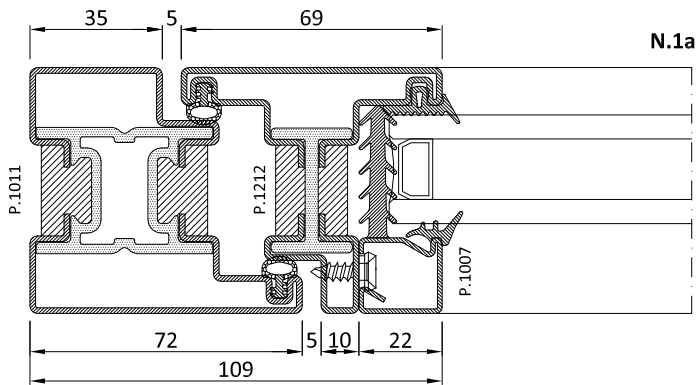
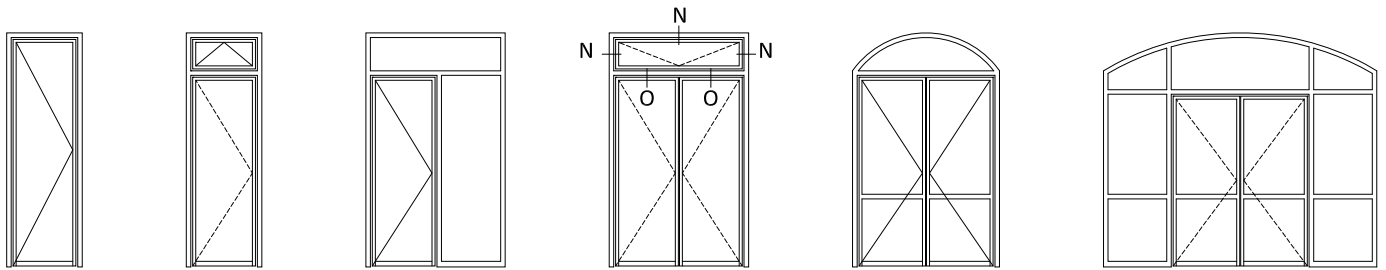

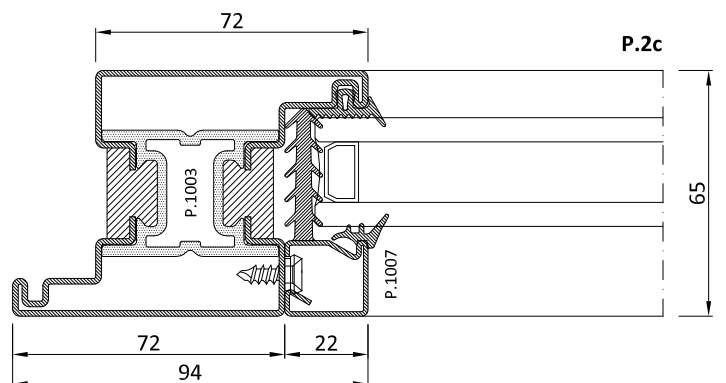
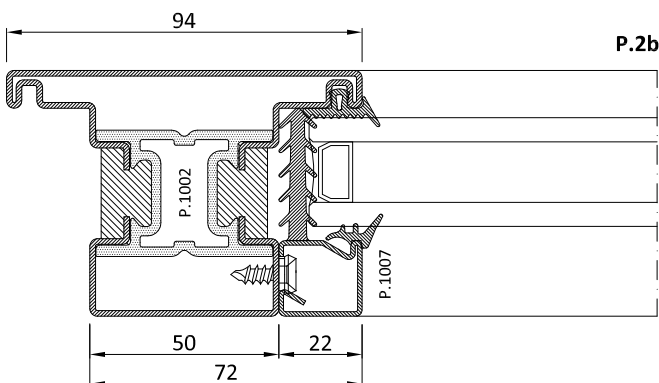
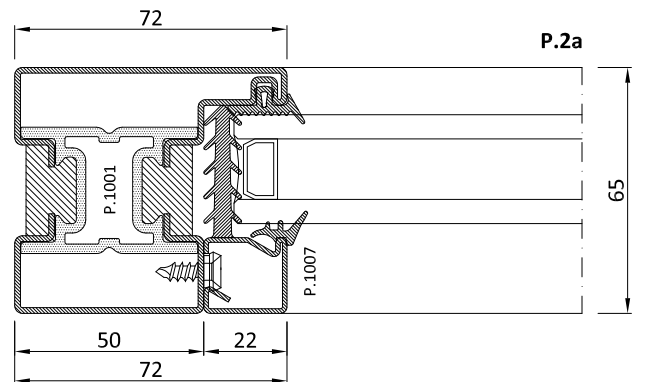
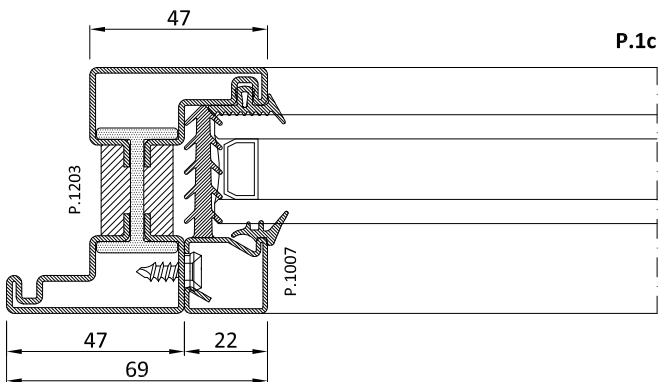
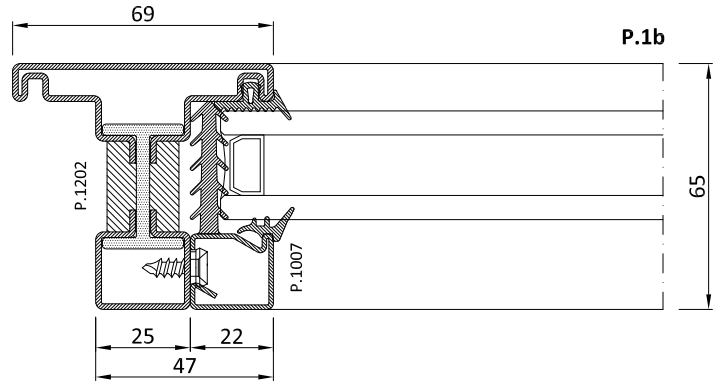
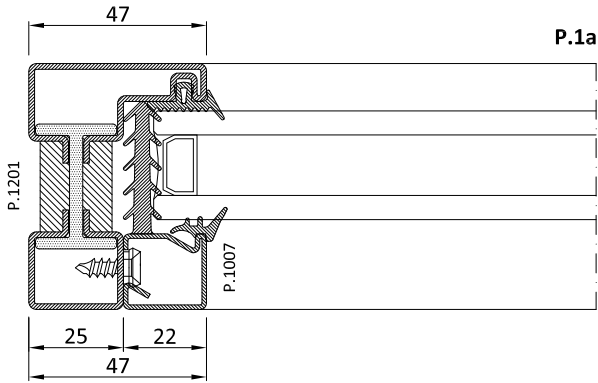
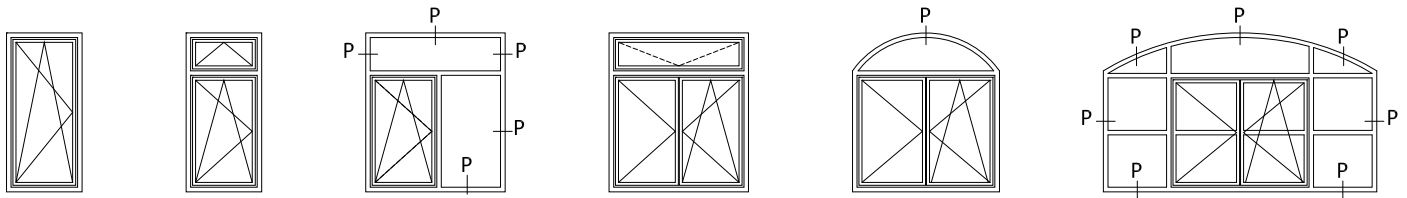



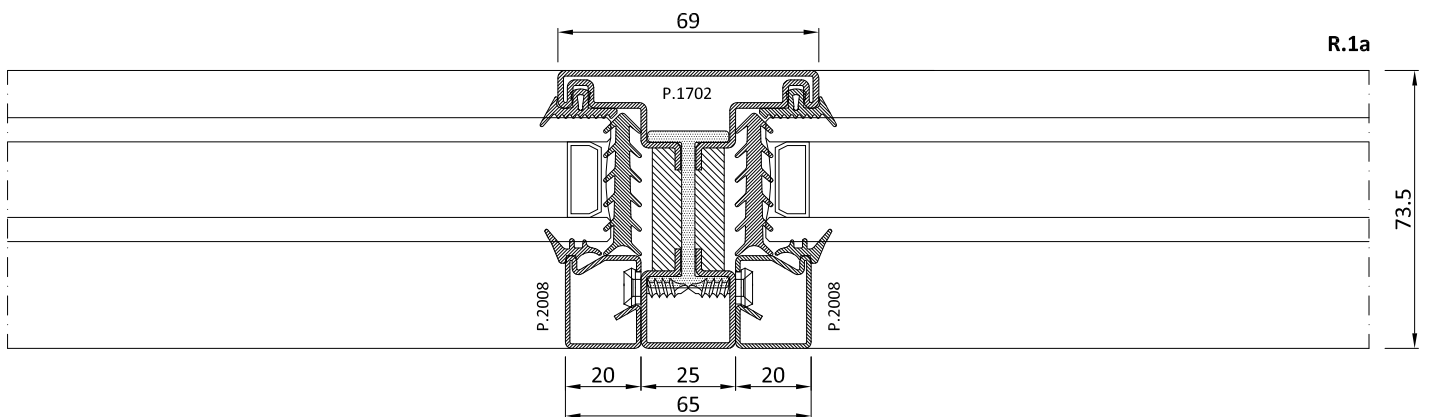
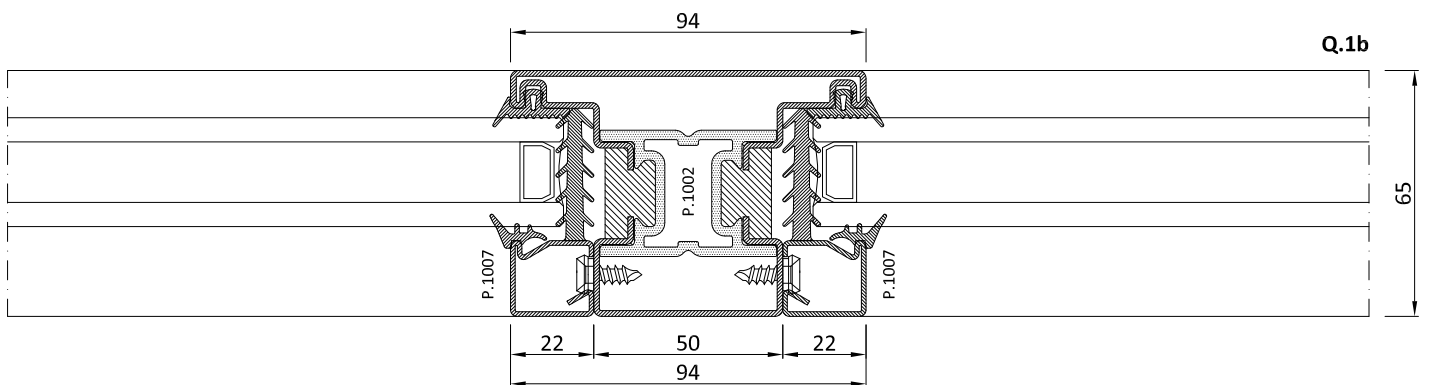
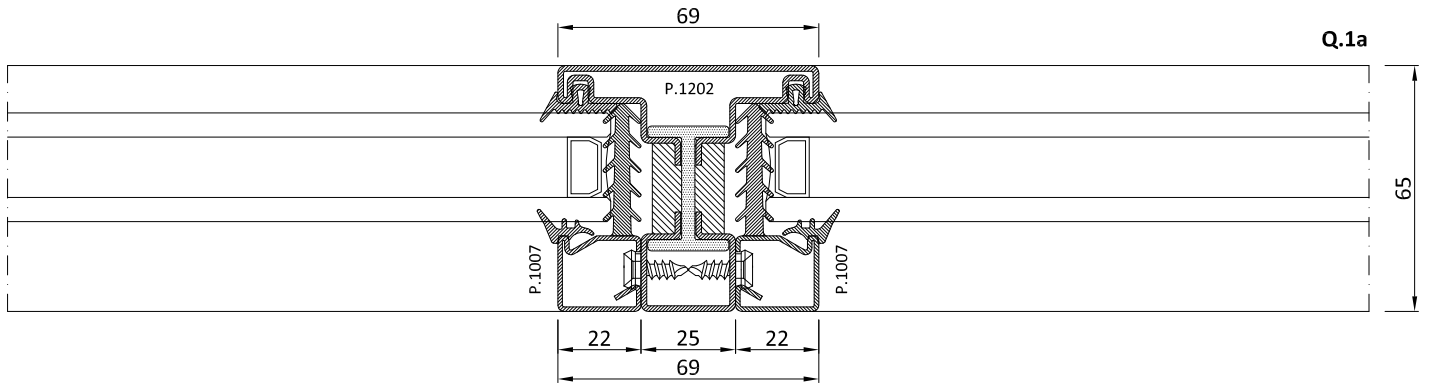
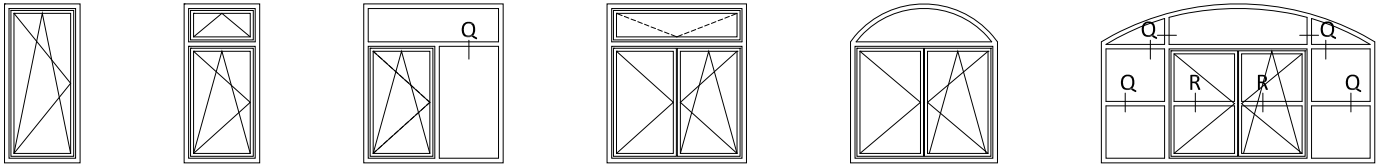

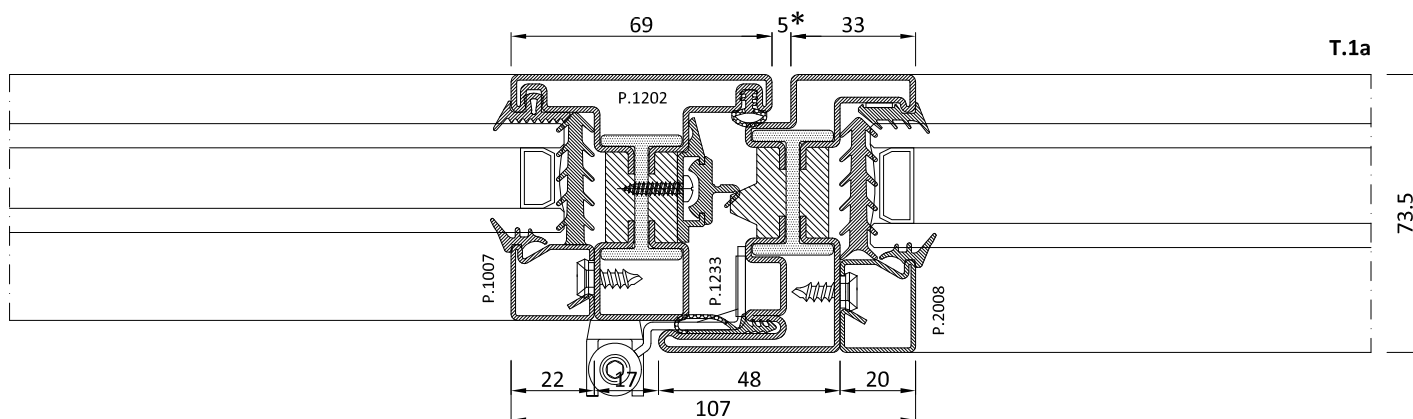
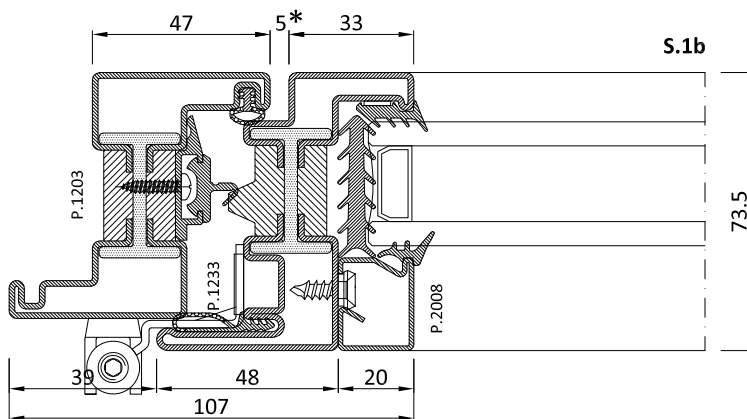
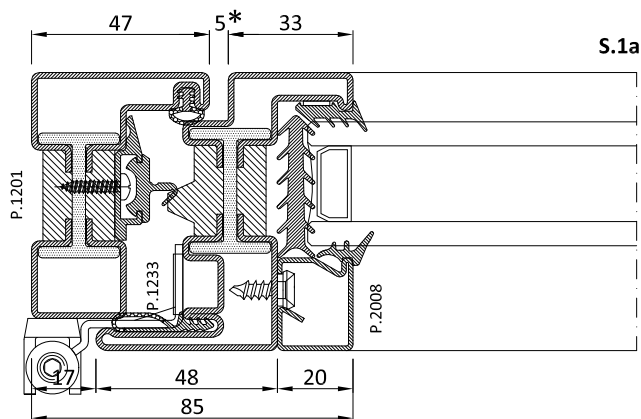
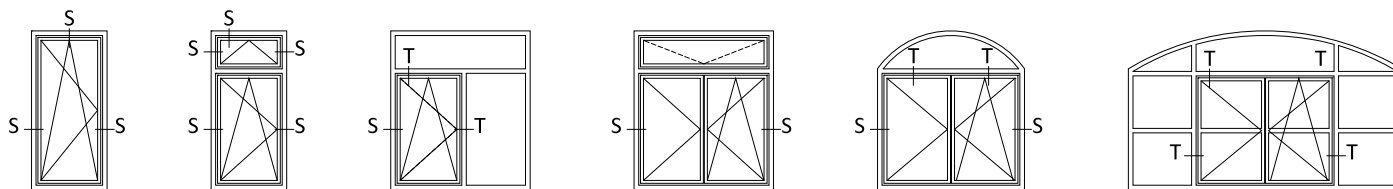

\* Vedi tabella 4.1.5  
\* See chart 4.1.5

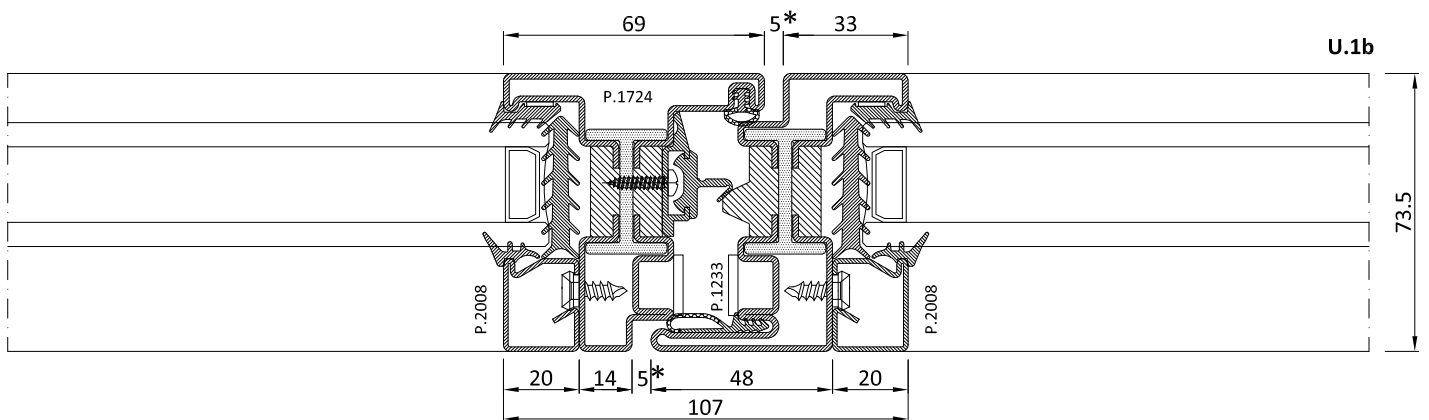
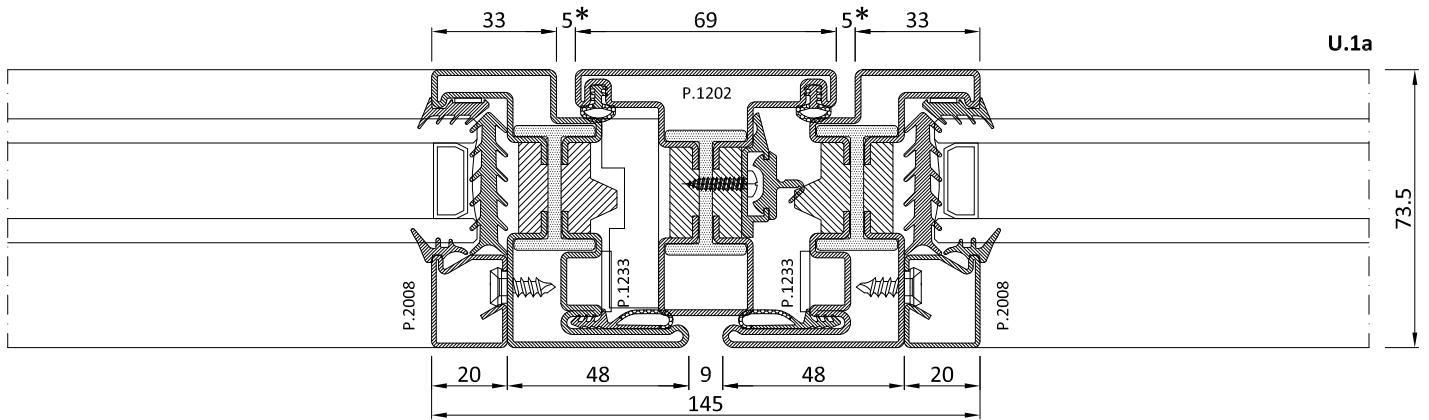
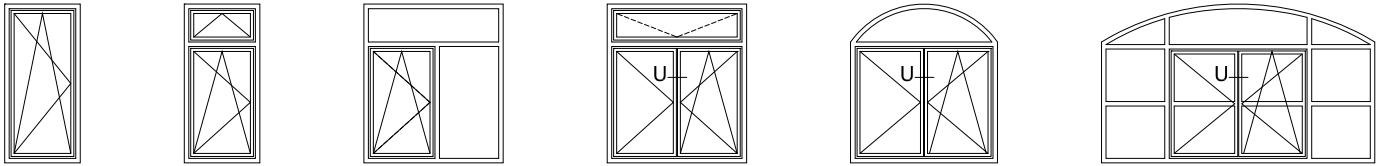

\* Vedi tabella 4.1.5  
\* See chart 4.1.5

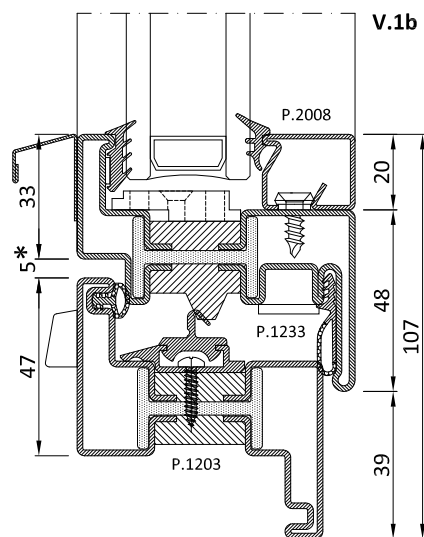
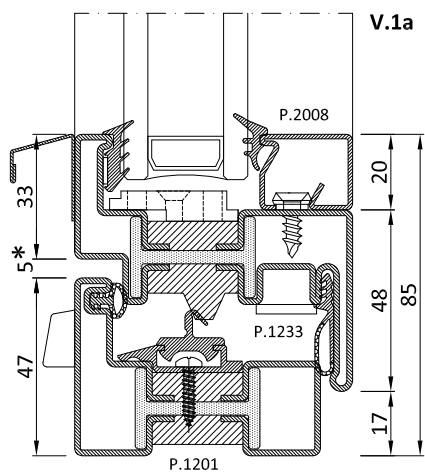
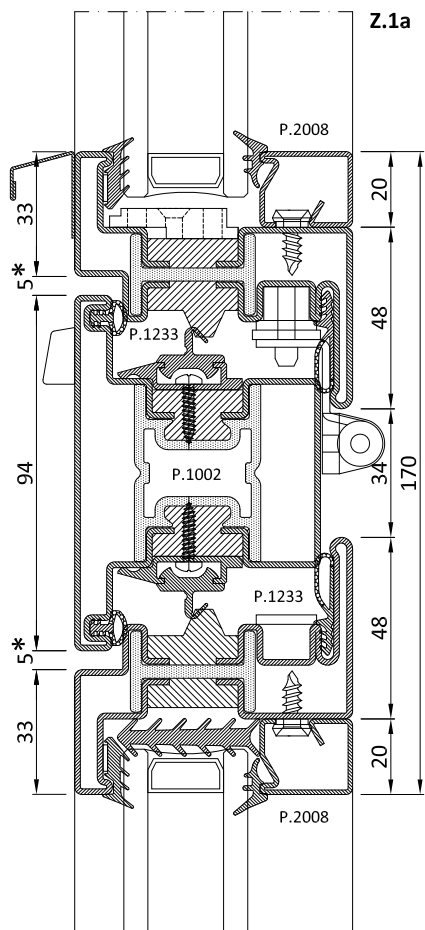
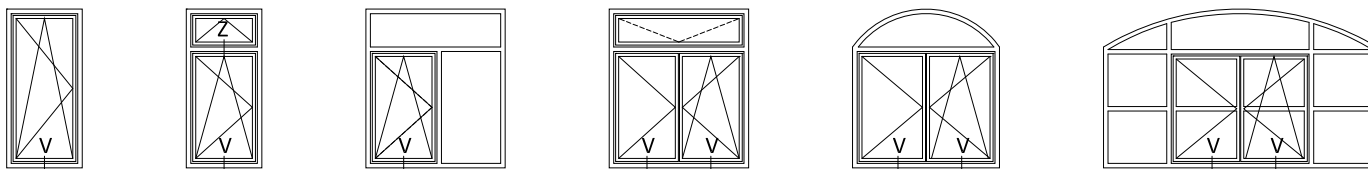

\* Vedi tabella 4.1.5  
\* See chart 4.1.5

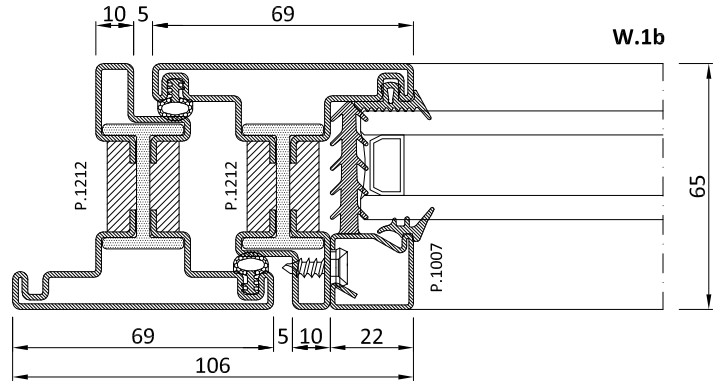
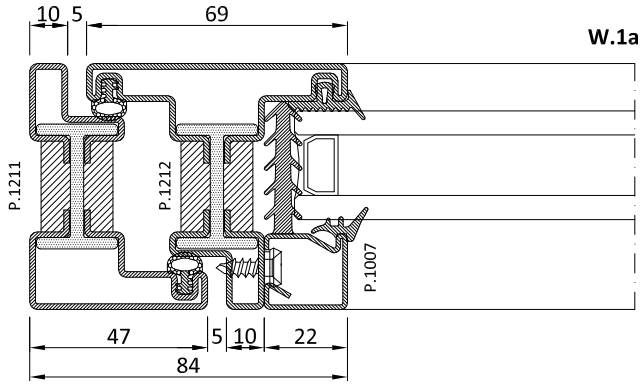
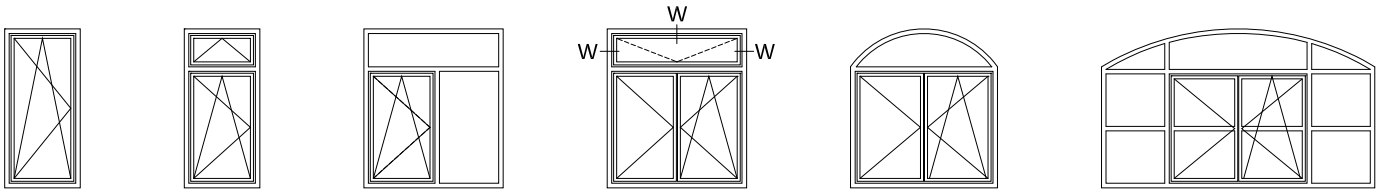

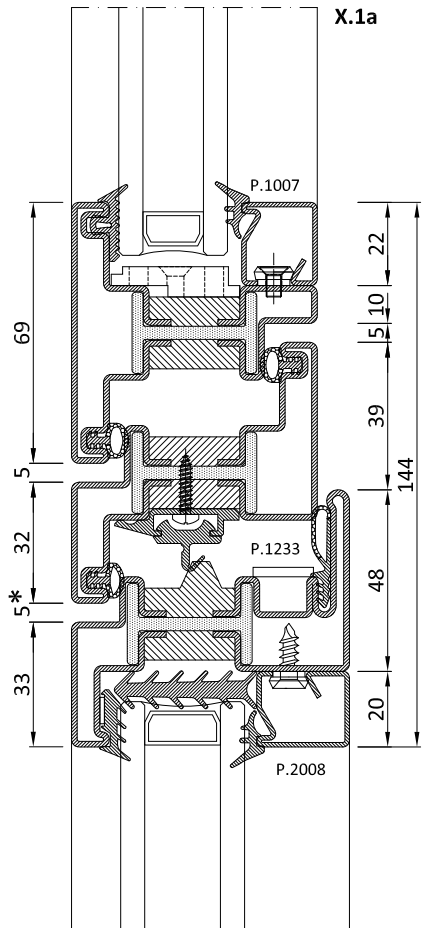
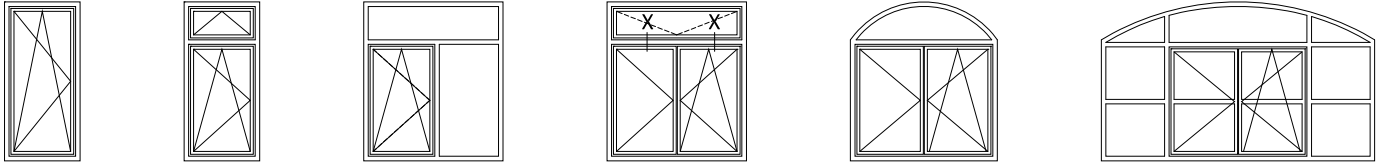

\* Vedi tabella 4.1.5  
\* See chart 4.1.5

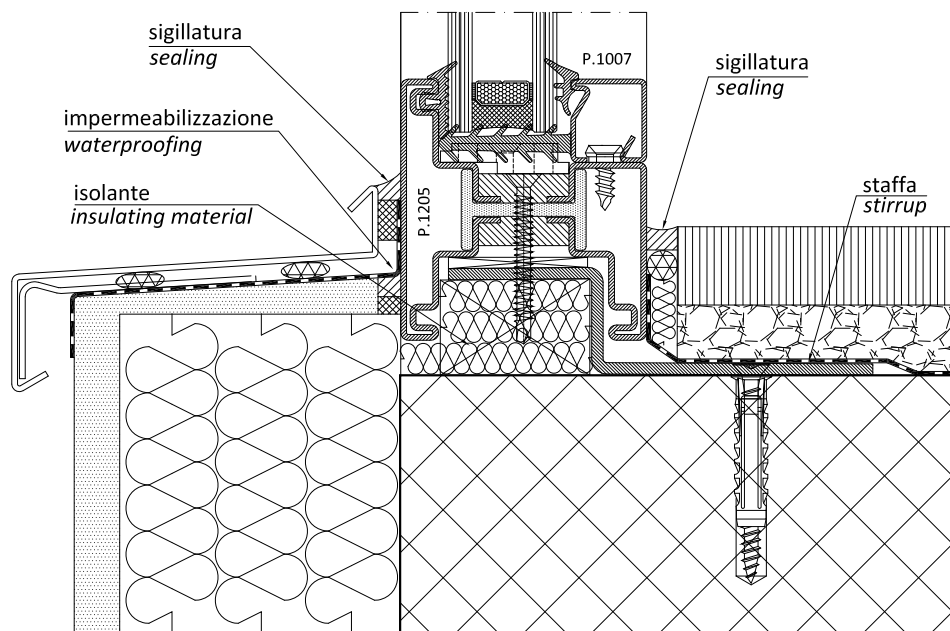
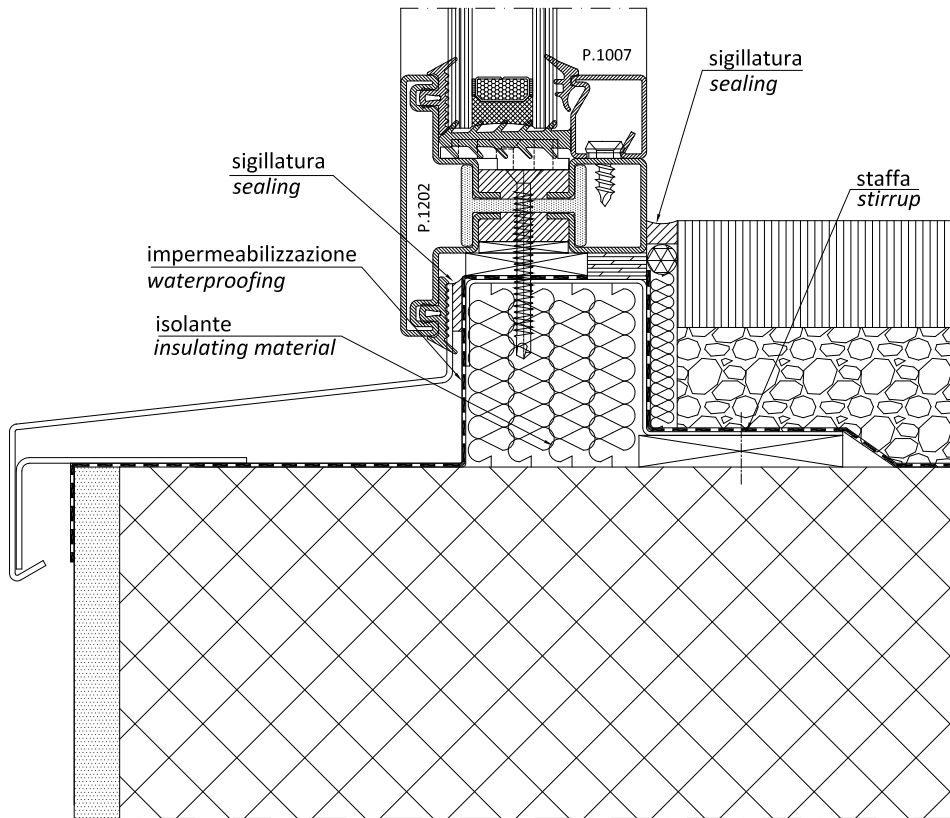

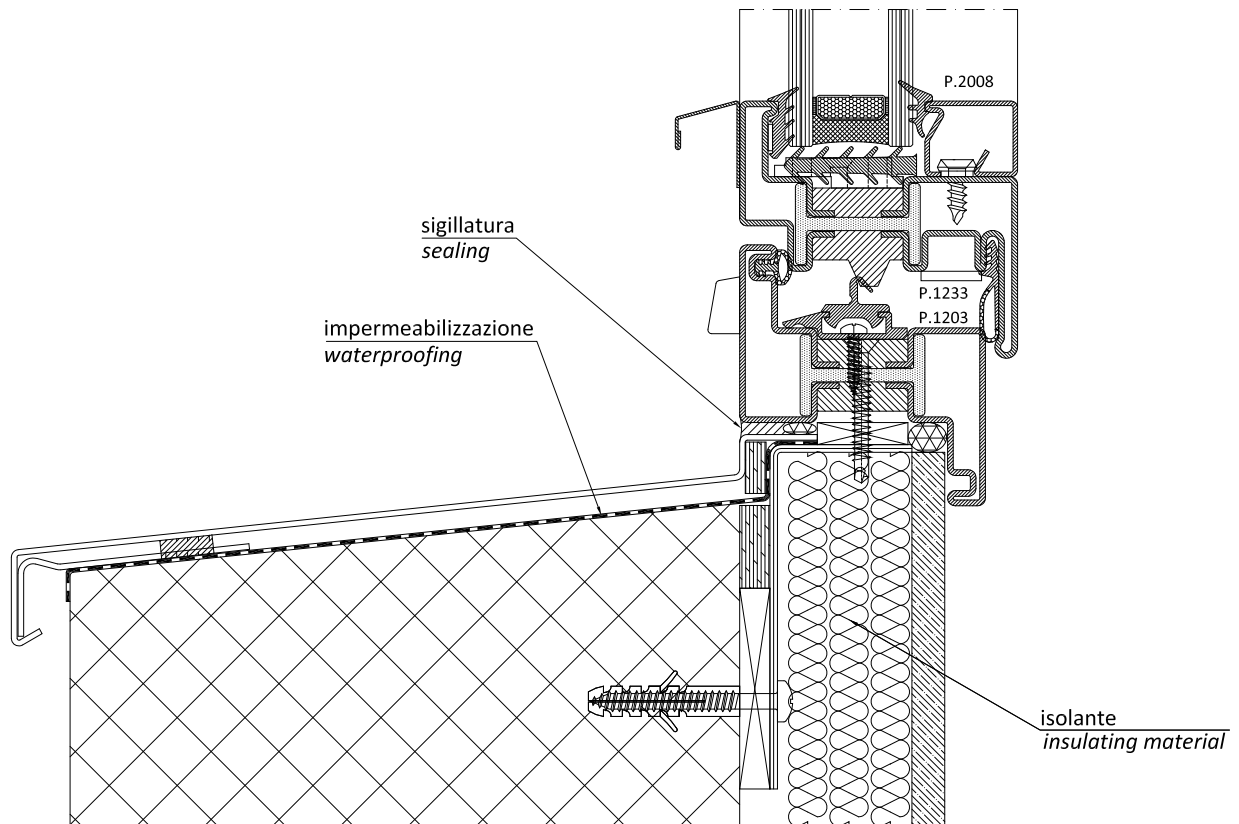
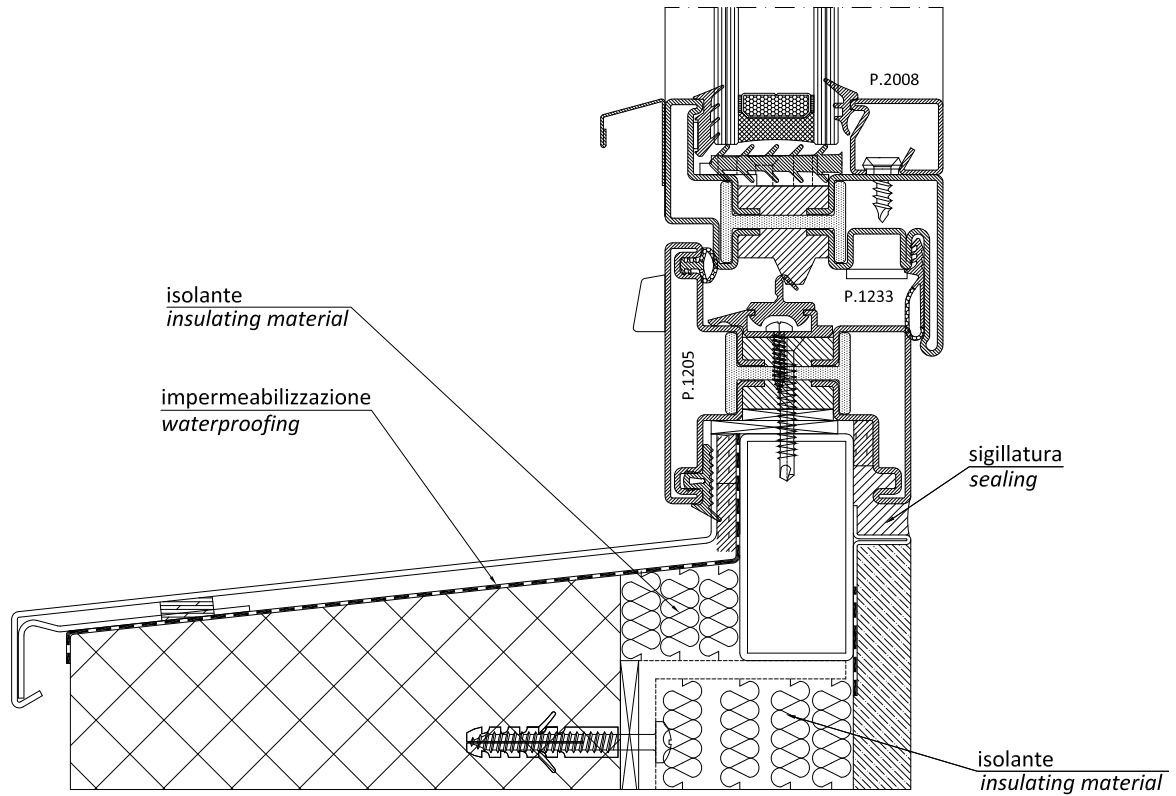



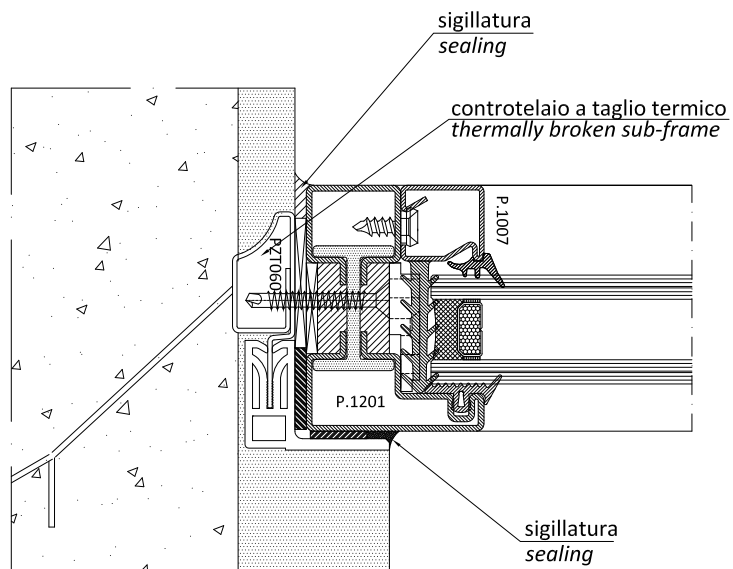
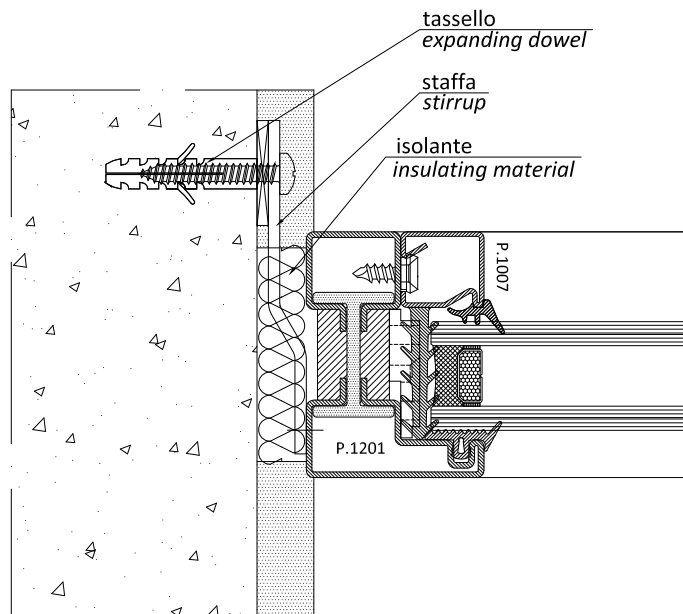
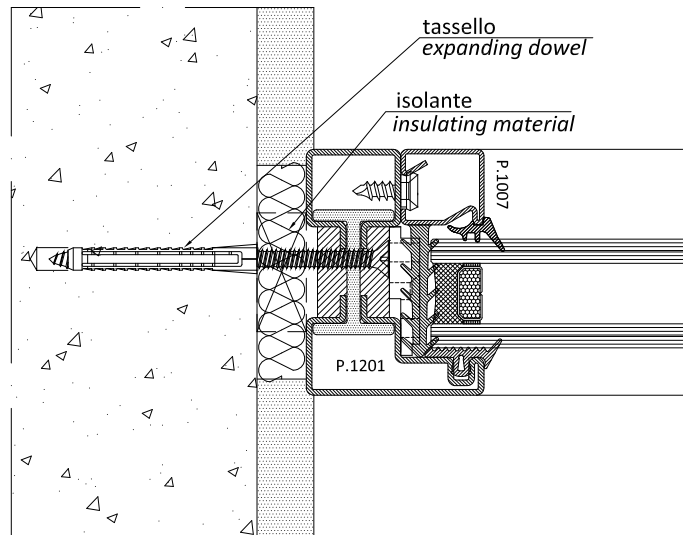

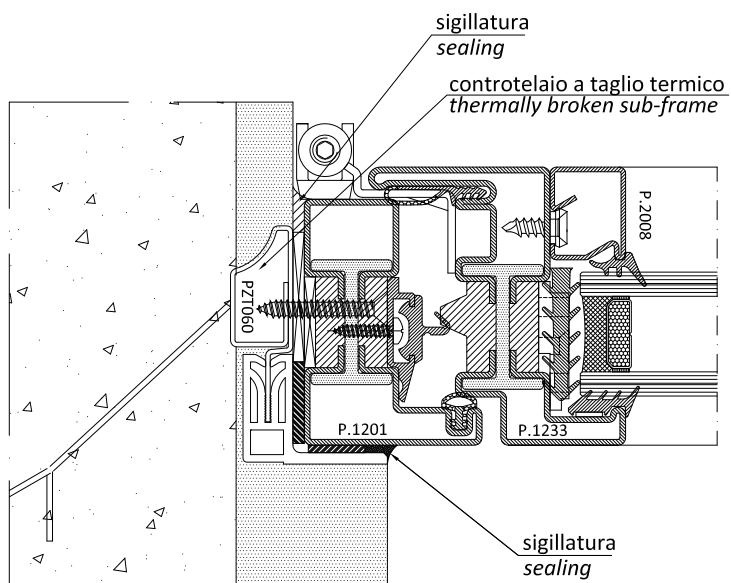
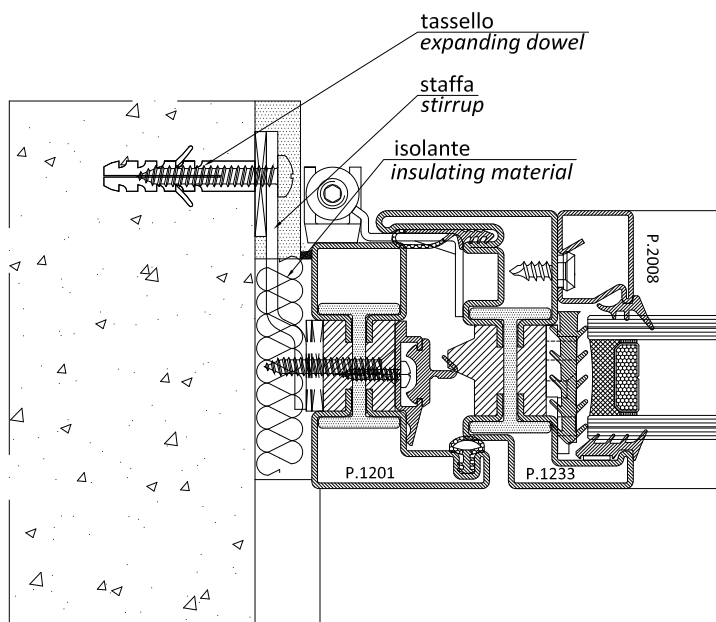
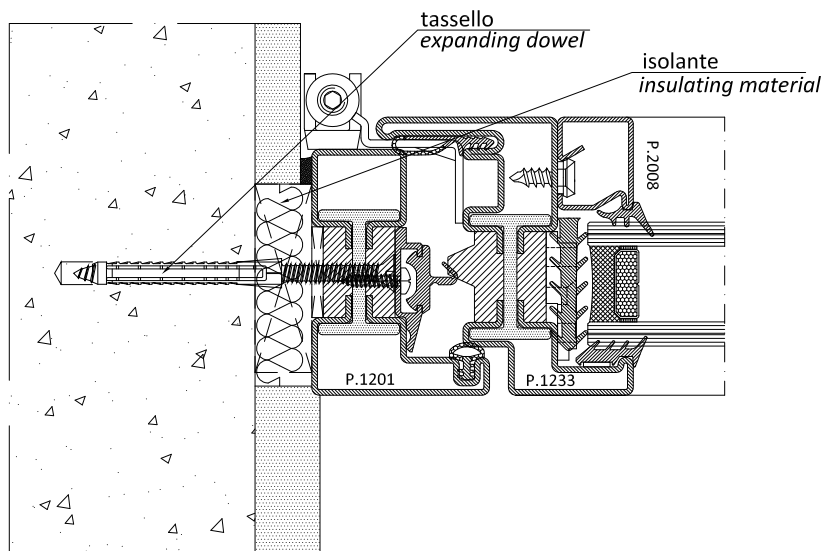

Applicare viti di fissaggio profilo a muro in corrispondenza dell'asse cerniere  
Apply anchoring screws to the hinge axis

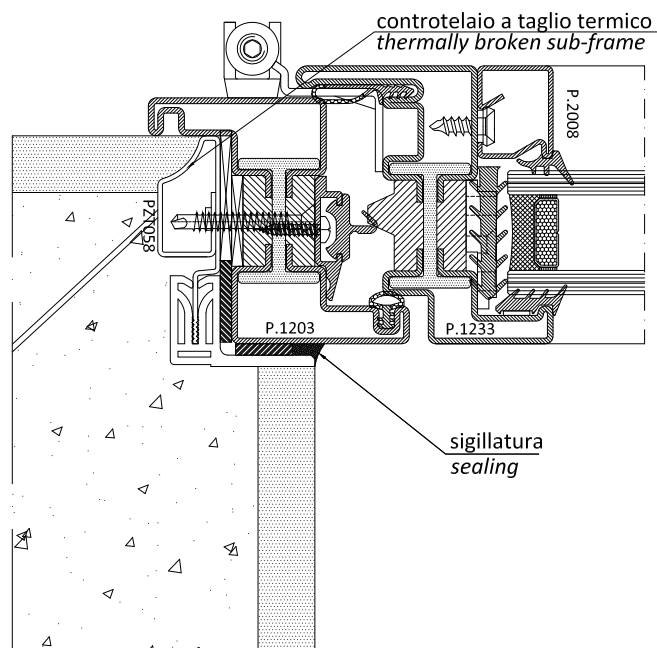
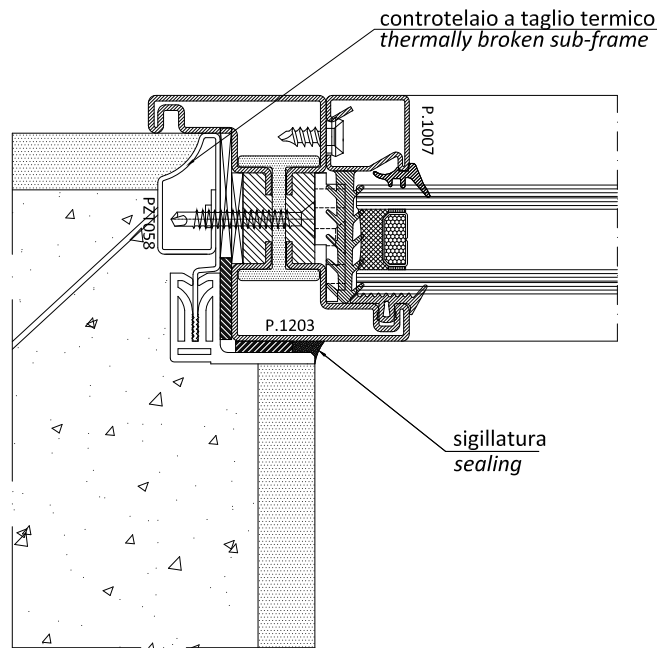

Applicare viti di fissaggio profilo a muro in corrispondenza dell'asse cerniere  
Apply anchoring screws to the hinge axis

**Distinta di taglio e lista componenti | Cutting list and components list**

Le distinte di taglio e le liste accessori individuate per le diverse tipologie sono state redatte per un serramento tipo.

E' compito dei tecnici specializzati delle ditte produttrici analizzare criticamente tali indicazioni al fine di verificare la compatibilità del tipo e numero di accessori previsti con il serramento oggetto della commessa reale.

*The cutting and hardware lists, which have been identified for the different typologies, have been produced for a standard window.*

*The specialized technicians of the window manufacturers will have to critically analyze such information in order to verify the compatibility of both the type and the number of accessories provided with the window object of the real order.*

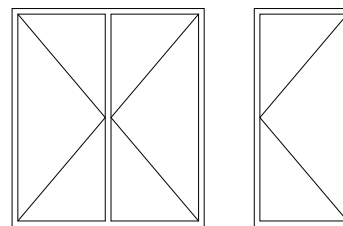

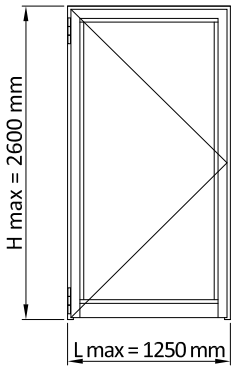

PROFILI		PROFILES			
Cod.	Descrizione	Description	n°	Dim.	Taglio Cutting
<b>Telaio</b>			<b>Frame</b>		
P.1011	Profilo a "L" telaio	"L" profile frame	1	LS	45° 45°
P.1011	Profilo a "L" telaio	"L" profile frame	1	HS	45° 90°
P.1011	Profilo a "L" telaio	"L" profile frame	1	HS	90° 45°
<b>Anta</b>			<b>Leaf</b>		
P.1013	Profilo a "Z" anta	"Z" profile leaf	1	LS-80	45° 45°
P.1013	Profilo a "Z" anta	"Z" profile leaf	1	HS-45	45° 90°
P.1013	Profilo a "Z" anta	"Z" profile leaf	1	HS-45	90° 45°
P.1005	Profilo zoccolo	Socle profile	1	LS-224	90° 90°
<b>Fermavetri</b>			<b>Glazing beads</b>		
P.1007	Fermavetro	Glazing bead profile	2	LS-224	90° 90°
P.1007	Fermavetro	Glazing bead profile	2	HS-233	90° 90°
<b>Vetri</b>			<b>Glass unit</b>		
-	Vetrocamera	Insulated glass	1	LS-240 x HS-205	
<b>ACCESSORI</b>			<b>HARDWARE</b>		
Cod.	Descrizione	Description	n°		
AC1004 *	Kit squadrette per P.1611	Corner joint kit for P.1611	2		
AC1007 *	Kit squadrette per P.1613	Corner joint kit for P.1613	2		
AC1021*	Cavallotto per P.1605	Butt joint kit P.1605	2		
AC1020 ..	Supporto spessore vetro	Glass support	6		
AC1033 ..	Cerniera a stilo	Road hinges	Var.		
AC1065/6/7..	Serratura multipunto	Multi-point lock	1		
AC1081/..	Paraspiffero automatico	Authomatic door seal	1		
ACV9...	Maniglia "Vitruvio"	"Vitruvio" handle	1		
CV5001(i)	Vite per boccola fermavetro	Screw for glazing bead bushing	Var.		
CV5012(i)	Boccola per fermavetro	Bushing for glazing bead	Var.		
<b>GUARNIZIONI</b>			<b>GASKETS</b>		
Cod.	Descrizione	Description	n°	Dim.	
GE1001TT	Guarnizione esterna di battuta	Rebating gasket	1	2xLS+4xHS	
GE1006	Guarnizione esterna vetro	External gasket	1	2xLS+2xHS	
GE1007TT	Guarnizione sottovetro	Gasket to put under the glass	1	2xLS+2xHS	
GE..	Guarnizione interna vetro	Internal gasket	1	2xLS+2xHS	

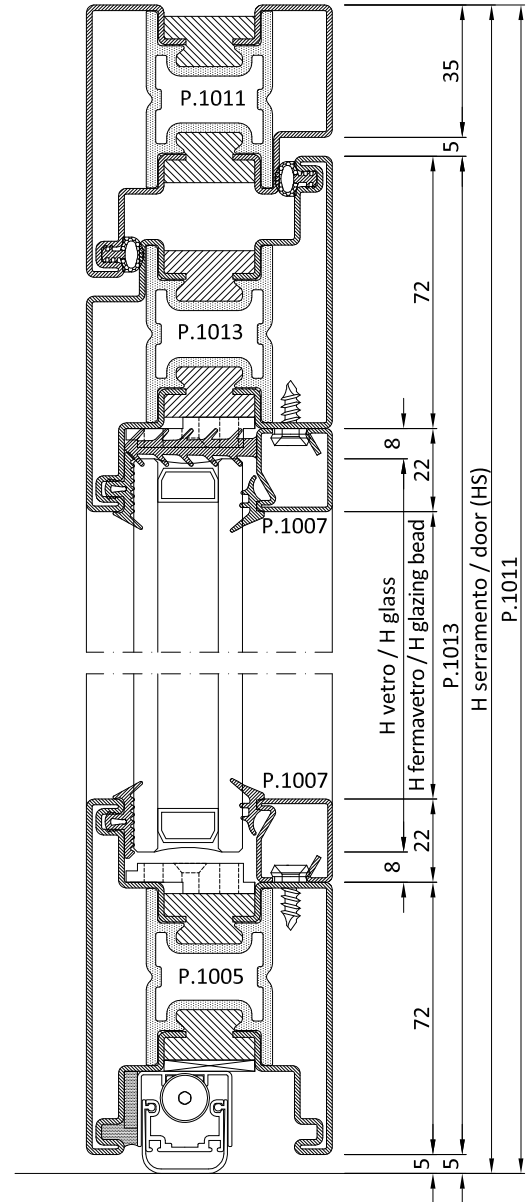

\* solo con profili ottone  
only with brass profiles

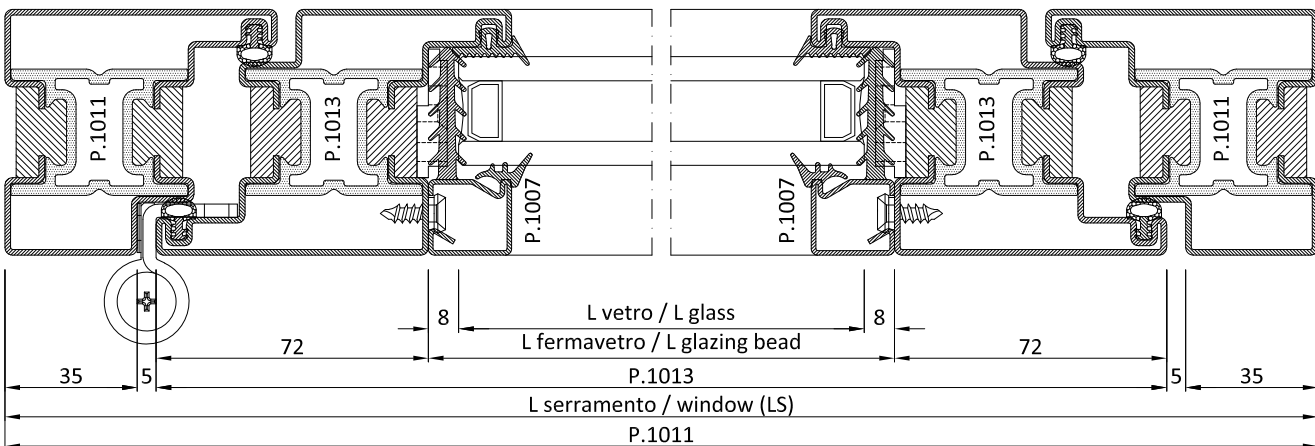

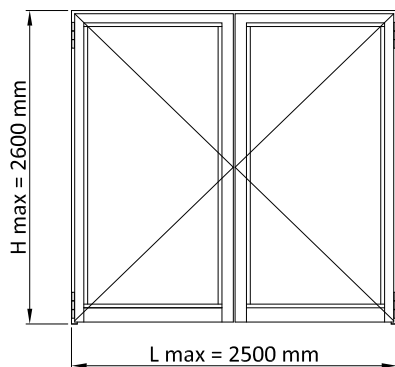

PROFILI		PROFILES				
Cod.	Descrizione	Description	n°	Dim.	Taglio	Cutting
<b>Telaio</b>		<b>Frame</b>				
P.1011	Profilo a "L" telaio	"L" profile frame	1	LS	45°	45°
P.1011	Profilo a "L" telaio	"L" profile frame	1	HS	45°	90°
P.1011	Profilo a "L" telaio	"L" profile frame	1	HS	90°	45°
<b>Anta</b>		<b>Leaf</b>				
P.1013	Profilo a "Z" anta	"Z" profile leaf	2	(LS-48)/2	45°	45°
P.1013	Profilo a "Z" anta	"Z" profile leaf	2	HS-45	45°	90°
P.1013	Profilo a "Z" anta	"Z" profile leaf	1	HS-45	90°	45°
P.1012	Profilo a "T" anta	"T" profile leaf	1	HS-45	90°	45°
P.1005	Profilo zoccolo	Socle profile	2	(LS-336)/2	90°	90°
<b>Fermavetri</b>		<b>Glazing beads</b>				
P.1007	Fermavetro	Glazing bead profile	4	(LS-336)/2	90°	90°
P.1007	Fermavetro	Glazing bead profile	4	HS-233	90°	90°
<b>Vetri</b>		<b>Glass unit</b>				
-	Vetrocamera	Insulated glass	2	(LS-368)/2 x HS-205		

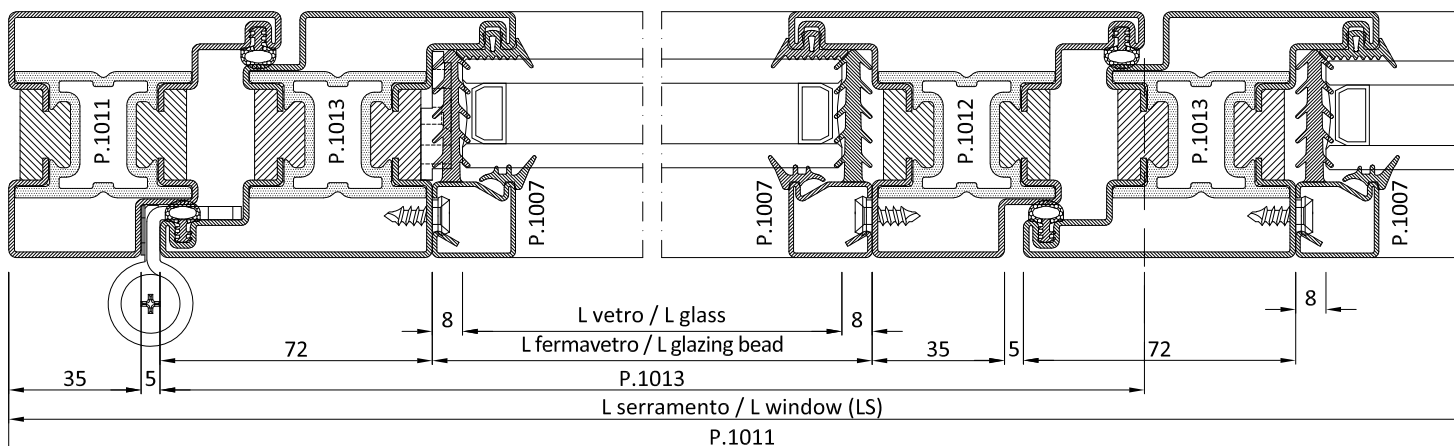

ACCESSORI		HARDWARE	
Cod.	Descrizione	Description	n°
AC1004*	Kit squadrette per P.1011	Corner joint kit for P.1011	2
AC1007*	Kit squadrette per P.1013	Corner joint kit for P.1013	3
AC1008*	Kit squadrette per P.1012-13	Corner joint kit for P.1012-13	1
AC1021*	Cavallotto per P.1005	Butt joint kit P.1005	4
AC1014	Fondino inversione battuta	Steel ending cap for reverting rebate	2
AC1020 ..	Supporto spessore vetro	Glass support	12
AC1033 ..	Cerniera a stilo	Road hinges	Var.
AC1040	Kit catenaccio 2 <sup>a</sup> anta	Kit for closing second leaf	1
AC1065/6/7..	Serratura multipunto	Multi-point lock	1
AC1081/..	Paraspiffero automatico	Authomatic door seal	2
ACV9...	Maniglia "Vitruvio"	"Vitruvio" handle	1
CV5001(i)	Vite per boccola fermavetro	Screw for glazing bead bushing	Var.
CV5012(i)	Boccola per fermavetro	Bushing for glazing bead	Var.

GUARNIZIONI		GASKETS	
Cod.	Descrizione	Description	n° Dim.
GE1001TT	Guarnizione esterna di battuta	Rebating gasket	1 2xLS+6xHS
GE1006	Guarnizione esterna vetro	External gasket	1 2xLS+4xHS
GE1007TT	Guarnizione sottovetro	Gasket to put under the glass	1 2xLS+4xHS
GE..	Guarnizione interna vetro	Internal gasket	1 2xLS+4xHS

\* solo con profili ottone  
only with brass profiles

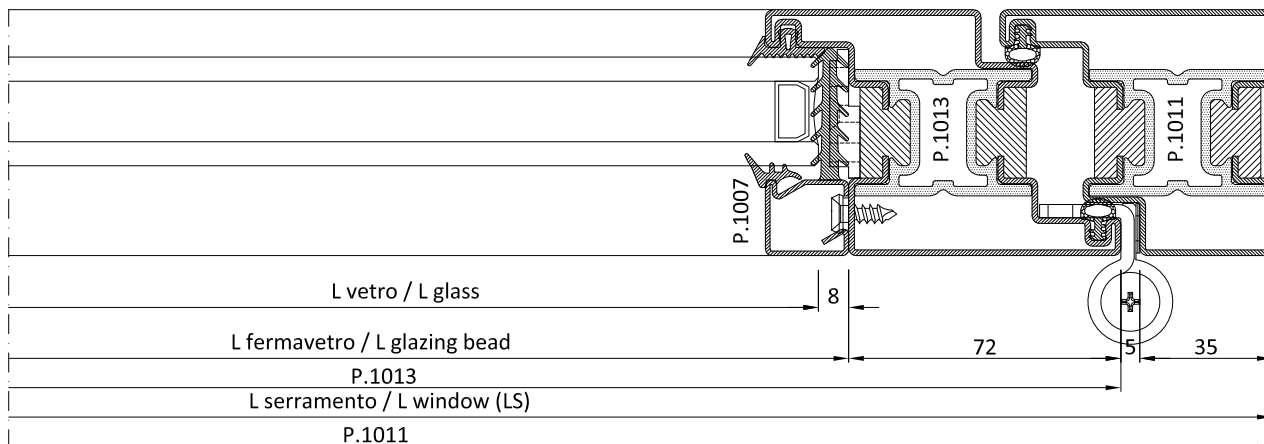
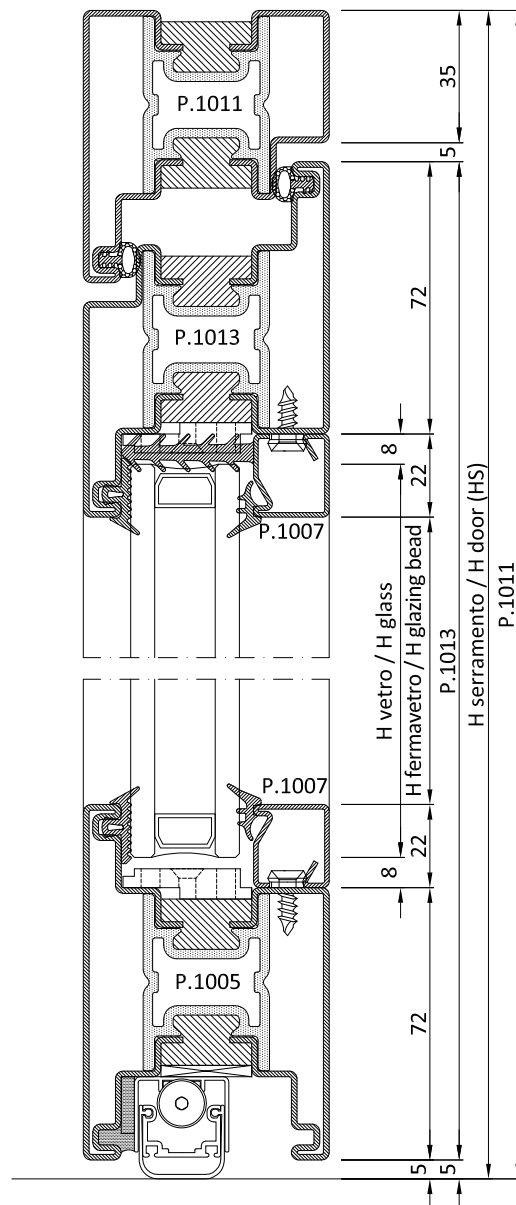

**Distinta di taglio e lista componenti | Cutting list and components list**

Le distinte di taglio e le liste accessori individuate per le diverse tipologie sono state redatte per un serramento tipo.  
E' compito dei tecnici specializzati delle ditte produttrici analizzare criticamente tali indicazioni al fine di verificare la compatibilità del tipo e numero di accessori previsti con il serramento oggetto della commessa reale.

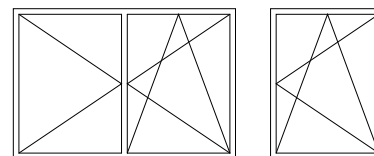

*The cutting and hardware lists, which have been identified for the different typologies, have been produced for a standard window.  
The specialized technicians of the window manufacturers will have to critically analyze such information in order to verify the compatibility of both the type and the number of accessories provided with the window object of the real order.*

**La tabella seguente va attentamente letta prima del taglio dei profili | The following table should be carefully read before the profiles cutting**

In essa è riportata la misura da considerare nella distanza tra telaio anta e telaio fisso nella produzione di finestre in funzione della tipologia, del tipo di cerniera e della larghezza delle ante da produrre.

*It shows the measurement to follow between the leaf and the fixed frame in the production of windows depending on the typology, the hinge type and the width of the leaf to be produced.*

			larghezza anta (cava ferramenta in mm) leaf width (hardware slot in mm)				
			280 360	361 480	481 600	601 800	> 800
AR Easy DK Easy	AGE 271(2) AGE 271(2)-276(5) AGE 291(2) AGE 291(2)-296(5)	aria - gap	6	6	5	5	5
		riscontro - strike	std	std	std	std	std
	AGE 281(2) AGE 281(2)-286(5) AGE 281(2)-786(5)	aria - gap	-	5,5	5,5	5,5	5,5
		riscontro - strike	-	std	std	std	std
	AGE 271(2)-776(5) AGE 291(2)-796(5)	aria - gap	6	6	5	5	5
		riscontro - strike	std	std	std	std	std
AG 1273 AG 1278		aria - gap	6	6	5	5	5
		riscontro - strike	std	std	std	std	std
AR Easy DK RC2	AG 1271(2) AG 1271(2)-276(5) AG 1291(2) AG 1291(2)-296(5)	aria - gap	-	-	5	5	5
		riscontro - strike	-	-	std	std	std
	AG 1281(2) AG 1281(2)-286(5)	aria - gap	-	-	5,5	5,5	5,5
		riscontro - strike	-	-	std	std	std
Anta Casement	AGA 271 AGA 271-275 AGA 271-775	aria - gap	6	6	5	5	5
		riscontro - strike	std	std	std	std	std

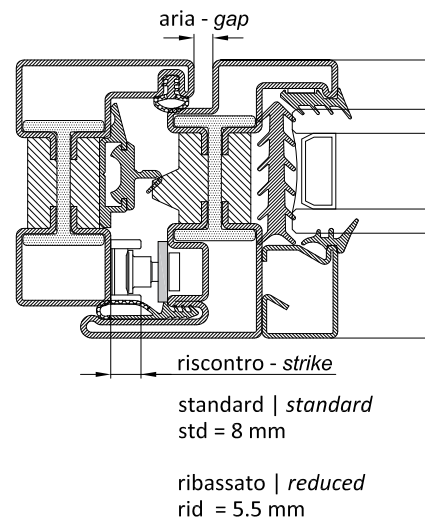

**NB**  
gli incontri ribassati devono essere installati solamente sul lato cremonese  
*reduced strikes should be installed only on cremone vertical side*



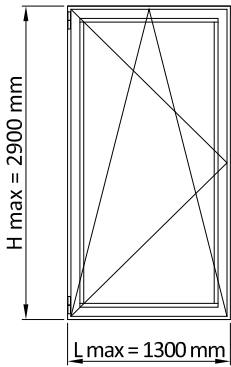

PROFILI		PROFILES				
Cod.	Descrizione	Description	n°	Dim.	Taglio	Cutting
<b>Telaio</b>						
<b>Frame</b>						
P.1203	Profilo a "Z" telaio	"Z" profile frame	2	LS+44	45°	45°
P.1203	Profilo a "Z" telaio	"Z" profile frame	2	HS+44	45°	45°
<b>Anta</b>						
<b>Leaf</b>						
P.1233	Profilo a "Z" anta	"Z" profile frame	2	LS-34	45°	45°
P.1233	Profilo a "Z" anta	"Z" profile frame	2	HS-34	45°	45°
P.2027	Profilo battiacqua	Water drip profile	2	LS-104	90°	90°
<b>Fermavetri</b>						
<b>Glazing beads</b>						
P.2008	Fermavetro	Glazing bead profile	2	LS-130	90°	90°
P.2008	Fermavetro	Glazing bead profile	2	HS-170	90°	90°
<b>Vetri</b>						
<b>Glass unit</b>						
-	Vetrocamera	Insulated glass	1	LS-146 x HS-146		

ACCESSORI		HARDWARE	
Cod.	Descrizione	Description	n°
AC12031**	Kit squadrette per P.1203	Corner joint kit for P.1203	4
AC12071**	Kit squadrette per P.1233	Corner joint kit for P.1233	4
AC1716	Guarnizione d'angolo	Vulcanised corner gasket	4
AC1219	Scarico acqua	Water drip	Var.
AGE271/2..	Meccanismo Anta Ribalta	Tilt and Turn mechanism	1
AG1271/C	Kit copertine plastica	Kit of RH plastic	1
ACV97..	Maniglia "Vitruvio"	"Vitruvio" handle	1
AC1356	Meccanismo DK	External tilt & turn mechanism	1
AC1020	Supporto spessore vetro	Glass support	6
CV5001(i)	Vite per boccola fermavetro	Screw for glazing bead bushing	Var.
CV5012(i)	Boccola per fermavetro	Bushing for glazing bead	Var.

GUARNIZIONI		GASKETS	
Cod.	Descrizione	Description	n°
GE1233TT	Guarnizione esterna di battuta	External rebating gasket	1
GE1701	Guarnizione giunto aperto	Open joint system gasket	1
GU1702	Estruso PVC giunto aperto	Open joint system PVC profile	1
GE1200TT	Guarnizione interna di battuta	Internal rebating gasket	1
GE1206	Guarnizione esterna vetro	External gasket	1
GE1007TT	Guarnizione sottovetro	Gasket to put under the glass	1
GE..	Guarnizione interna vetro	Internal gasket	1

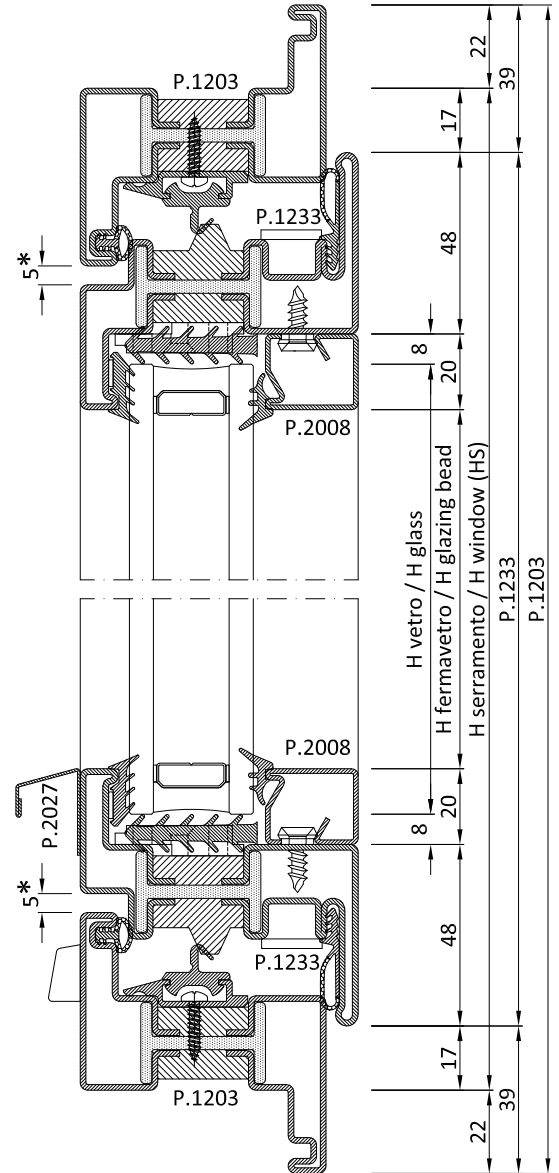

\* vedi tabella 4.1.5  
see chart 4.1.5

\*\* solo con profili ottone  
only with brass profiles

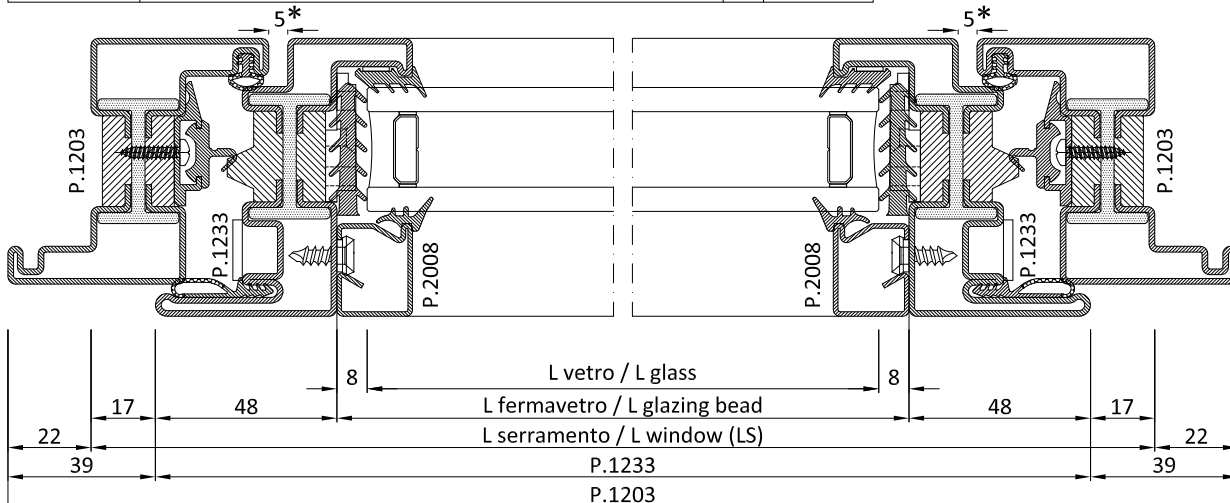

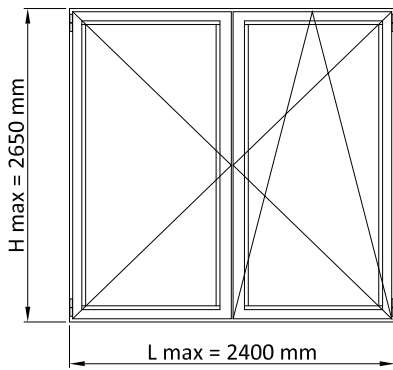

PROFILI		PROFILES				
Cod.	Descrizione	Description	n°	Dim.	Taglio	Cutting
<b>Telaio</b>		<b>Frame</b>				
P.1203	Profilo a "Z" telaio	"Z" profile frame	2	LS+44	45°	45°
P.1203	Profilo a "Z" telaio	"Z" profile frame	2	HS+44	45°	45°
<b>Anta</b>		<b>Leaf</b>				
P.1233	Profilo a "Z" anta	"Z" profile frame	4	(LS-43)/2	45°	45°
P.1233	Profilo a "Z" anta	"Z" profile frame	4	HS-34	45°	45°
P.1202	Profilo a "T" anta	"T" profile frame	1	HS-82.5	90°	90°
P.2027	Profilo battiacqua	Water drip profile	2	(LS-183)/2	90°	90°
<b>Fermavetri</b>		<b>Glazing beads</b>				
P.2008	Fermavetro	Glazing bead profile	4	(LS-235)/2	90°	90°
P.2008	Fermavetro	Glazing bead profile	4	HS-170	90°	90°
<b>Vetri</b>		<b>Glass unit</b>				
-	Vetrocamera	Insulated glass	2	[(LS-267)/2] x HS-146		

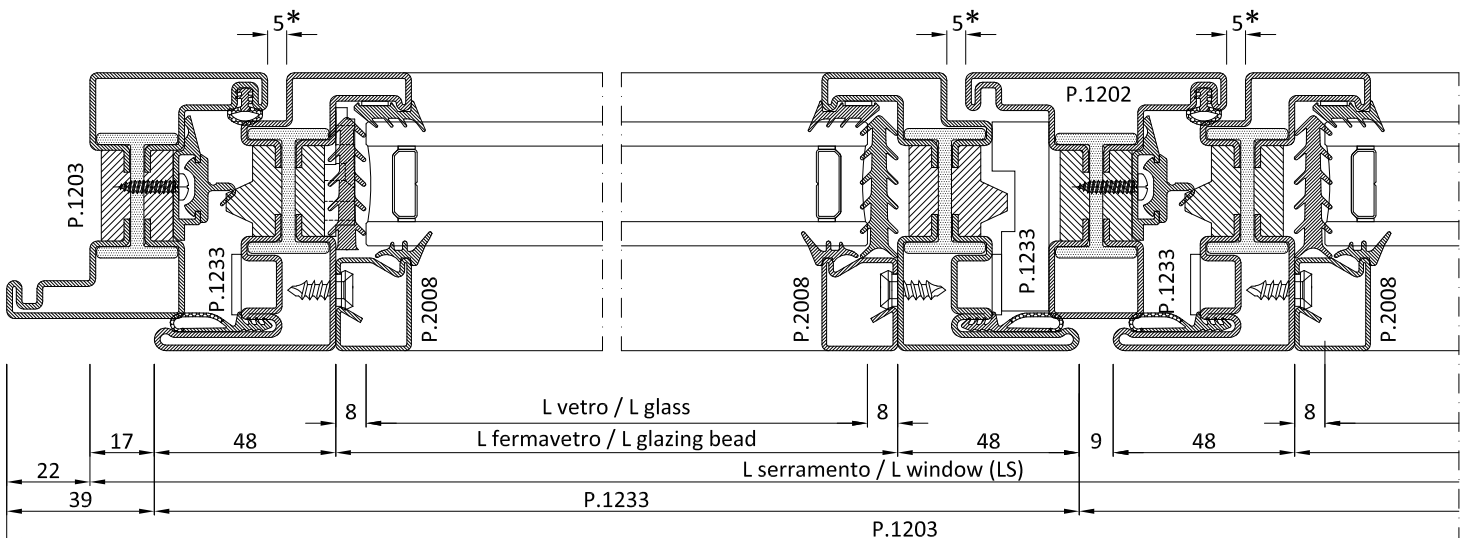

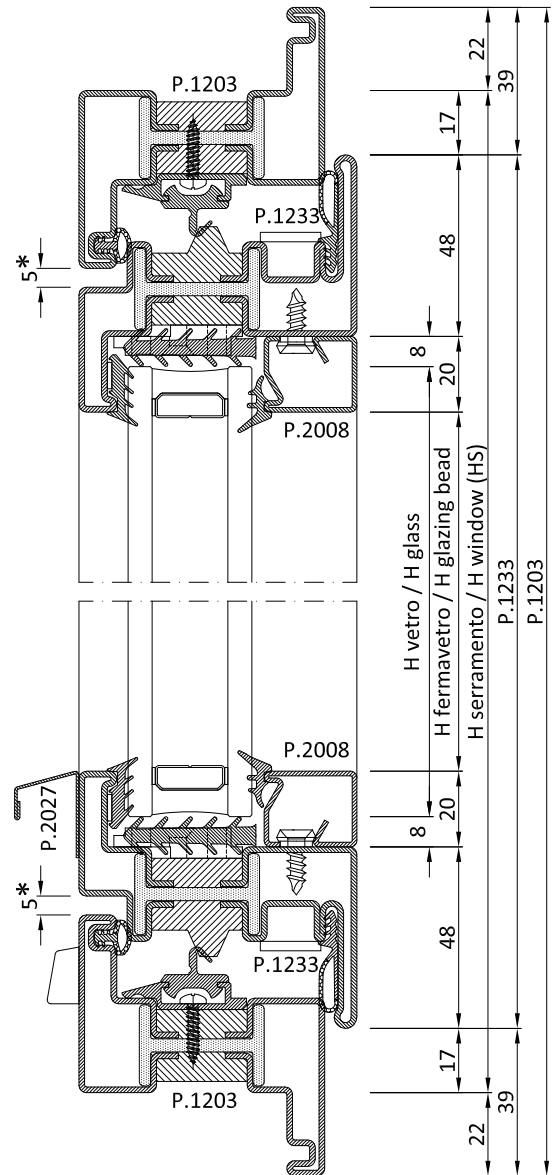

ACCESSORI		HARDWARE	
Cod.	Descrizione	Description	n°
AC12031**	Kit squadrette per P.1203	Corner joint kit for P.1203	4
AC12071**	Kit squadrette per P.1233	Corner joint kit for P.1233	8
AC1215	Kit inversione battuta 2ª anta	2nd leaf reverse closure kit	2
AC1716	Guarnizione d'angolo	Vulcanised corner gasket	4
AC1219	Scarico acqua	Water drip	Var.
AGE271/2..	Meccanismo Anta Ribalta 1ª anta	1st leaf tilt/turn mechanism	1
AGE275/6..	Meccanismo Anta Ribalta 2ª anta	2nd leaf tilt/turn mechanism	1
AG1271/C	Kit copertine plastica - dx	Kit of RH plastic - right	1
AG1272/C	Kit copertine plastica - dx	Kit of RH plastic - left	1
ACV97..	Maniglia "Vitruvio"	"Vitruvio" handle	1
AC1356	Meccanismo DK	External tilt & turn mechanism	1
AC1020	Supporto spessore vetro	Glass support	12
CV5001(i)	Vite per boccola fermavetro	Screw for glazing bead bushing	Var.
CV5012(i)	Boccola per fermavetro	Bushing for glazing bead	Var.

GUARNIZIONI		GASKETS	
Cod.	Descrizione	Description	n° Dim.
GE1233TT	Guarnizione esterna di battuta	External rebating gasket	1 2xLS+4xHS
GE1701	Guarnizione giunto aperto	Open joint system gasket	1 2xLS+3xHS
GU1702	Estruso PVC giunto aperto	Open joint system PVC profile	1 2xLS+3xHS
GE1200TT	Guarnizione interna di battuta	Internal rebating gasket	1 2xLS+4xHS
GE1206	Guarnizione esterna vetro	External gasket	1 2xLS+4xHS
GE1007TT	Guarnizione sottovetro	Gasket to put under the glass	1 2xLS+4xHS
GE..	Guarnizione interna vetro	Internal gasket	1 2xLS+4xHS

\* vedi tabella 4.1.5  
see chart 4.1.5

\*\* solo con profili ottone  
only with brass profiles

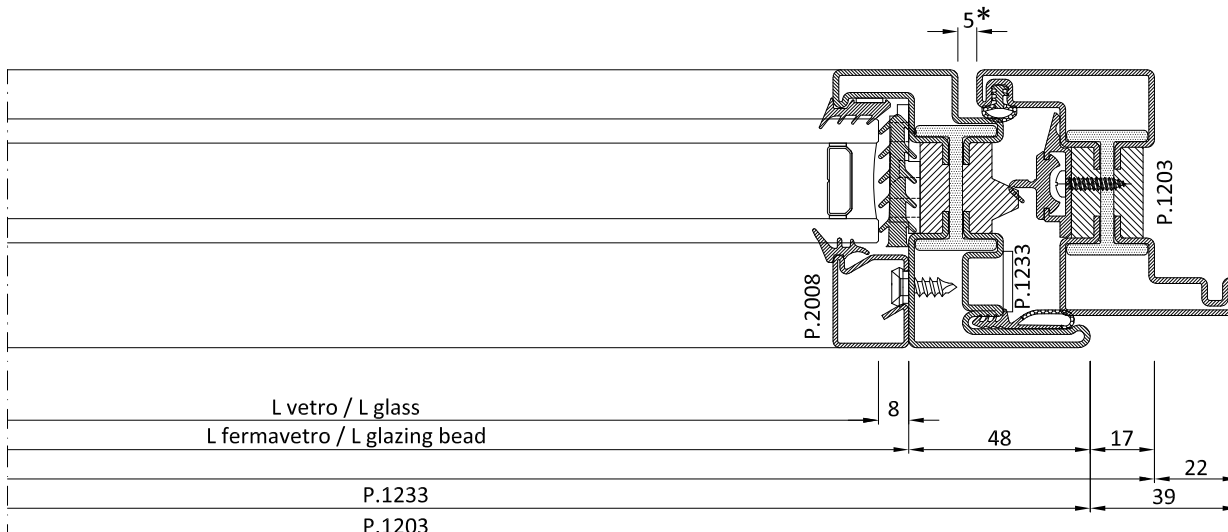

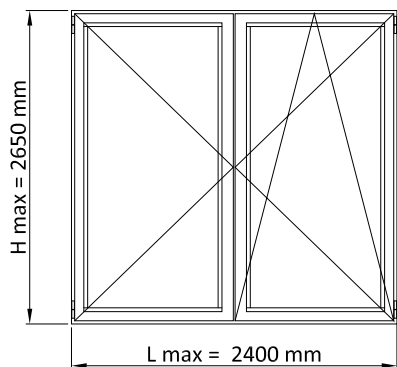

PROFILI		PROFILES				
Cod.	Descrizione	Description	n°	Dim.	Taglio	Cutting
<b>Telaio</b>		<b>Frame</b>				
P.1203	Profilo a "Z" telaio	"Z" profile frame	2	LS+44	45°	45°
P.1203	Profilo a "Z" telaio	"Z" profile frame	2	HS+44	45°	45°
<b>Anta</b>		<b>Leaf</b>				
P.1233	Profilo a "Z" anta	"Z" profile frame	4	(LS-5)/2	45°	45°
P.1233	Profilo a "Z" anta	"Z" profile frame	3	HS-34	45°	45°
P.1724	Profilo a "T" anta	"T" profile frame	1	HS-32	45°	45°
P.2027	Profilo battiacqua	Water drip profile	1	(LS-75)/2	90°	90°
P.2027	Profilo battiacqua	Water drip profile	2	(LS-143)/2	90°	90°
<b>Fermavetri</b>		<b>Glazing beads</b>				
P.2008	Fermavetro	Glazing bead profile	4	(LS-197)/2	90°	90°
P.2008	Fermavetro	Glazing bead profile	4	HS-170	90°	90°
<b>Vetri</b>		<b>Glass unit</b>				
-	Vetrocamera	Insulated glass	2	[(LS-229)/2] x HS-146		

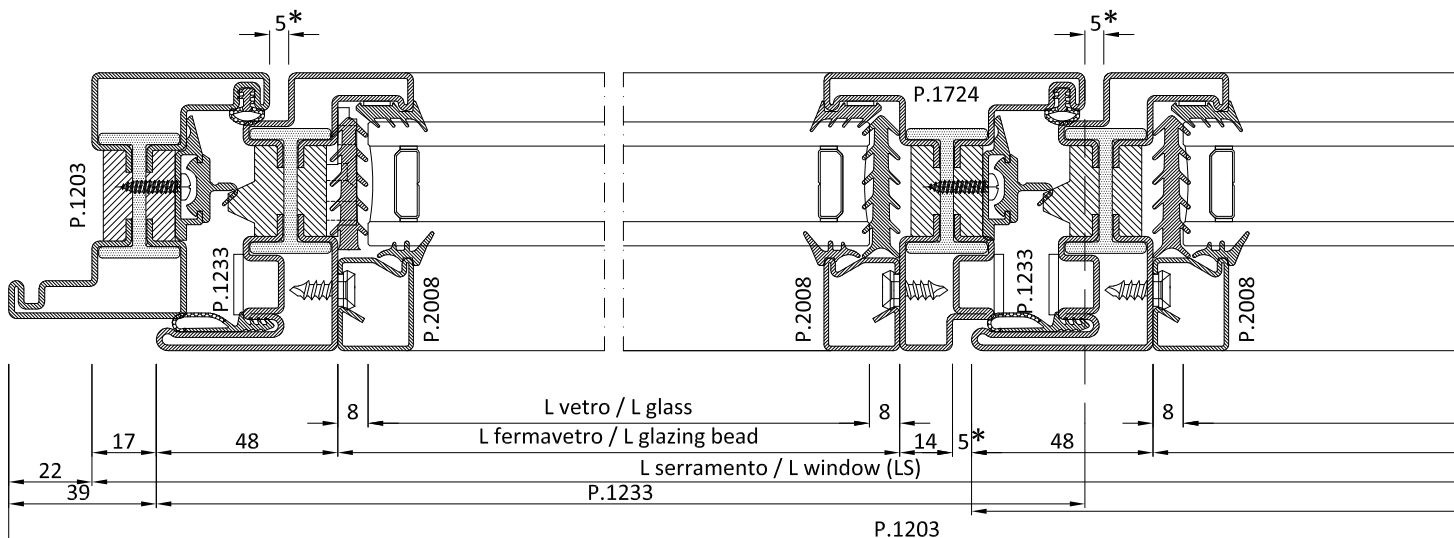

ACCESSORI		HARDWARE	
Cod.	Descrizione	Description	n°
AC12031**	Kit squadrette per P.1203	Corner joint kit for P.1203	4
AC12071**	Kit squadrette per P.1233	Corner joint kit for P.1233	6
AC17081**	Kit squadrette per P.1233-1724	Corner joint kit for P.1233-1724	2
AC1716	Guarnizione d'angolo	Vulcanised corner gasket	4
AC1219	Scarico acqua	Water drip	Var.
AC1714	Kit inversione battuta 2^ anta	2nd leaf reverse closure kit	1
AGE271/2..	Meccanismo Anta Ribalta 1^ anta	1st leaf tilt/turn mechanism	1
AGE775/6..	Meccanismo Anta Ribalta 2^ anta	2nd leaf tilt/turn mechanism	1
AG1271/C	Kit copertine plastica - dx	Kit of RH plastic - right	1
AG1272/C	Kit copertine plastica - dx	Kit of RH plastic - left	1
ACV97..	Maniglia "Vitruvio"	"Vitruvio" handle	1
AC1356	Meccanismo DK	External tilt & turn mechanism	1
AC1020	Supporto spessore vetro	Glass support	12
CV5001(i)	Vite per boccola fermavetro	Screw for glazing bead bushing	Var.
CV5012(i)	Boccola per fermavetro	Bushing for glazing bead	Var.

  

GUARNIZIONI		GASKETS		
Cod.	Descrizione	Description	n°	Dim.
GE1233TT	Guarnizione esterna di battuta	External rebating gasket	1	2xLS+3xHS
GE1701	Guarnizione giunto aperto	Open joint system gasket	1	2xLS+3xHS
GE1704	Guarnizione giunto aperto P.1724	Open joint system gasket P.1724	1	1xHS
GU1702	Estruso PVC giunto aperto	Open joint system PVC profile	1	2xLS+3xHS
GE1200TT	Guarnizione interna di battuta	Internal rebating gasket	1	2xLS+3xHS
GE1206	Guarnizione esterna vetro	External gasket	1	2xLS+4xHS
GE1007TT	Guarnizione sottovetro	Gasket to put under the glass	1	2xLS+4xHS
GE..	Guarnizione interna vetro	Internal gasket	1	2xLS+4xHS

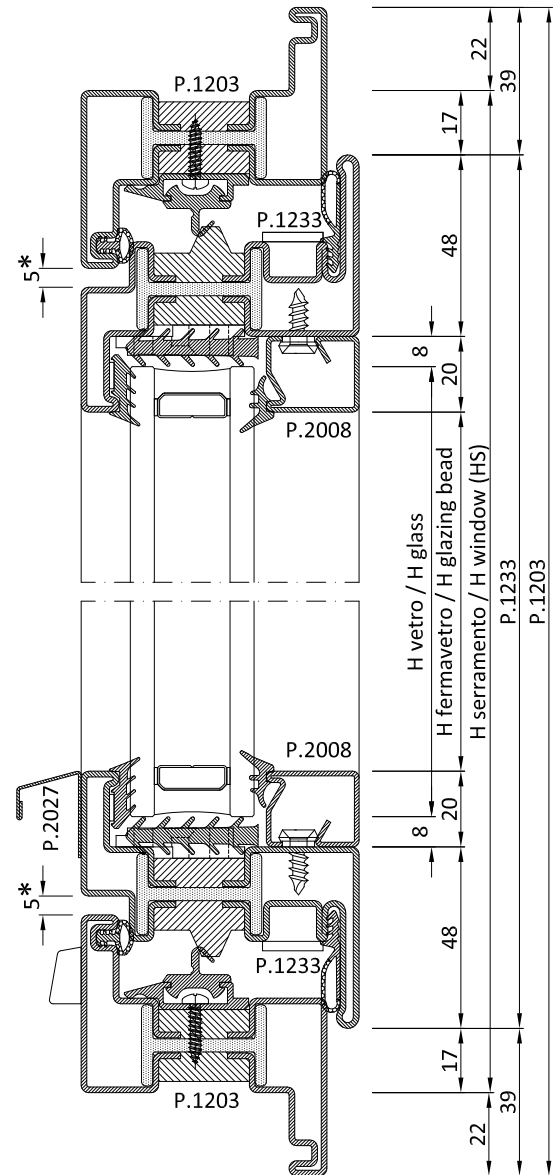

\* vedi tabella 4.1.5  
see chart 4.1.5

\*\* solo con profili ottone  
only with brass profiles

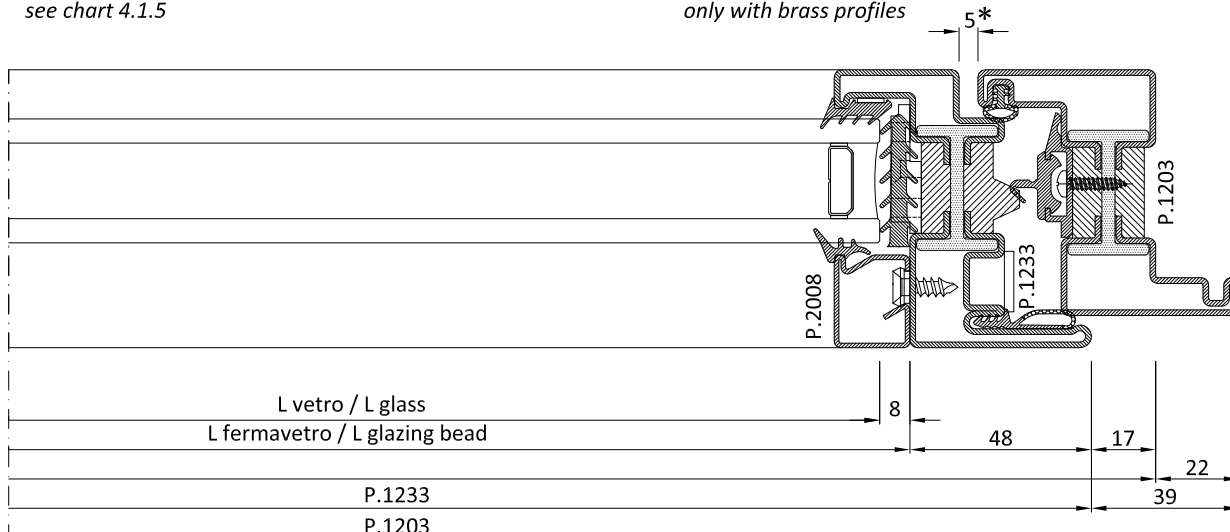

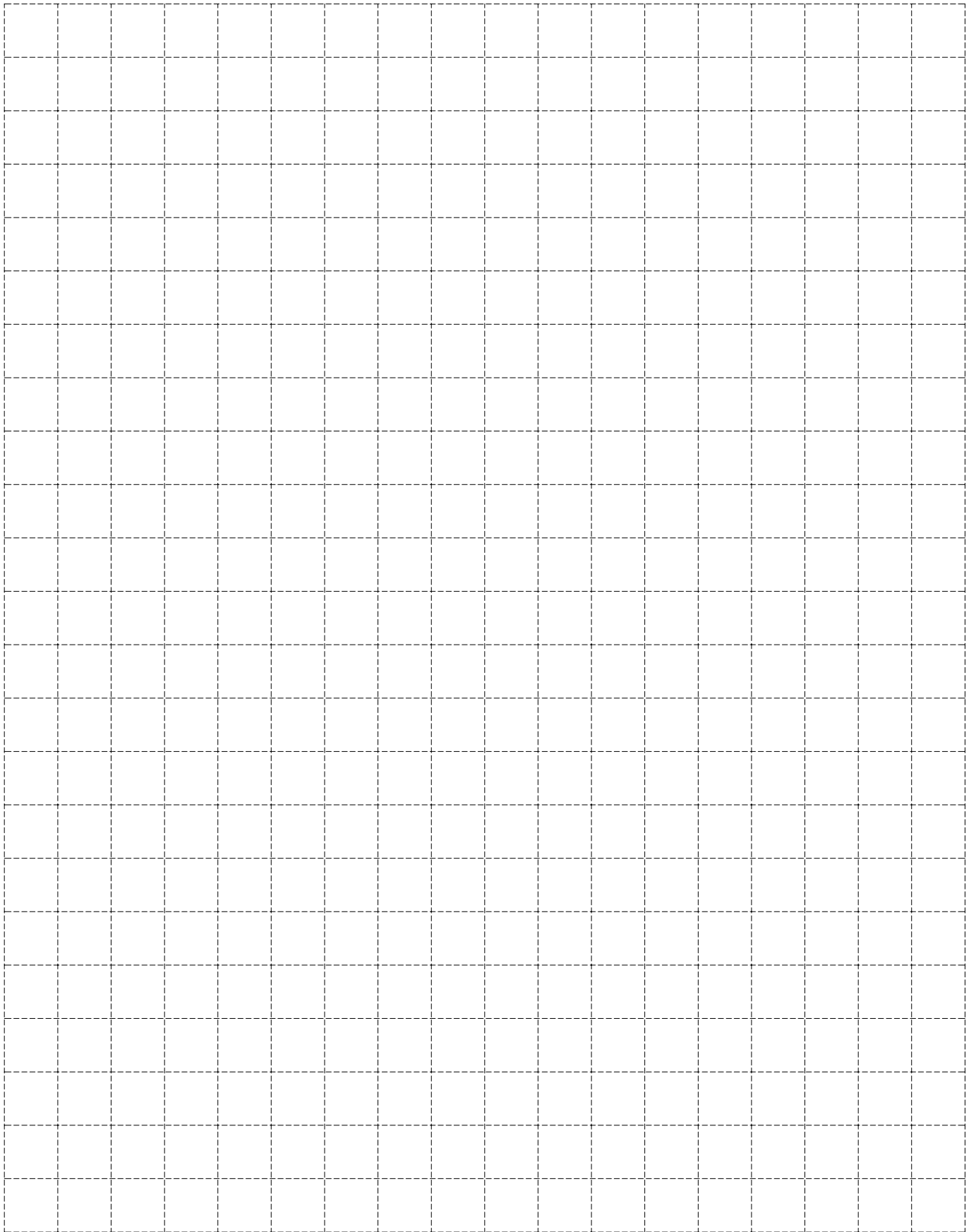

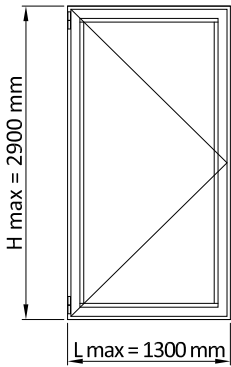

PROFILI		PROFILES			
Cod.	Descrizione	Description	n°	Dim.	Taglio Cutting
<b>Telaio</b> <i>Frame</i>					
P.1203	Profilo a "Z" telaio	"Z" profile frame	2	LS+44	45° 45°
P.1203	Profilo a "Z" telaio	"Z" profile frame	2	HS+44	45° 45°
<b>Anta</b> <i>Leaf</i>					
P.1233	Profilo a "Z" anta	"Z" profile frame	2	LS-34	45° 45°
P.1233	Profilo a "Z" anta	"Z" profile frame	2	HS-34	45° 45°
P.2027	Profilo battiacqua	Water drip profile	2	LS-104	90° 90°
<b>Fermavetri</b> <i>Glazing beads</i>					
P.2008	Fermavetro	Glazing bead profile	2	LS-130	90° 90°
P.2008	Fermavetro	Glazing bead profile	2	HS-170	90° 90°
<b>Vetri</b> <i>Glass unit</i>					
-	Vetrocamera	Insulated glass	1	LS-146 x HS-146	
<b>ACCESSORI</b> <i>HARDWARE</i>					
Cod.	Descrizione	Description	n°		
AC1203I**	Kit squadrette per P.1203	Corner joint kit for P.1203	4		
AC1207I**	Kit squadrette per P.1233	Corner joint kit for P.1233	4		
AC1716	Guarnizione d'angolo	Vulcanised corner gasket	4		
AC1219	Scarico acqua	Water drip	Var.		
AC1237	Cerniera ad avvitare	Screw-on hinge	Var.		
AGA271	Meccanismo apertura ad anta	Casement window mechanism	1		
ACV97..	Maniglia "Vitruvio"	"Vitruvio" handle	1		
AC1356	Meccanismo DK	External tilt & turn mechanism	1		
AC1020	Supporto spessore vetro	Glass support	6		
CV5001(i)	Vite per boccola fermavetro	Screw for glazing bead bushing	Var.		
CV5012(i)	Boccola per fermavetro	Bushing for glazing bead	Var.		
<b>GUARNIZIONI</b> <i>GASKETS</i>					
Cod.	Descrizione	Description	n°	Dim.	
GE1233TT	Guarnizione esterna di battuta	External rebating gasket	1	2xLS+2xHS	
GE1701	Guarnizione giunto aperto	Open joint system gasket	1	2xLS+2xHS	
GU1702	Estruso PVC giunto aperto	Open joint system PVC profile	1	2xLS+2xHS	
GE1200TT	Guarnizione interna di battuta	Internal rebating gasket	1	2xLS+2xHS	
GE1206	Guarnizione esterna vetro	External gasket	1	2xLS+2xHS	
GE1007TT	Guarnizione sottovetro	Gasket to put under the glass	1	2xLS+2xHS	
GE..	Guarnizione interna vetro	Internal gasket	1	2xLS+2xHS	

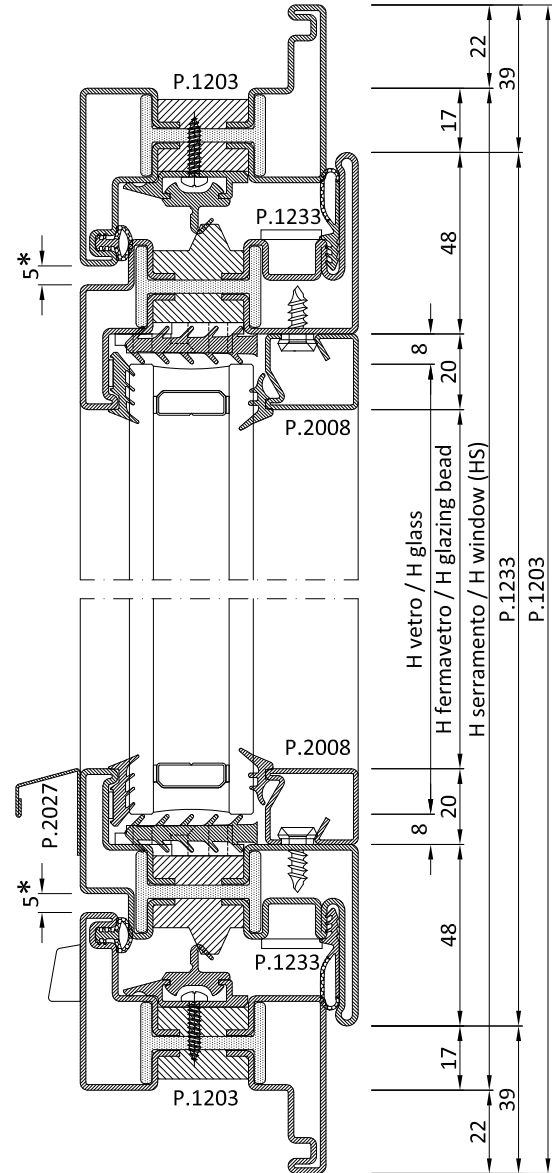

\* vedi tabella 4.1.5  
see chart 4.1.5

\*\* solo con profili ottone  
only with brass profiles

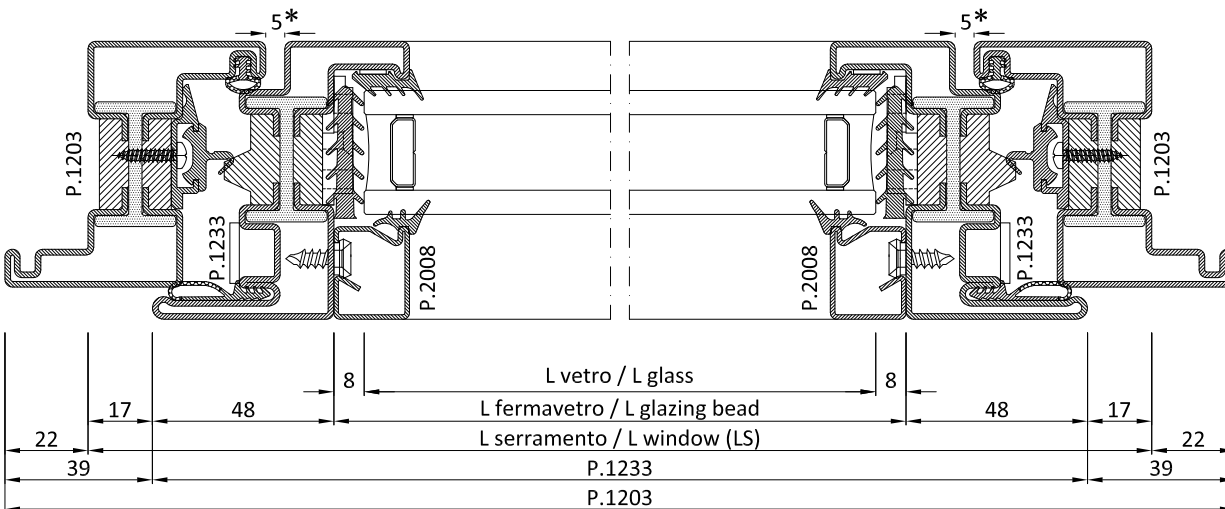

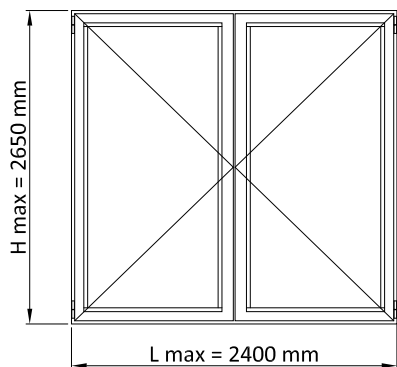

PROFILI		PROFILES				
Cod.	Descrizione	Description	n°	Dim.	Taglio	Cutting
<b>Telaio</b>		<b>Frame</b>				
P.1203	Profilo a "Z" telaio	"Z" profile frame	2	LS+44	45°	45°
P.1203	Profilo a "Z" telaio	"Z" profile frame	2	HS+44	45°	45°
<b>Anta</b>		<b>Leaf</b>				
P.1233	Profilo a "Z" anta	"Z" profile frame	4	(LS-43)/2	45°	45°
P.1233	Profilo a "Z" anta	"Z" profile frame	4	HS-34	45°	45°
P.1202	Profilo a "T" anta	"T" profile frame	1	HS-82.5	90°	90°
P.2027	Profilo battiacqua	Water drip profile	2	(LS-183)/2	90°	90°
<b>Fermavetri</b>		<b>Glazing beads</b>				
P.2008	Fermavetro	Glazing bead profile	4	(LS-235)/2	90°	90°
P.2008	Fermavetro	Glazing bead profile	4	HS-170	90°	90°
<b>Vetri</b>		<b>Glass unit</b>				
-	Vetrocamera	Insulated glass	2	[(LS-267)/2] x HS-146		

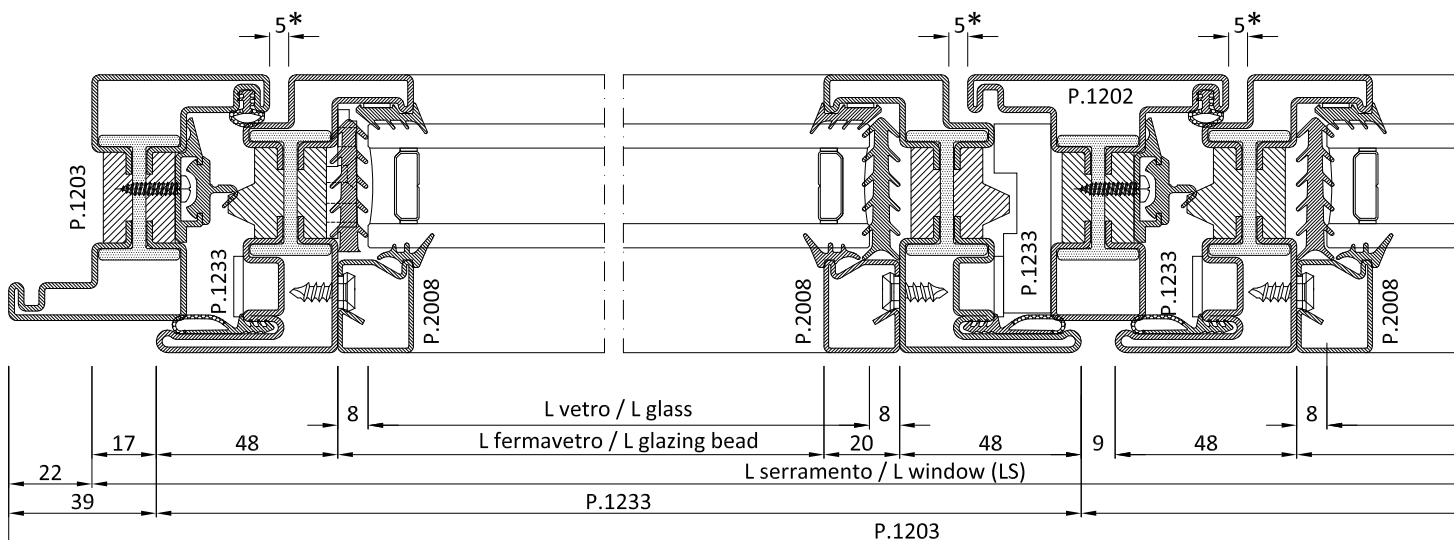



ACCESSORI		HARDWARE	
Cod.	Descrizione	Description	n°
AC12031**	Kit squadrette per P.1729	Corner joint kit for P.1729	4
AC12071**	Kit squadrette per P.1233	Corner joint kit for P.1233	8
AC1215	Kit inversione battuta 2^ anta	2nd leaf reverse closure kit	2
AC1716	Guarnizione d'angolo	Vulcanised corner gasket	4
AC1219	Scarico acqua	Water drip	Var.
AC1237	Cerniera ad avvitare	Screw-on hinge	Var.
AGA271	Meccanismo apertura 1^ anta	1st leaf opening mechanism	1
AGA275	Meccanismo apertura 2^ anta	2nd leaf opening mechanism	1
ACV97..	Maniglia "Vitruvio"	"Vitruvio" handle	1
AC1356	Meccanismo DK	External tilt & turn mechanism	1
AC1020	Supporto spessore vetro	Glass support	12
CV5001(i)	Vite per boccia fermavetro	Screw for glazing bead bushing	Var.
CV5012(i)	Boccola per fermavetro	Bushing for glazing bead	Var.

GUARNIZIONI		GASKETS		
Cod.	Descrizione	Description	n°	Dim.
GE1233TT	Guarnizione esterna di battuta	External rebating gasket	1	2xLS+4xHS
GE1701	Guarnizione giunto aperto	Open joint system gasket	1	2xLS+3xHS
GU1702	Estruso PVC giunto aperto	Open joint system PVC profile	1	2xLS+3xHS
GE1200TT	Guarnizione interna di battuta	Internal rebating gasket	1	2xLS+4xHS
GE1206	Guarnizione esterna vetro	External gasket	1	2xLS+4xHS
GE1007TT	Guarnizione sottovetro	Gasket to put under the glass	1	2xLS+4xHS
GE..	Guarnizione interna vetro	Internal gasket	1	2xLS+4xHS

\* vedi tabella 4.1.5  
see chart 4.1.5

\*\* solo con profili ottone  
only with brass profiles

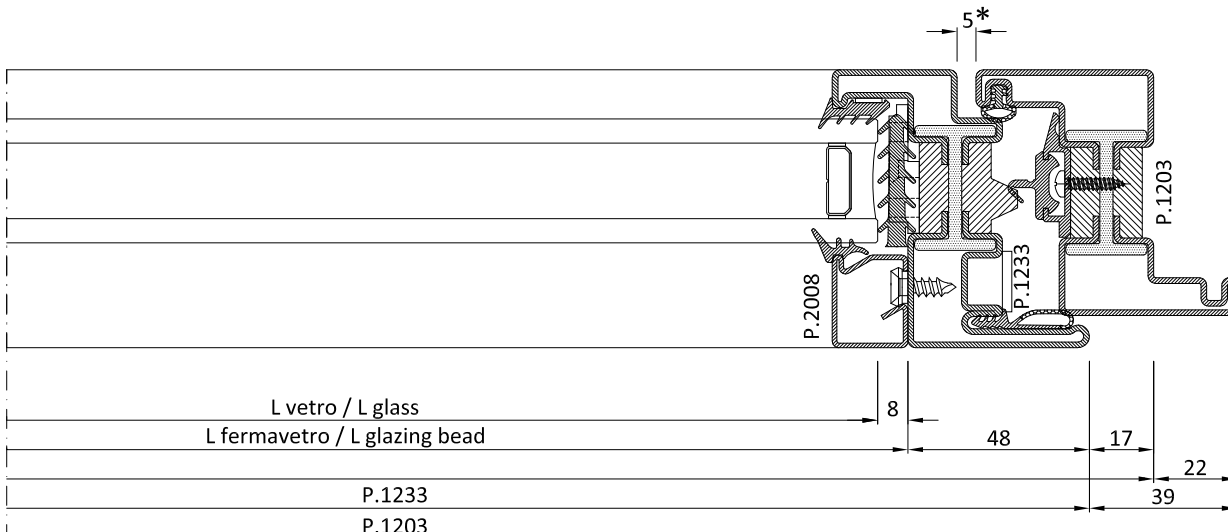
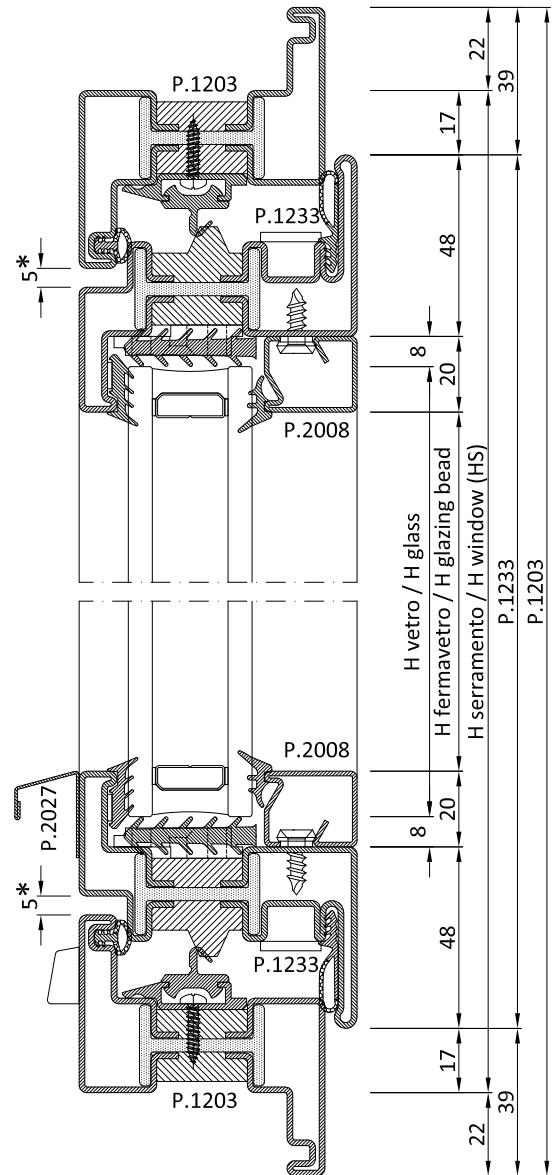

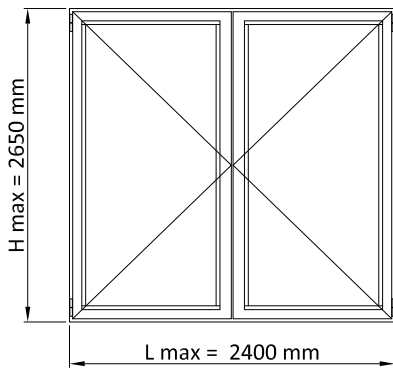

PROFILI		PROFILES				
Cod.	Descrizione	Description	n°	Dim.	Taglio	Cutting
<b>Telaio</b>		<b>Frame</b>				
P.1203	Profilo a "Z" telaio	"Z" profile frame	2	LS+44	45°	45°
P.1203	Profilo a "Z" telaio	"Z" profile frame	2	HS+44	45°	45°
<b>Anta</b>		<b>Leaf</b>				
P.1233	Profilo a "Z" anta	"Z" profile frame	4	(LS-5)/2	45°	45°
P.1233	Profilo a "Z" anta	"Z" profile frame	3	HS-34	45°	45°
P.1724	Profilo a "T" anta	"T" profile frame	1	HS-32	45°	45°
P.2027	Profilo battiacqua	Water drip profile	1	(LS-75)/2	90°	90°
P.2027	Profilo battiacqua	Water drip profile	2	(LS-143)/2	90°	90°
<b>Fermavetri</b>		<b>Glazing beads</b>				
P.2008	Fermavetro	Glazing bead profile	4	(LS-197)/2	90°	90°
P.2008	Fermavetro	Glazing bead profile	4	HS-170	90°	90°
<b>Vetri</b>		<b>Glass unit</b>				
-	Vetrocamera	Insulated glass	2	[(LS-229)/2] x HS-146		

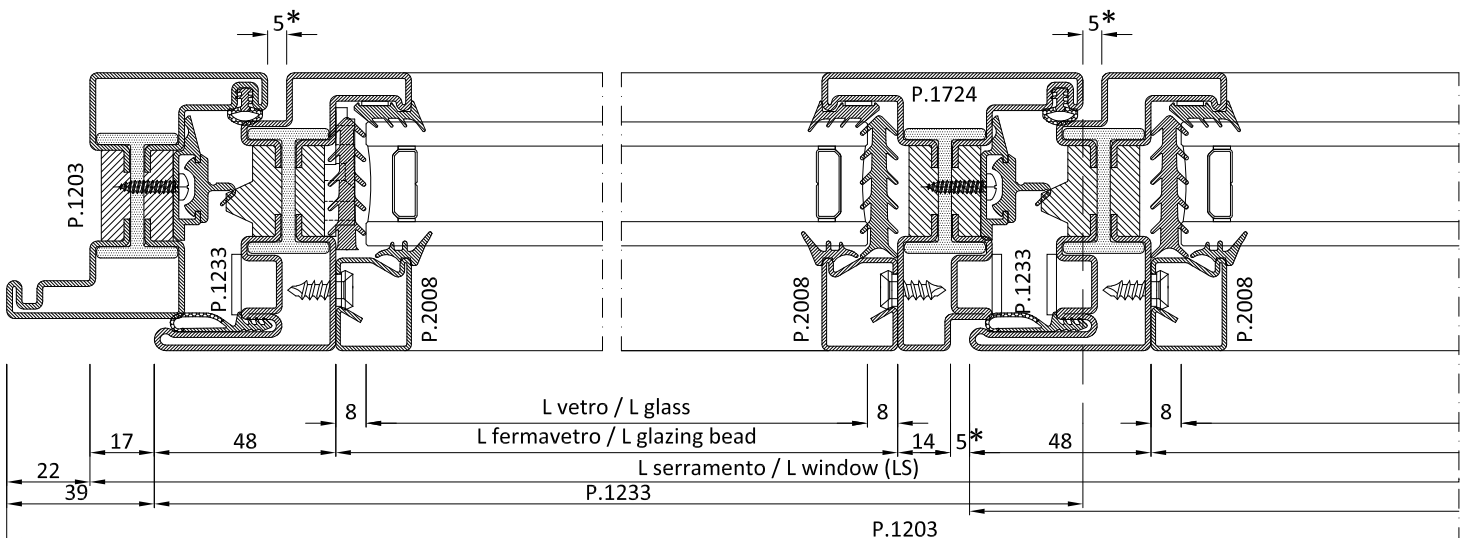

ACCESSORI		HARDWARE	
Cod.	Descrizione	Description	n°
AC12031**	Kit squadrette per P.1729	Corner joint kit for P.1729	4
AC12071**	Kit squadrette per P.1233	Corner joint kit for P.1233	6
AC17081**	Kit squadrette per P.1233-1724	Corner joint kit for P.1233-1724	2
AC1716	Guarnizione d'angolo	Vulcanised corner gasket	4
AC1219	Scarico acqua	Water drip	Var.
AC1714	Kit inversione battuta 2^ anta	2nd leaf reverse closure kit	1
AC1237	Cerniera ad avvitare	Screw-on hinge	Var.
AGA271	Meccanismo apertura 1^ anta	1st leaf opening mechanism	1
AGA775	Meccanismo apertura 2^ anta	2nd leaf opening mechanism	1
ACV97..	Maniglia "Vitruvio"	"Vitruvio" handle	1
AC1356	Meccanismo DK	External tilt & turn mechanism	1
AC1020	Supporto spessore vetro	Glass support	12
CV5001(i)	Vite per boccola fermavetro	Screw for glazing bead bushing	Var.
CV5012(i)	Boccola per fermavetro	Bushing for glazing bead	Var.

GUARNIZIONI		GASKETS		
Cod.	Descrizione	Description	n°	Dim.
GE1233TT	Guarnizione esterna di battuta	External rebating gasket	1	2xLS+3xHS
GE1701	Guarnizione giunto aperto	Open joint system gasket	1	2xLS+3xHS
GE1704	Guarnizione giunto aperto P.1724	Open joint system gasket P.1724	1	1xHS
GU1702	Estruso PVC giunto aperto	Open joint system PVC profile	1	2xLS+3xHS
GE1200TT	Guarnizione interna di battuta	Internal rebating gasket	1	2xLS+3xHS
GE1206	Guarnizione esterna vetro	External gasket	1	2xLS+4xHS
GE1007TT	Guarnizione sottovetro	Gasket to put under the glass	1	2xLS+4xHS
GE..	Guarnizione interna vetro	Internal gasket	1	2xLS+4xHS

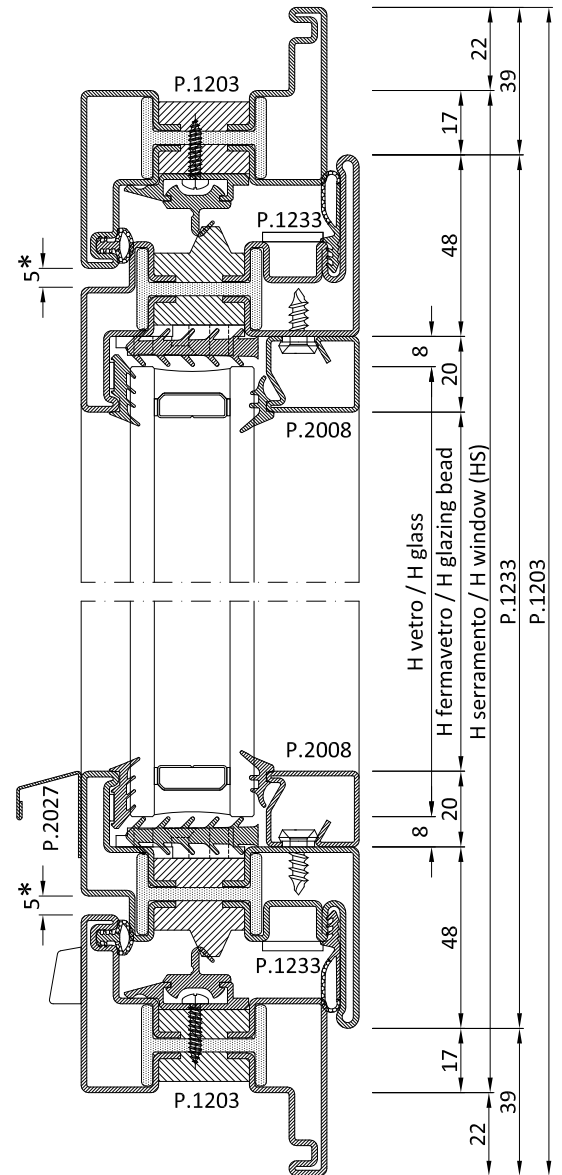

\* vedi tabella 4.1.5  
see chart 4.1.5

\*\* solo con profili ottone  
only with brass profiles

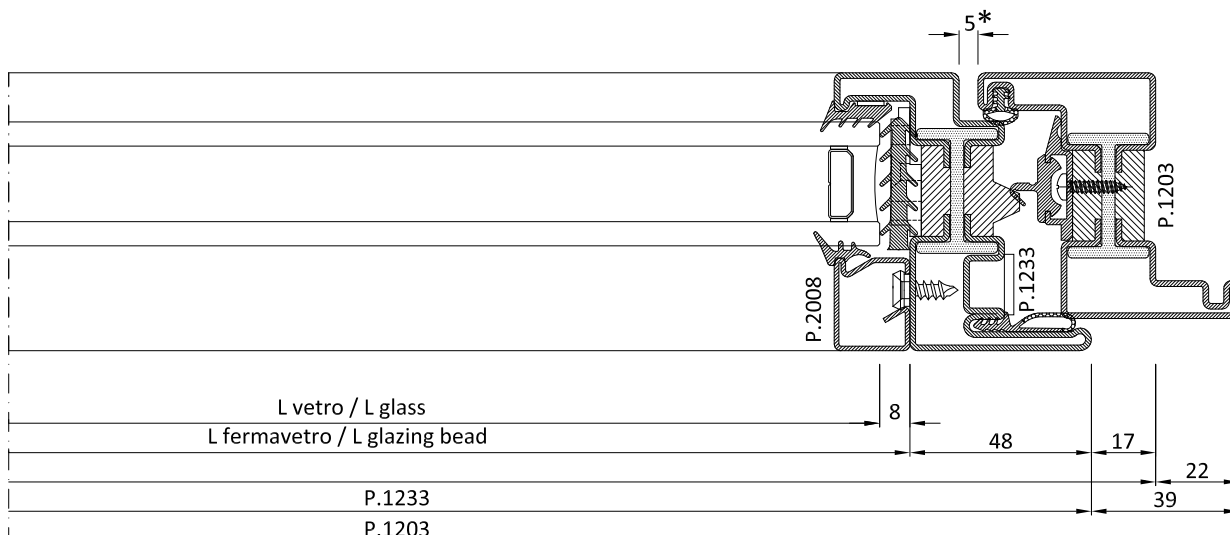

**Distinta di taglio e lista componenti | Cutting list and components list**

Le distinte di taglio e le liste accessori individuate per le diverse tipologie sono state redatte per un serramento tipo.  
E' compito dei tecnici specializzati delle ditte produttrici analizzare criticamente tali indicazioni al fine di verificare la compatibilità del tipo e numero di accessori previsti con il serramento oggetto della commessa reale.

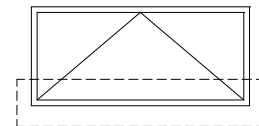

*The cutting and hardware lists, which have been identified for the different typologies, have been produced for a standard window.  
The specialized technicians of the window manufacturers will have to critically analyze such information in order to verify the compatibility of both the type and the number of accessories provided with the window object of the real order.*

**La tabella seguente va attentamente letta prima del taglio dei profili | The following table should be carefully read before the profiles cutting**

In essa è riportata la misura da considerare nella distanza tra telaio anta e telaio fisso nella produzione di finestre in funzione della tipologia, del tipo di cerniera e della larghezza delle ante da produrre.

*It shows the measurement to follow between the leaf and the fixed frame in the production of windows depending on the typology, the hinge type and the width of the leaf to be produced.*

			larghezza anta (cava ferramenta in mm) leaf width (hardware slot in mm)	
			< 480	> 480
Vasistas	AG 1264	aria - gap	6	5
Bottom hung	AG 1274	riscontro - strike	std	std

**NB**  
gli incontri ribassati devono essere installati solamente sul lato cremonese  
*reduced strikes should be installed only on cremone vertical side*

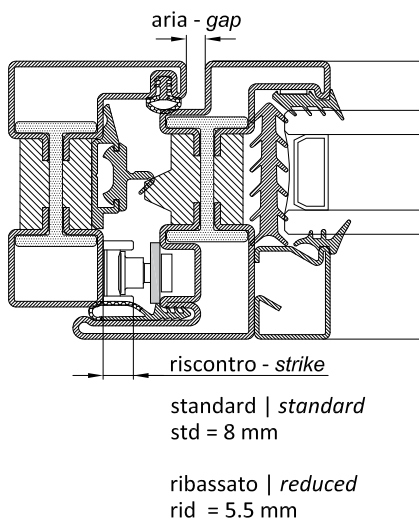

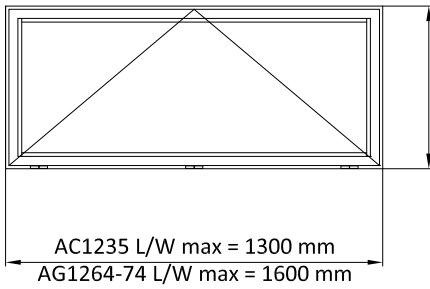

AC1235 H max = 800 mm  
AG1264-74 H max = 1200 mm

PROFILI		PROFILES				
Cod.	Descrizione	Description	n°	Dim.	Taglio Cutting	
<b>Telaio</b>		<b>Frame</b>				
P.1203	Profilo a "Z" telaio	"Z" profile frame	2	LS+44	45°	45°
P.1203	Profilo a "Z" telaio	"Z" profile frame	2	HS+44	45°	45°
<b>Anta</b>		<b>Leaf</b>				
P.1233	Profilo a "Z" anta	"Z" profile frame	2	LS-34	45°	45°
P.1233	Profilo a "Z" anta	"Z" profile frame	2	HS-34	45°	45°
P.2027	Profilo battiacqua	Water drip profile	2	LS-104	90°	90°
<b>Fermavetri</b>		<b>Glazing beads</b>				
P.2008	Fermavetro	Glazing bead profile	2	LS-130	90°	90°
P.2008	Fermavetro	Glazing bead profile	2	HS-170	90°	90°
<b>Vetri</b>		<b>Glass unit</b>				
-	Vetrocamera	Insulated glass	1	LS-146 x HS-146		

ACCESSORI		HARDWARE		
Cod.	Descrizione	Description	n°	Dim.
AC12031**	Kit squadrette per P.1729	Corner joint kit for P.1729	4	
AC12071**	Kit squadrette per P.1233	Corner joint kit for P.1233	4	
AC1716	Guarnizione d'angolo	Vulcanised corner gasket	4	
AC1219	Scarico acqua	Water drip	Var.	
AC../AG..	Cerniere	Hinges	2/3	
AG1264/74..	Meccanismo Vasistas	Bottom hung mechanism	1	
ACV97..	Maniglia "Vitruvio"	"Vitruvio" handle	1	
AC1356	Meccanismo DK	External tilt & turn mechanism	1	
AC1020	Supporto spessore vetro	Glass support	6	
CV5001(i)	Vite per boccia fermavetro	Screw for glazing bead bushing	Var.	
CV5012(i)	Boccola per fermavetro	Bushing for glazing bead	Var.	

GUARNIZIONI		GASKETS		
Cod.	Descrizione	Description	n°	Dim.
GE1233TT	Guarnizione esterna di battuta	External rebating gasket	1	2xLS+2xHS
GE1701	Guarnizione giunto aperto	Open joint system gasket	1	2xLS+2xHS
GU1702	Estruso PVC giunto aperto	Open joint system PVC profile	1	2xLS+2xHS
GE1200TT	Guarnizione interna di battuta	Internal rebating gasket	1	2xLS+2xHS
GE1206	Guarnizione esterna vetro	External gasket	1	2xLS+2xHS
GE1007TT	Guarnizione sottovetro	Gasket to put under the glass	1	2xLS+2xHS
GE..	Guarnizione interna vetro	Internal gasket	1	2xLS+2xHS

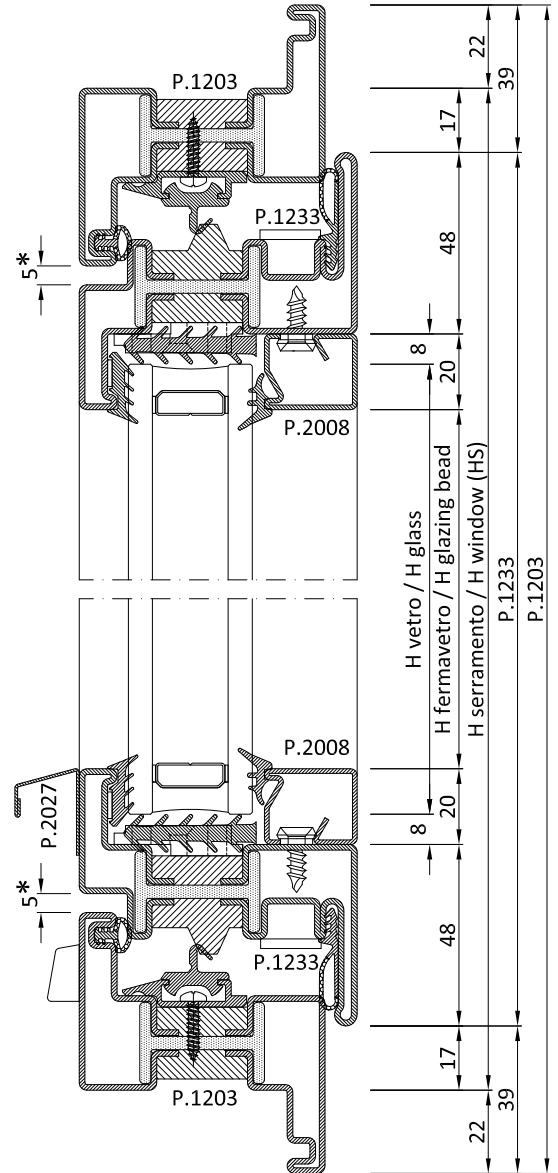

\* vedi tabella 4.1.16  
see chart 4.1.16

\*\* solo con profili ottone  
only with brass profiles

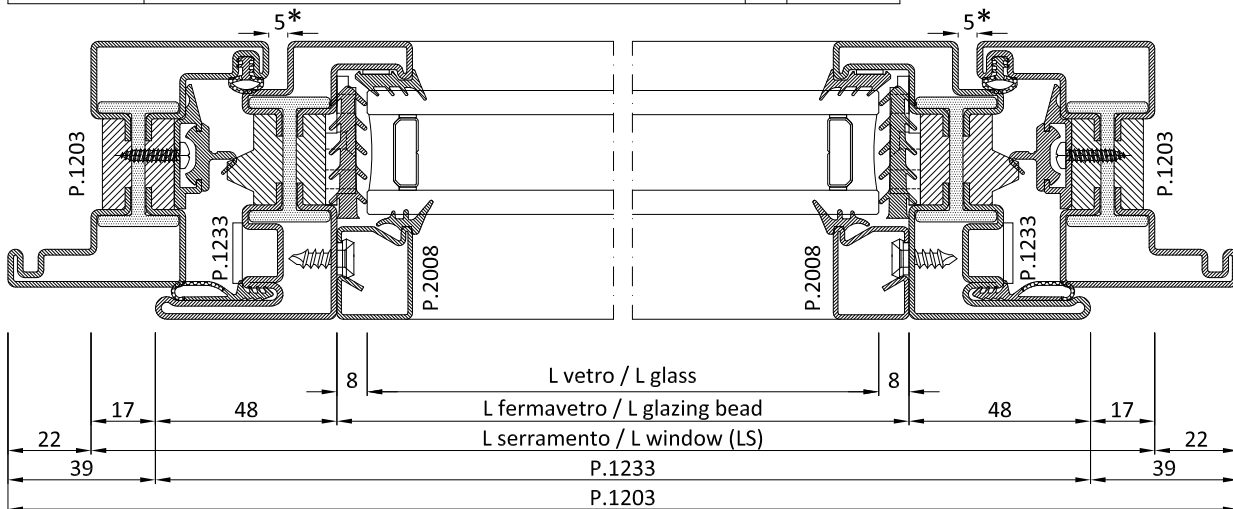

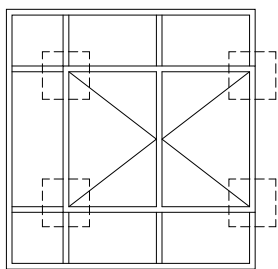
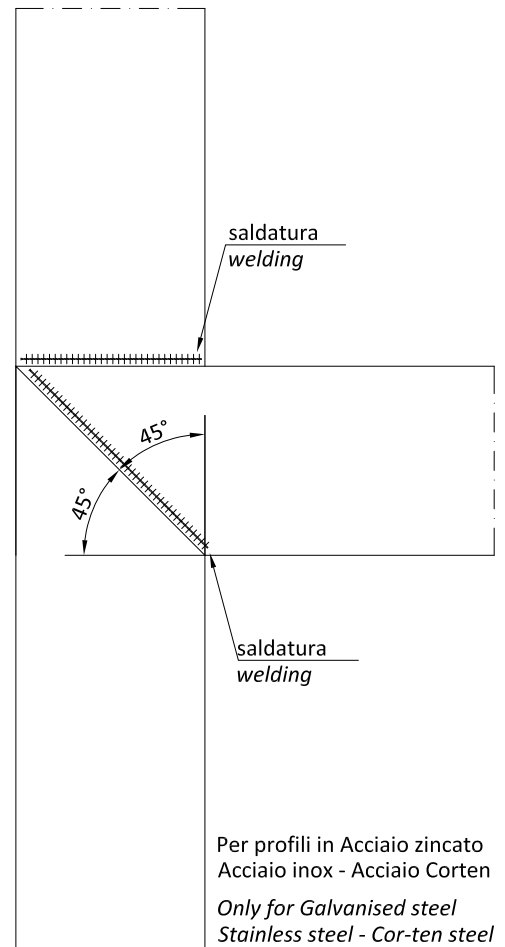
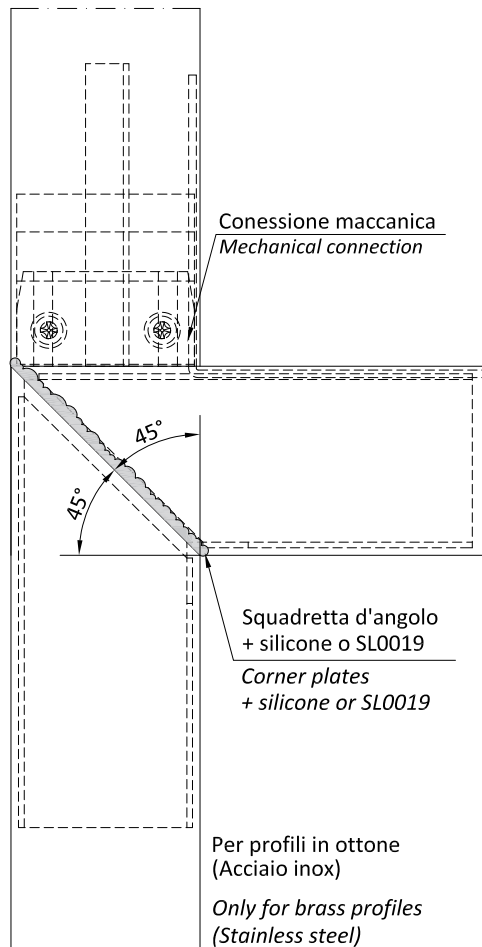
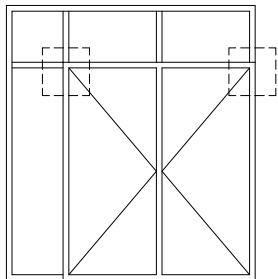
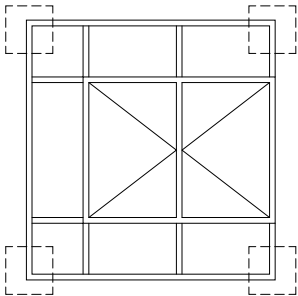
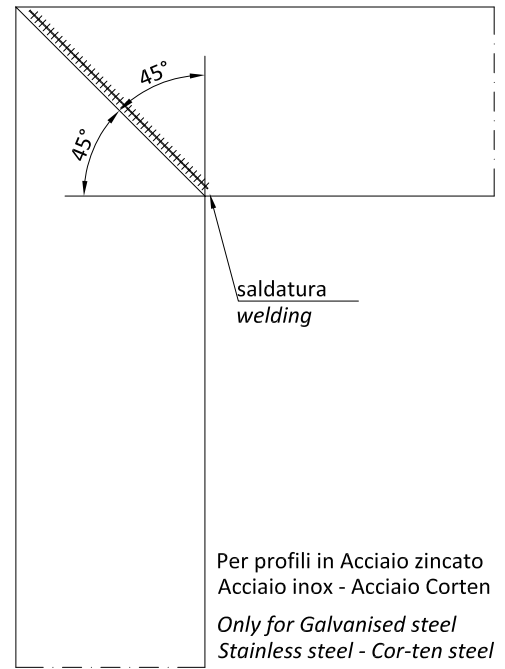
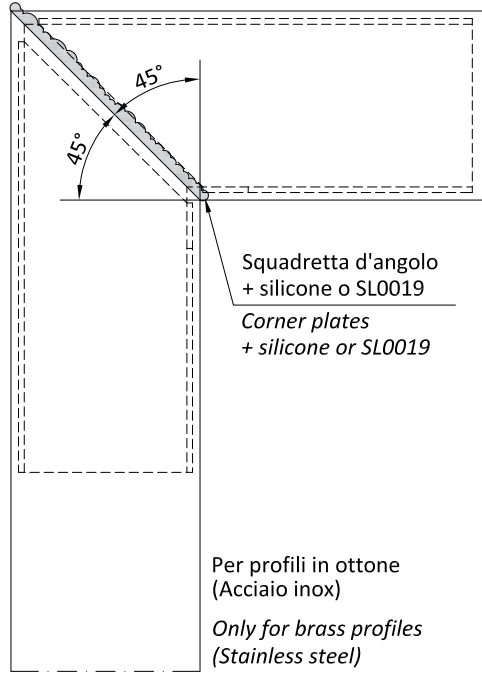
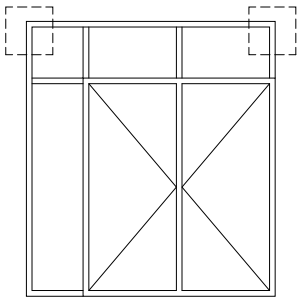

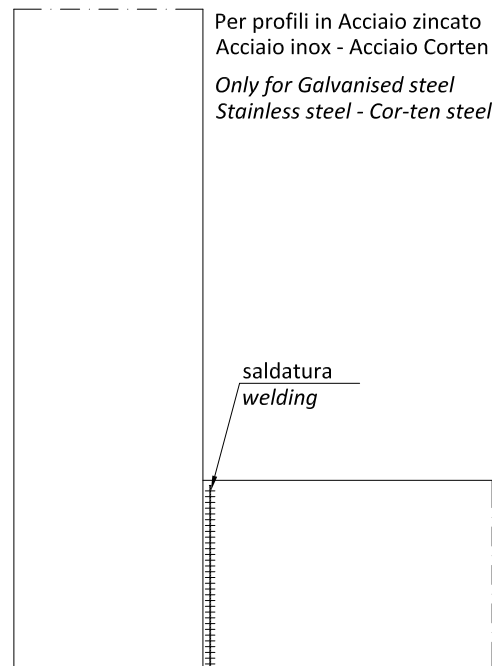
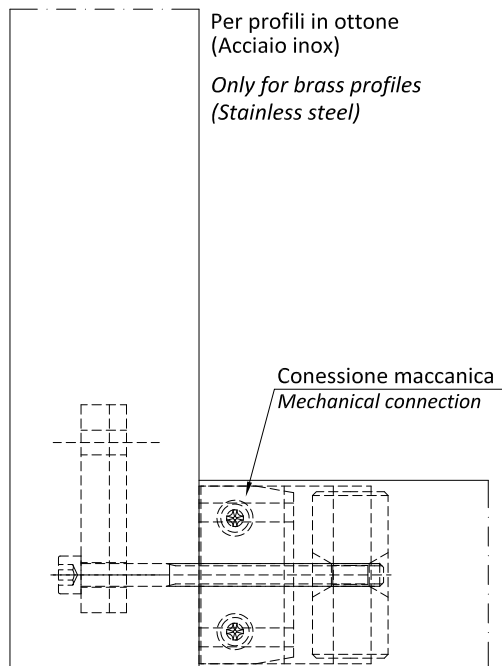
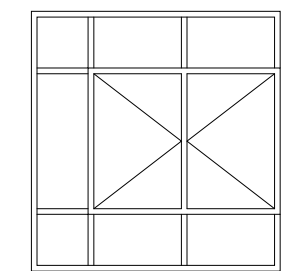
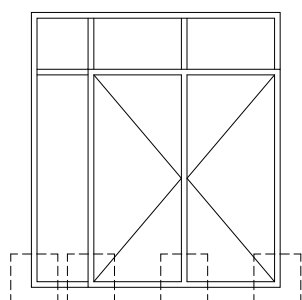
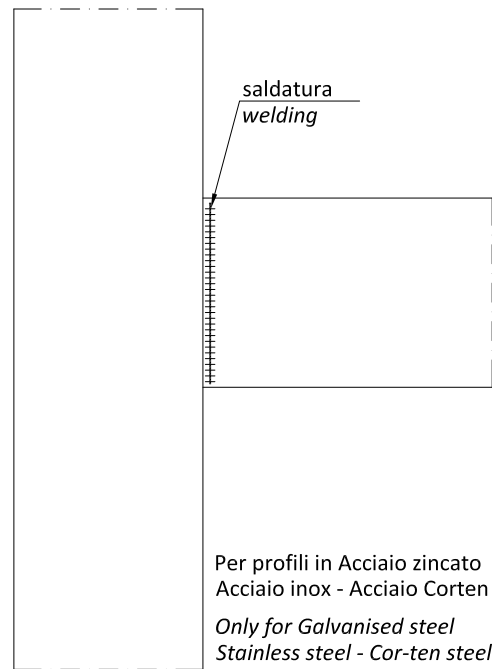
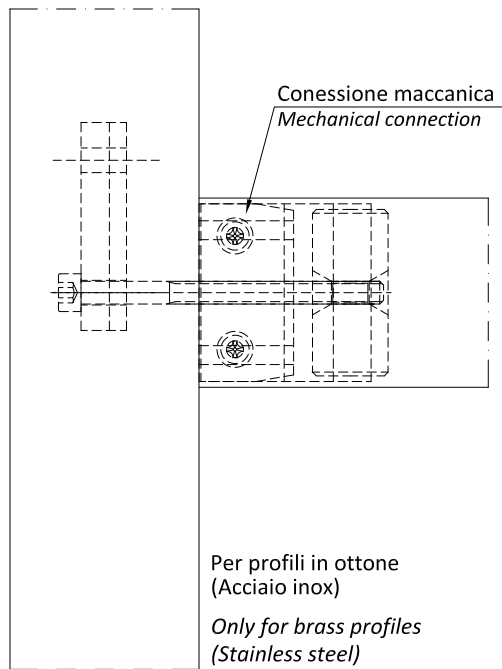
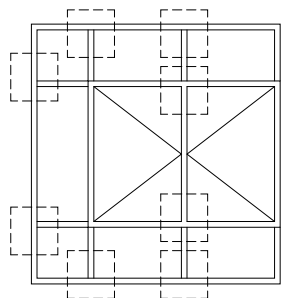
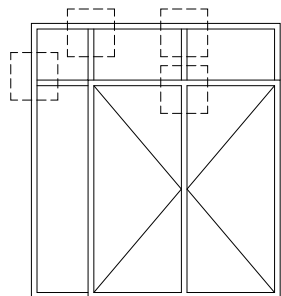

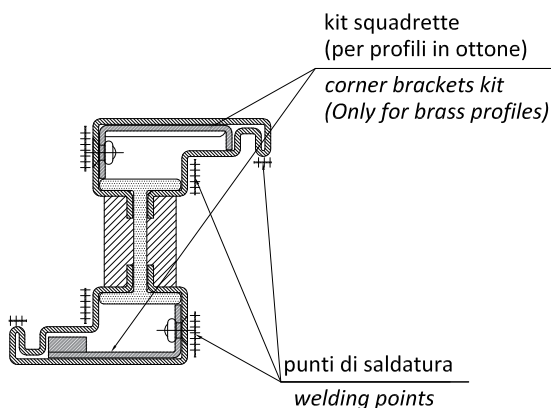
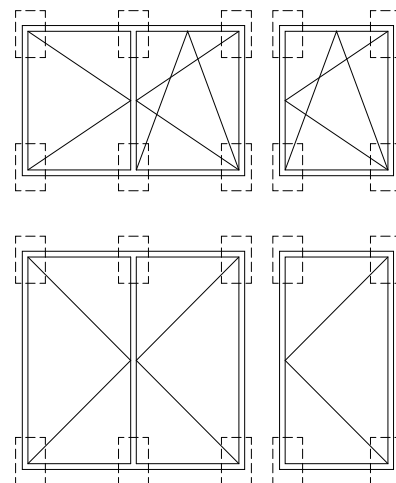
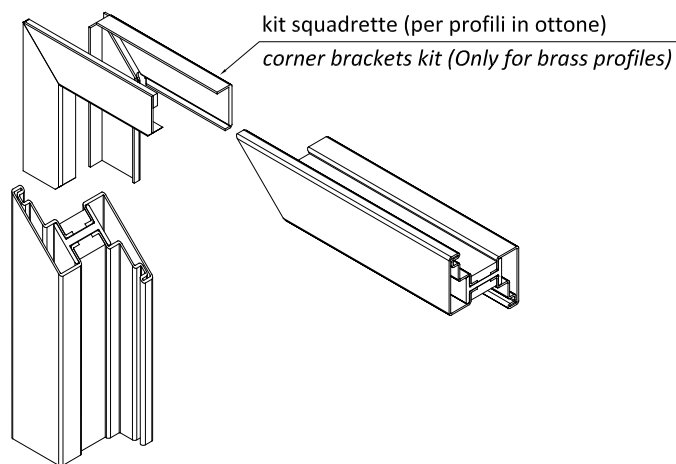

**Ottone**

Utilizzare le squadrette di allineamento, sigillare tutte le superfici di contatto tra i profili che non vanno saldate. Saldare a TIG a punti le zone indicate.

**Brass**

Use corner brackets, seal all surfaces in touch with profiles that are not to be seam-welded. Spot weld (TIG) the marked areas.

**Acciaio zincato - Acciaio Corten - Acciaio inox**

Saldare in continuo le superfici di contatto.

**Galvanised steel - Cor-ten steel - Stainless steel**

Seam-weld all contact surfaces.

Profilo	Profile	Kit squadrette	Corner brackets set
Codice	Code	Codice	Code
P.1001-P.1001		AC 1001I	
P.1002-P.1002		AC 1002I	
P.1003-P.1003		AC 1003I	
P.1011-P.1011		AC 1004I	
P.1012-P.1012		AC 1005I	
P.1013-P.1013		AC 1006I	telaio / frame
P.1013-P.1013		AC 1007I	anta / leaf
P.1012-P.1013		AC 1008I	
P.1005-P.1005		AC 1009I	
P.1010-P.1010		AC 1013I	
P.1027 P.1012		AC 1024ID	
P.1027-P.1012		AC 1024IS	

Profilo	Profile	Kit squadrette	Corner brackets set
Codice	Code	Codice	Code
P.1201-P.1201		AC 1201I	
P.1202-P.1202		AC 1202I	
P.1203-P.1203		AC 1203I	
P.1233-P.1233		AC 1207I	
P.1205-P.1205		AC 1209I	
P.1724-P.1233		AC 1208I	
P.1220-P.1220		AC 1730I	
P.1211-P.1211		AC 1731I	
P.1212-P.1212		AC 1732I	
P.1213-P.1213		AC 1733I	anta / leaf
P.1213-P.1213		AC 1733IE	telaio / frame
P.1215-P.1215		AC 1735I	



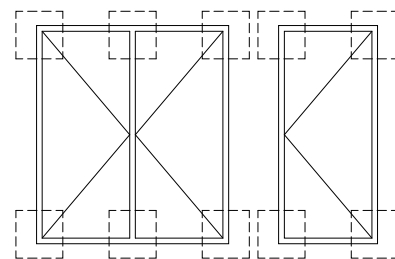
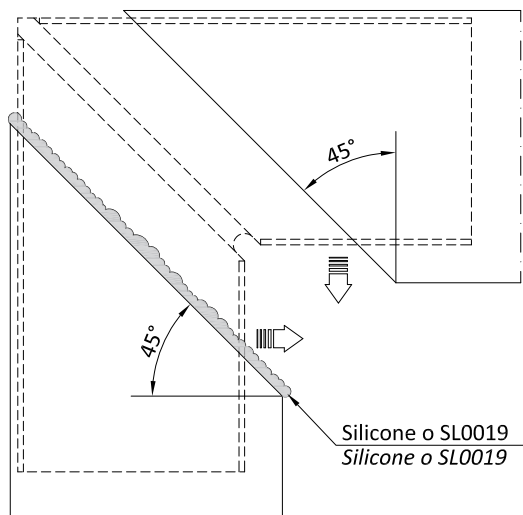

- 1) inserire la squadretta
- 2) siliconare nelle zone indicate
- 3) accostare i profili
- 4) procedere con la saldatura (vedasi pagine successive)

- 1) insert the bracket
- 2) seal in the specified areas
- 3) align the profiles
- 4) weld (see following pages)

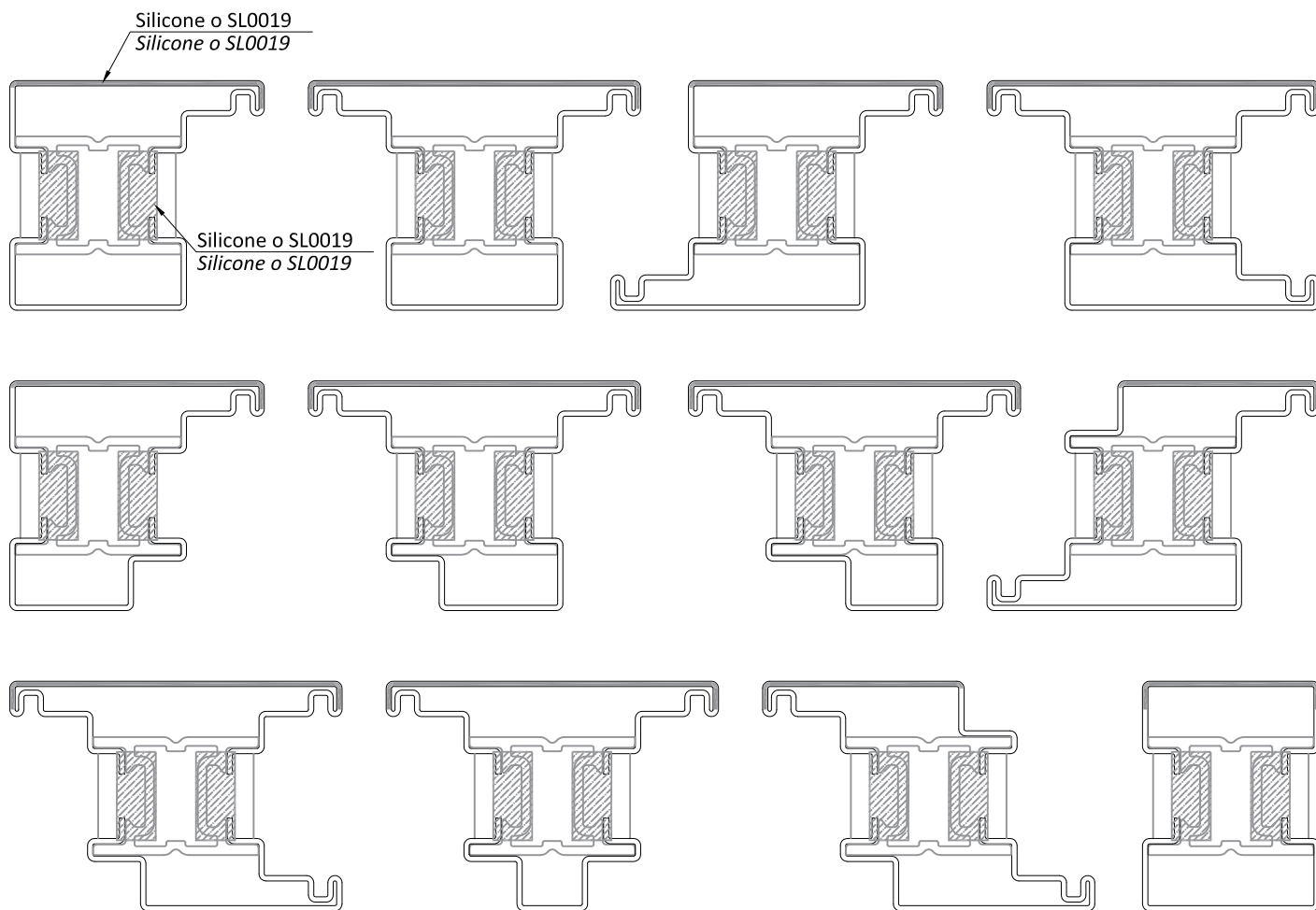

Sigillare con silicone o sigillante a freddo SL0019 nelle zone evidenziate (sempre lato esterno profilo)  
 Seal with silicone or cold-working sealant SL0019 in the areas marked (always on the outer side of the profile)

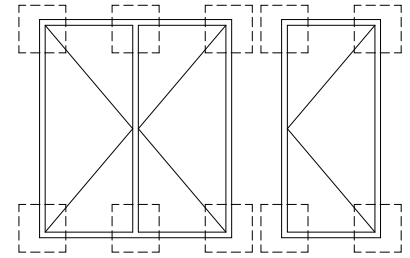
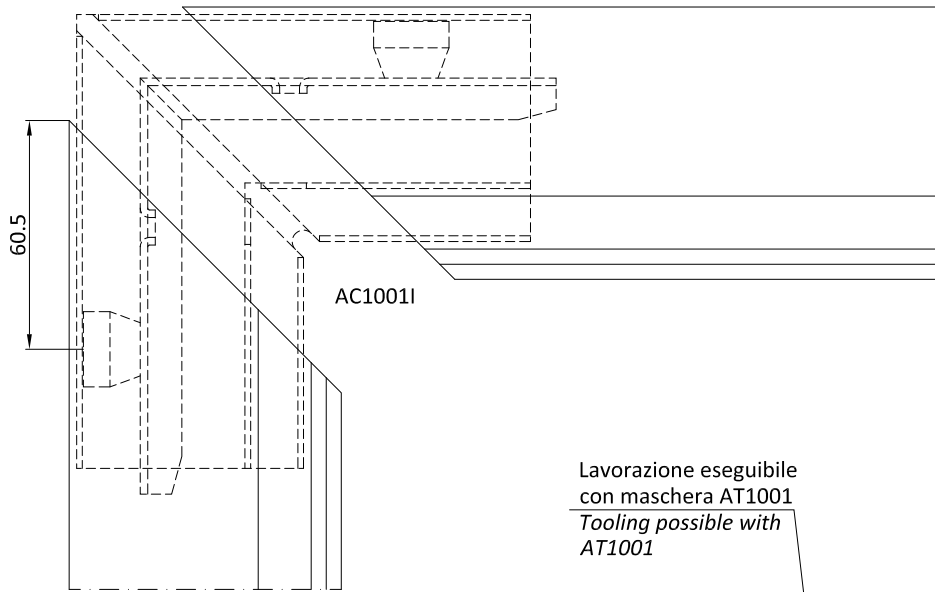

Saldare a TIG con materiale di riporto nelle zone indicate con +++++

Sigillare tutte le superfici di contatto esterne con silicone o SL0019

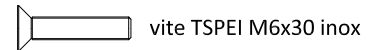

Lavorazione eseguibile con maschera AT1001  
Tooling possible with AT1001

TIG welding with filler material in the areas indicated with +++++

Seal all the external contact surfaces with silicone our SL0019

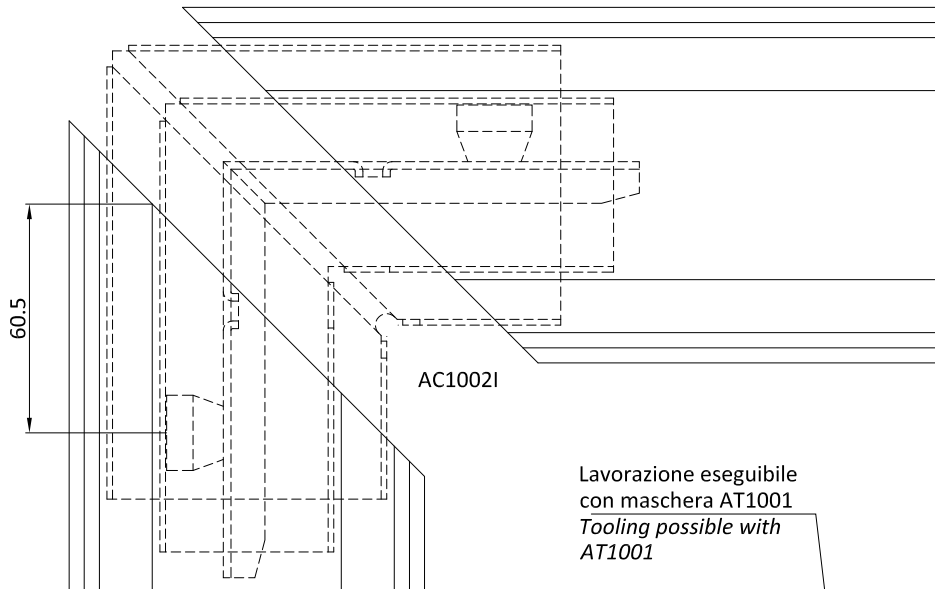
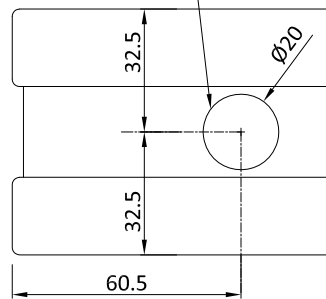
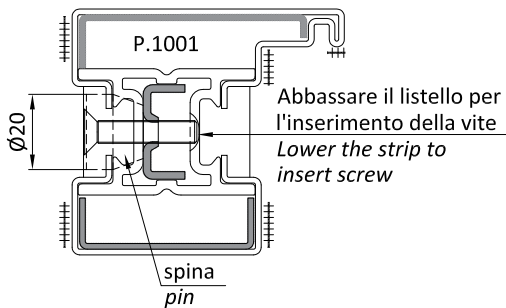

Lavorazione eseguibile con maschera AT1001  
Tooling possible with AT1001

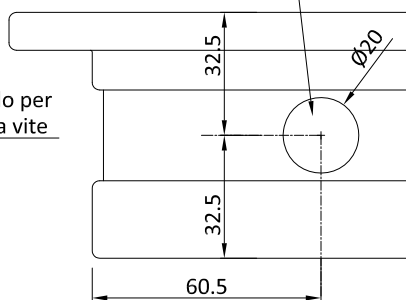
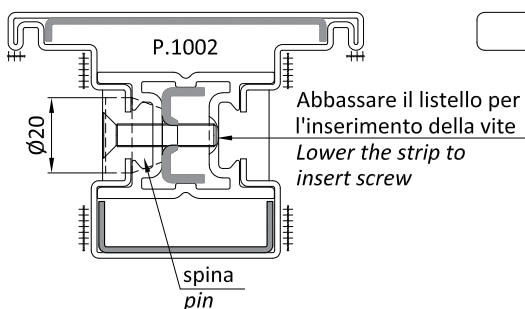

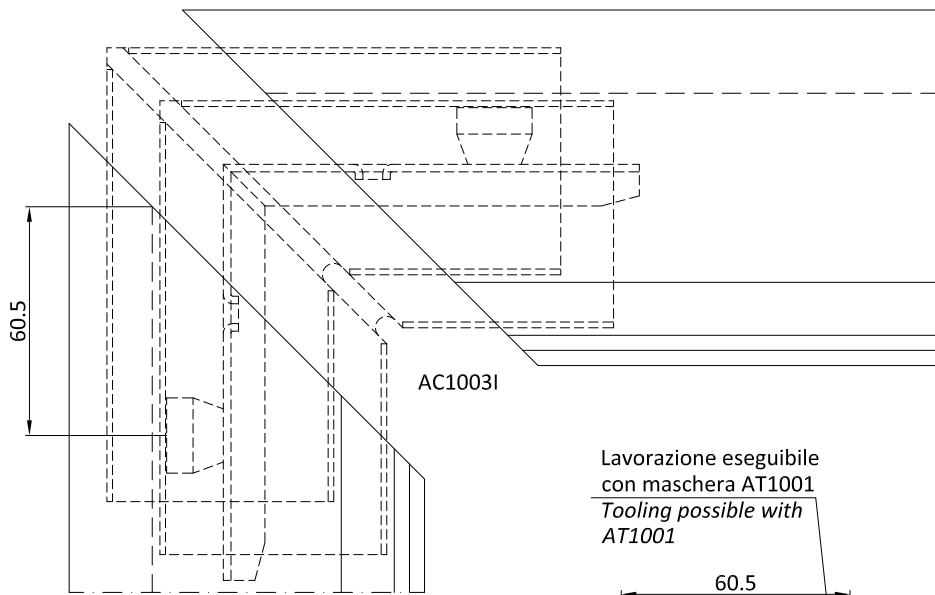

AC1003I

Lavorazione eseguibile  
con maschera AT1001  
Tooling possible with  
AT1001

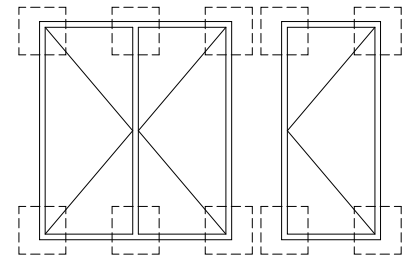
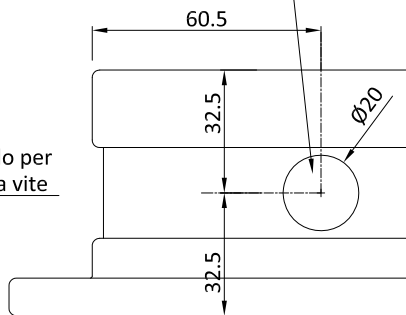
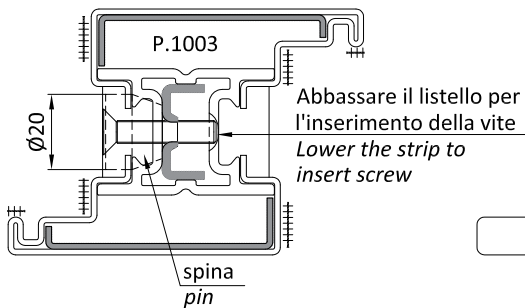

Saldare a TIG con materiale di riporto nelle zone indicate con +++++

Sigillare tutte le superfici di contatto esterne con silicone o SL0019

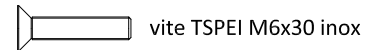

TIG welding with filler material in the areas indicated with +++++

Seal all the external contact surfaces with silicone our SL0019

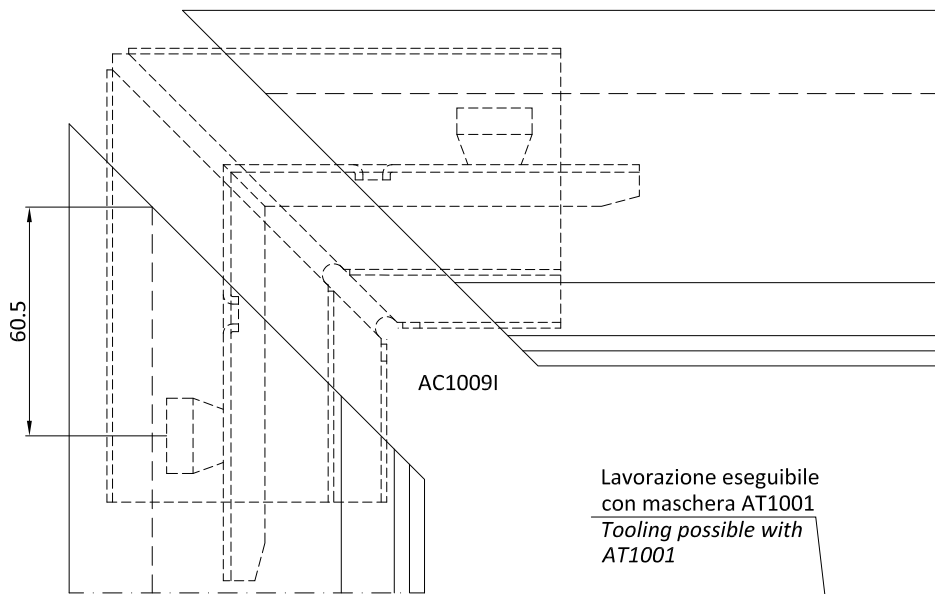

AC1009I

Lavorazione eseguibile  
con maschera AT1001  
Tooling possible with  
AT1001

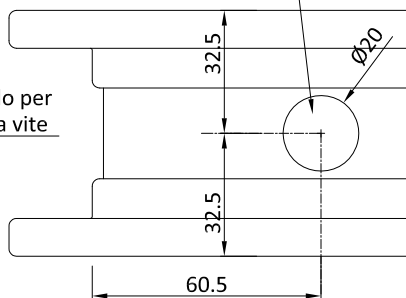
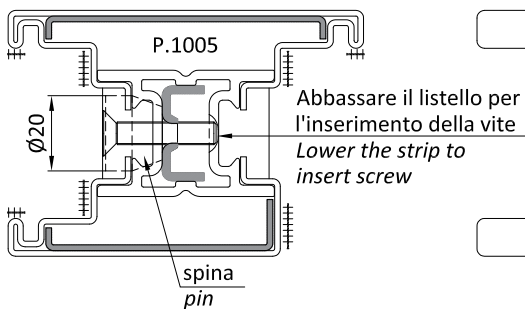

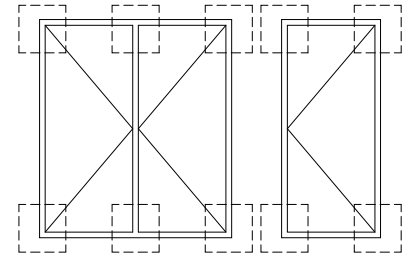
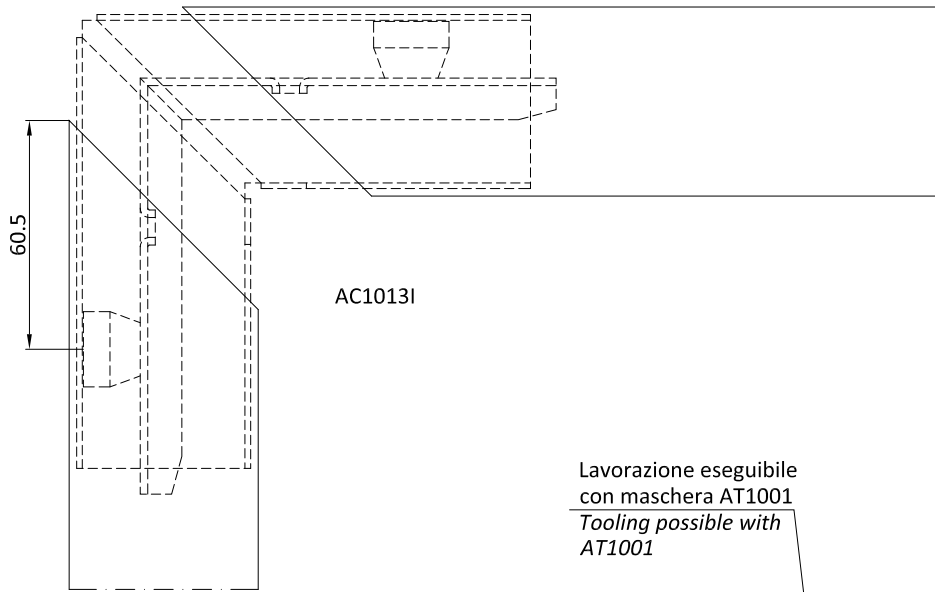

Saldare a TIG con materiale di riporto nelle zone indicate con +++++

Sigillare tutte le superfici di contatto esterne con silicone o SL0019

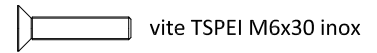

TIG welding with filler material in the areas indicated with +++++

Seal all the external contact surfaces with silicone our SL0019

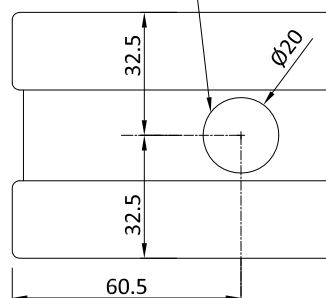
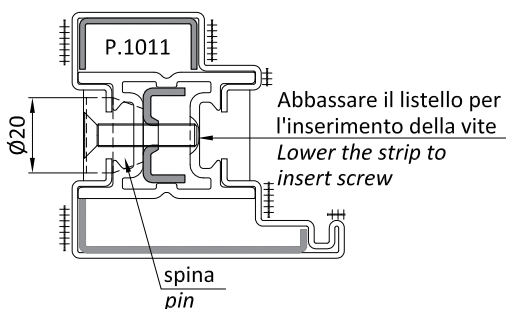
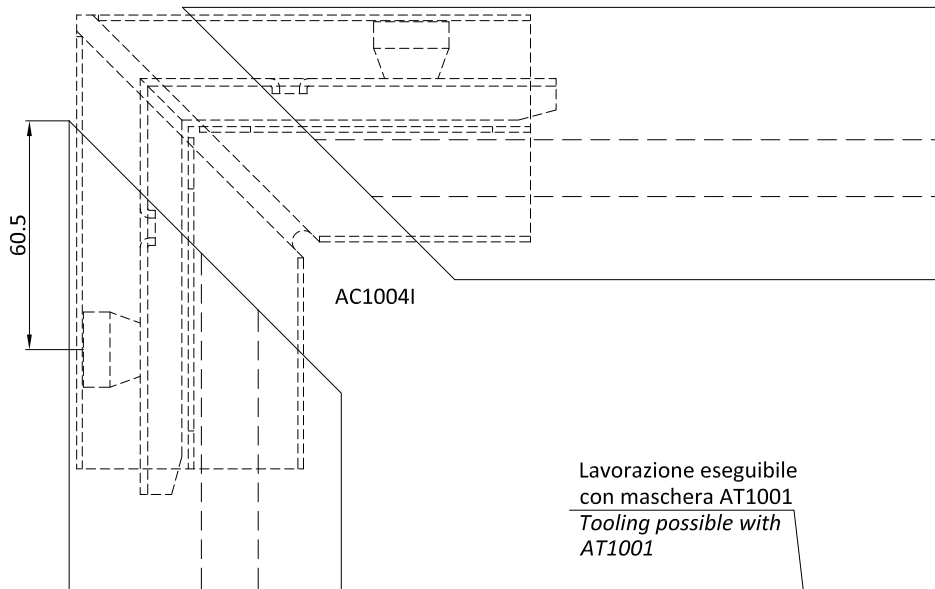
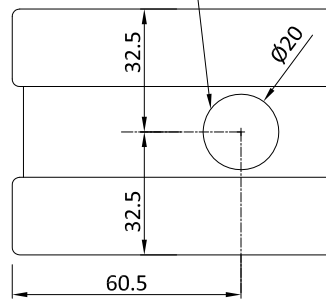
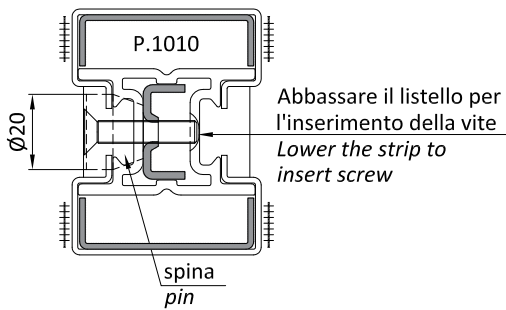

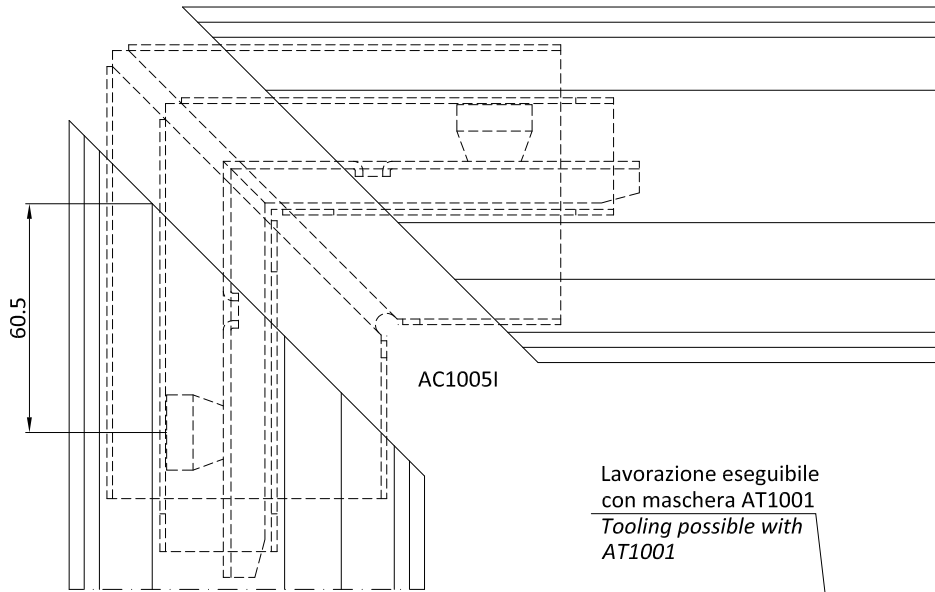

Lavorazione eseguibile  
con maschera AT1001  
Tooling possible with  
AT1001

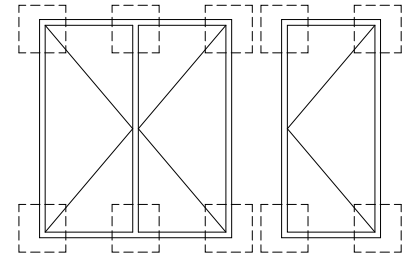

Saldare a TIG con materiale di riporto  
nelle zone indicate con +++++

Sigillare tutte le superfici di contatto  
esterne con silicone o SL0019



TIG welding with filler material in the  
areas indicated with +++++

Seal all the external contact surfaces  
with silicone our SL0019

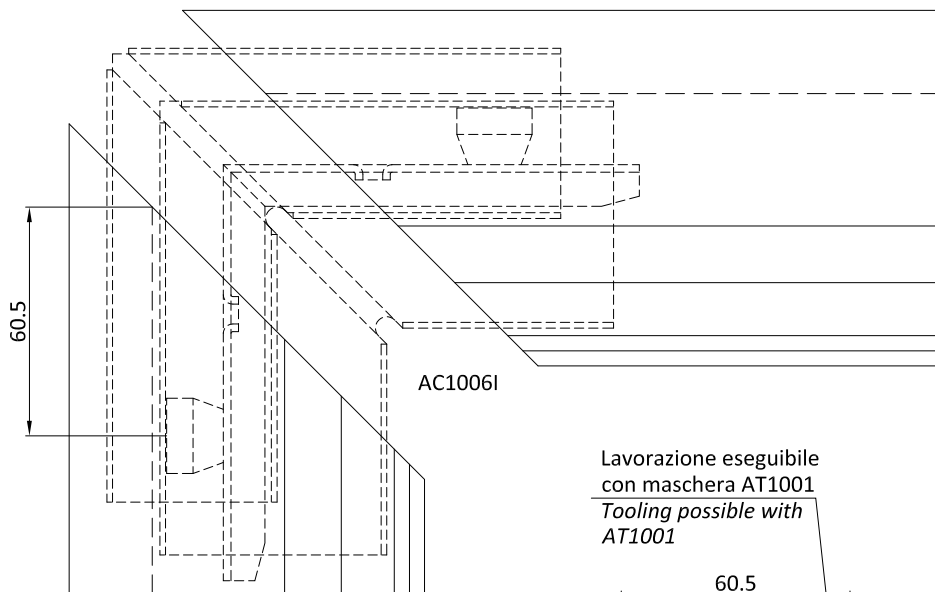
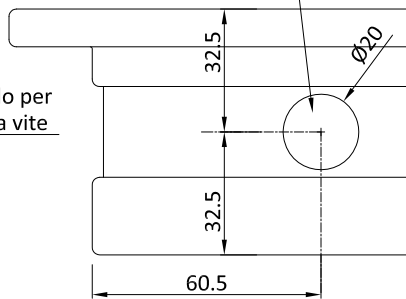
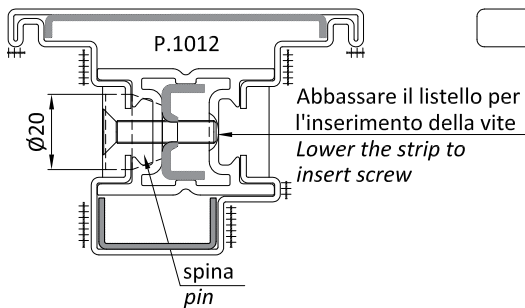

Lavorazione eseguibile  
con maschera AT1001  
Tooling possible with  
AT1001

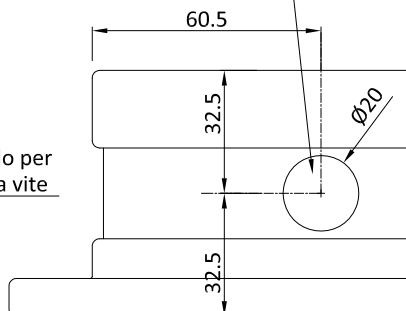
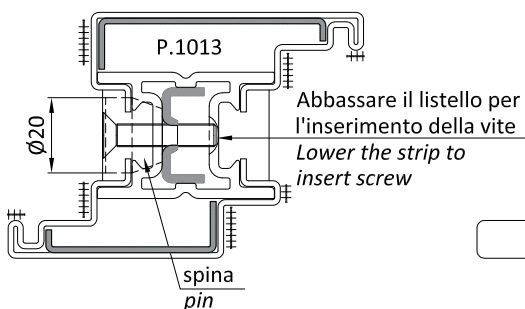

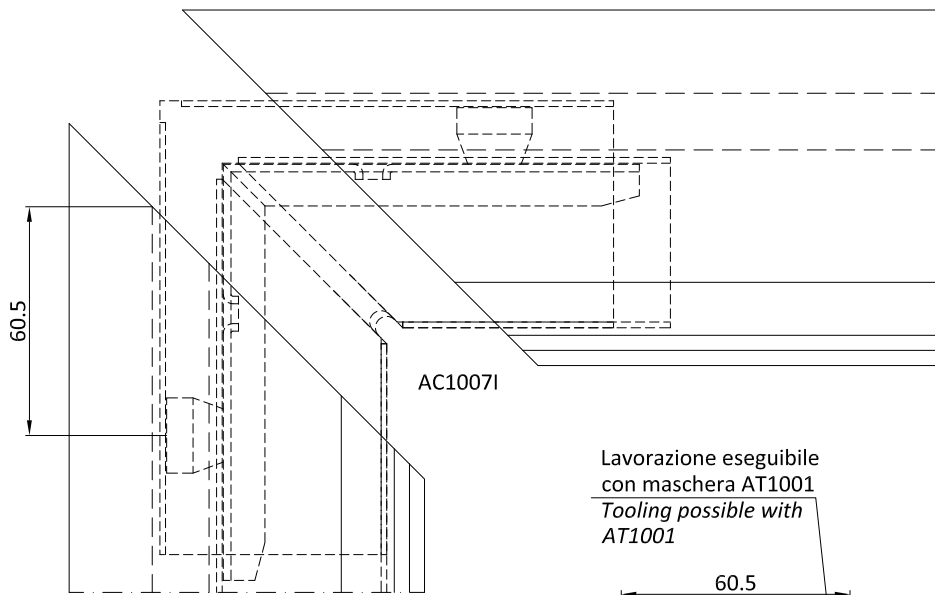

Lavorazione eseguibile  
con maschera AT1001  
Tooling possible with  
AT1001

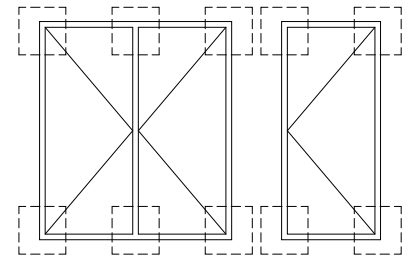
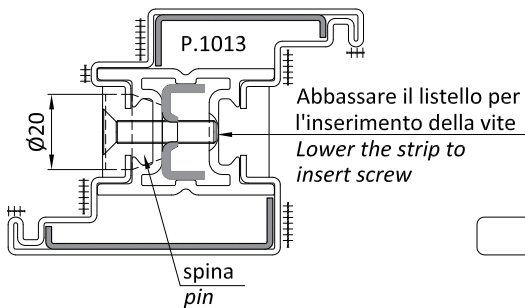
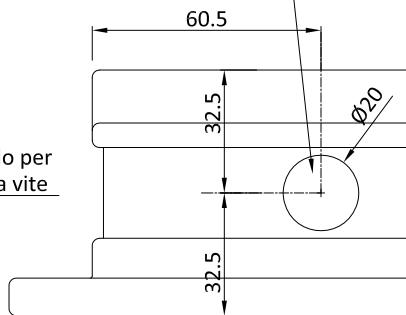

Saldare a TIG con materiale di riporto  
nelle zone indicate con #####

Sigillare tutte le superfici di contatto  
esterne con silicone o SL0019

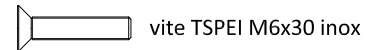

TIG welding with filler material in the  
areas indicated with #####

Seal all the external contact surfaces  
with silicone our SL0019

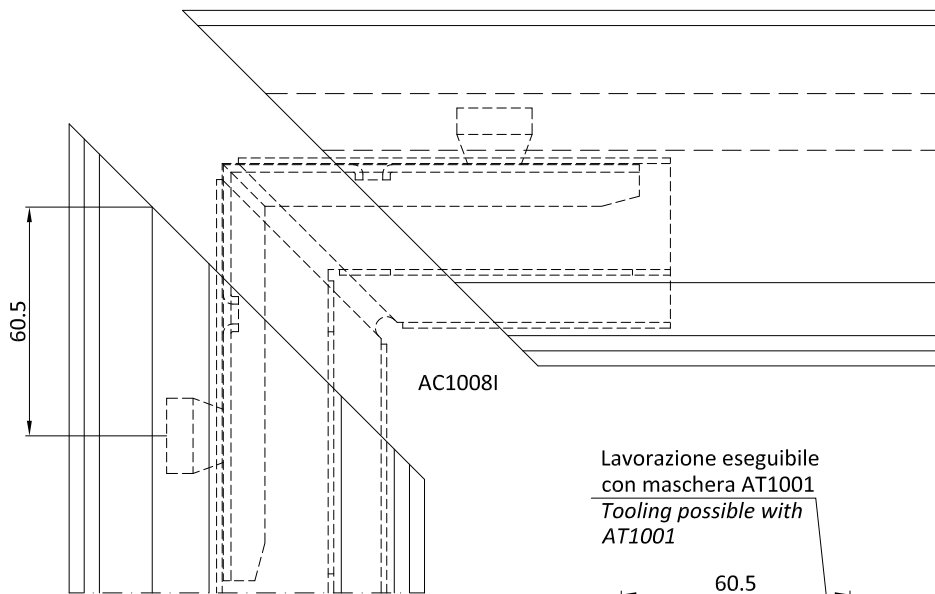

Lavorazione eseguibile  
con maschera AT1001  
Tooling possible with  
AT1001

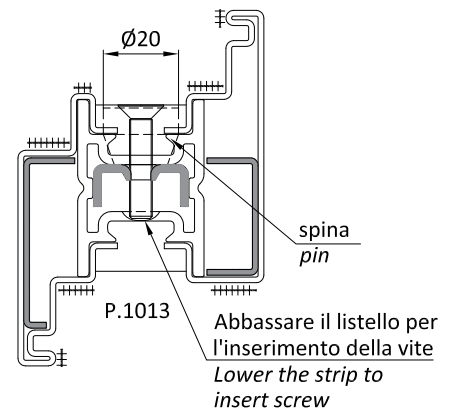
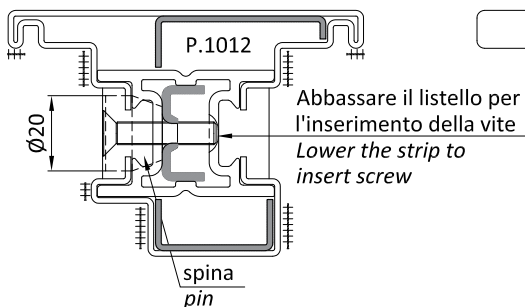
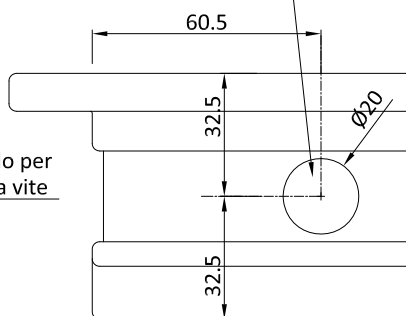

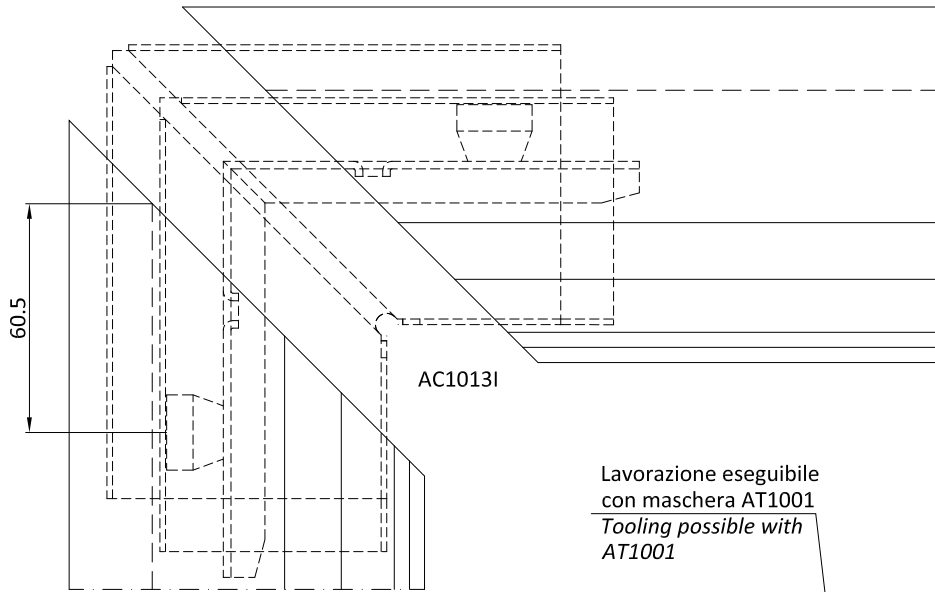

Lavorazione eseguibile  
con maschera AT1001  
Tooling possible with  
AT1001

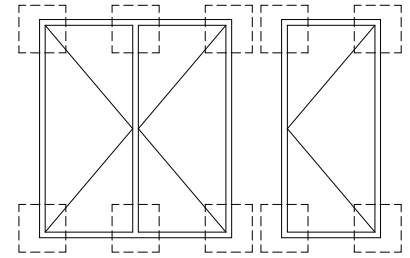

Saldare a TIG con materiale di riporto  
nelle zone indicate con +++++

Sigillare tutte le superfici di contatto  
esterne con silicone o SL0019

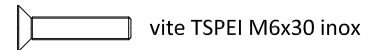

TIG welding with filler material in the  
areas indicated with +++++

Seal all the external contact surfaces  
with silicone our SL0019

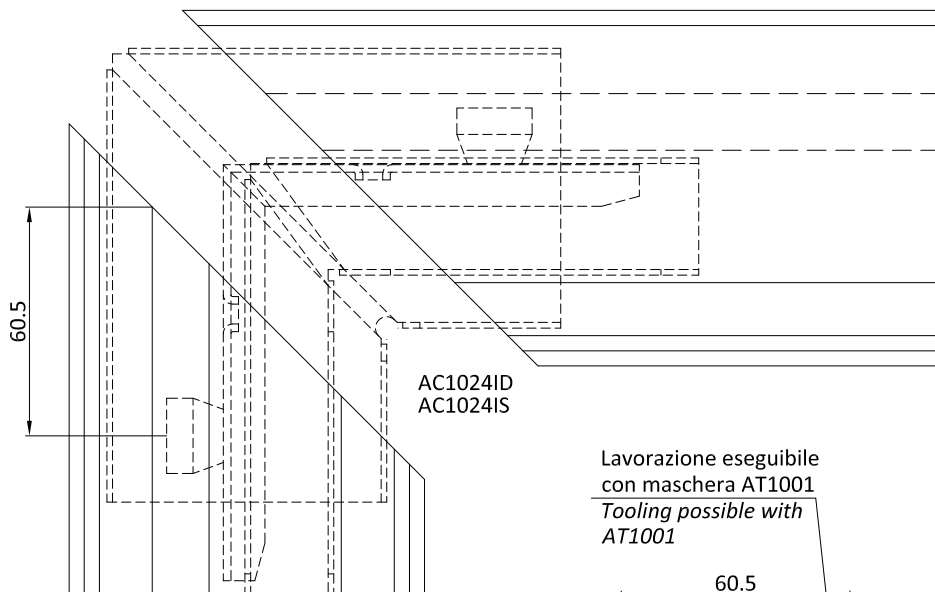
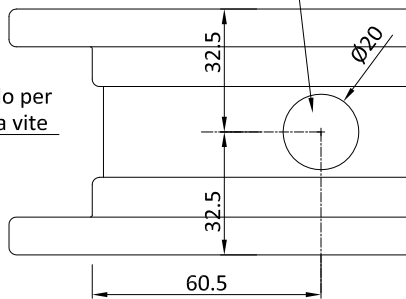
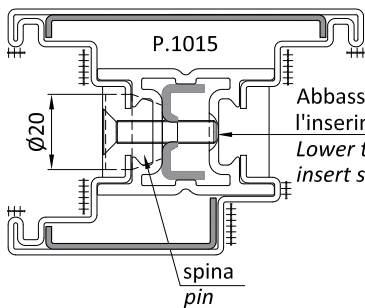

Lavorazione eseguibile  
con maschera AT1001  
Tooling possible with  
AT1001

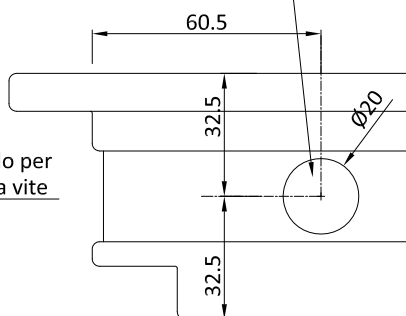
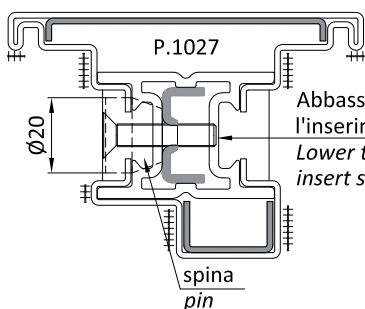
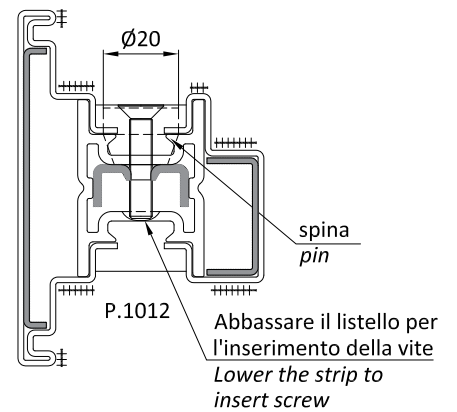

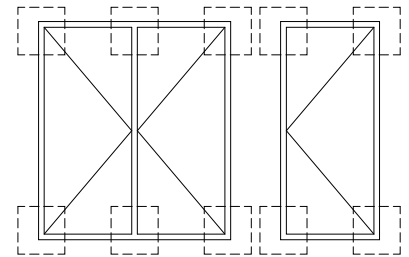
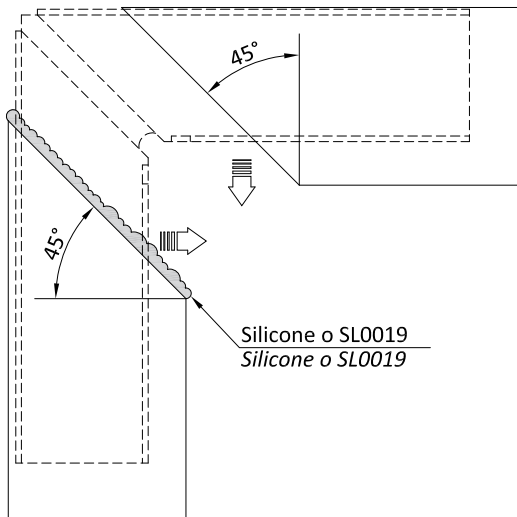

- 1) inserire la squadretta
- 2) siliconare nelle zone indicate
- 3) accostare i profili
- 4) procedere con la saldatura (vedasi pagine successive)

- 1) insert the bracket
- 2) seal in the specified areas
- 3) align the profiles
- 4) weld (see following pages)

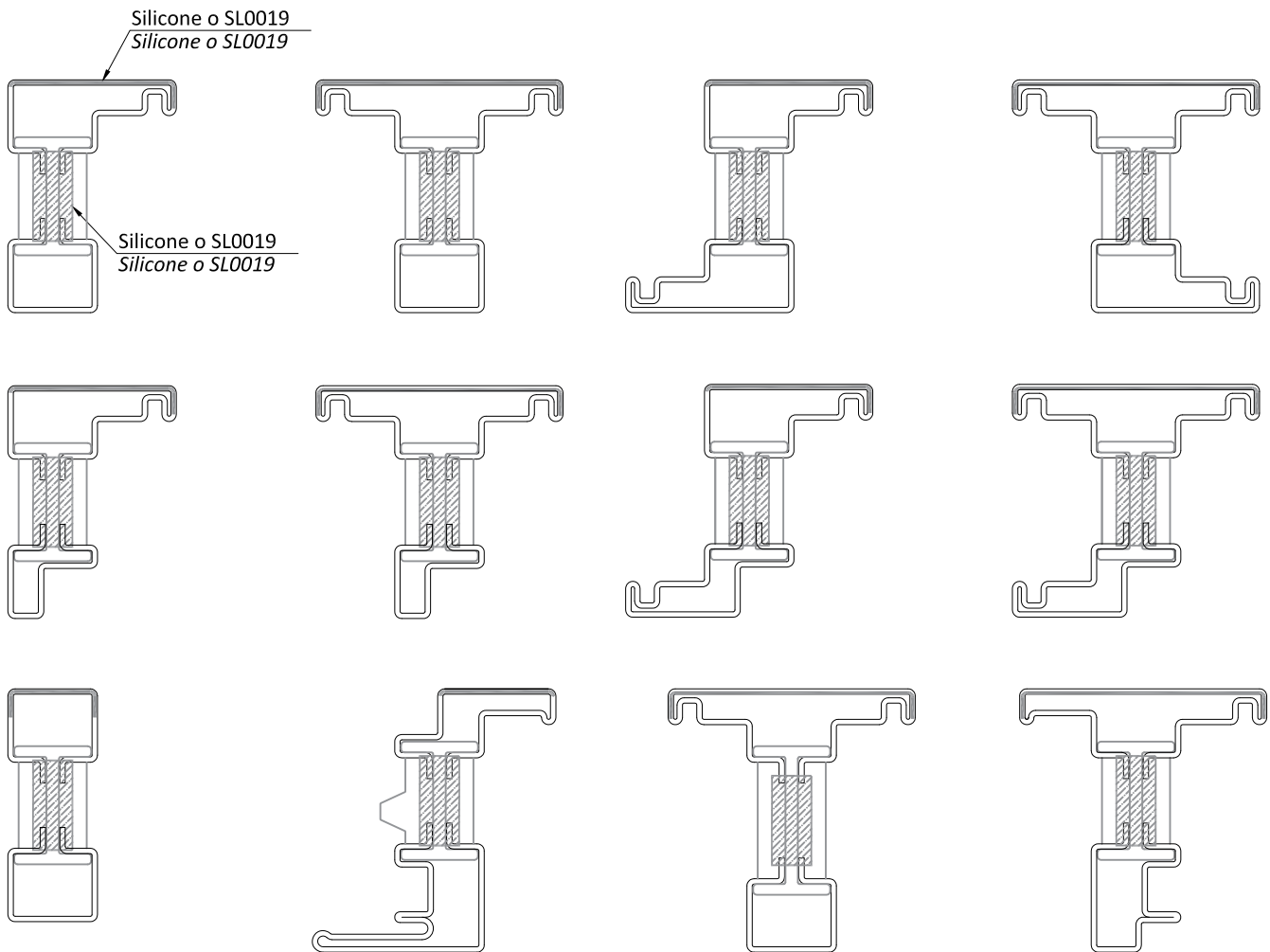

Sigillare con silicone o sigillante a freddo SL0019 nelle zone evidenziate (sempre lato esterno profilo)  
 Seal with silicone or cold-working sealant SL0019 in the areas marked (always on the outer side of the profile)



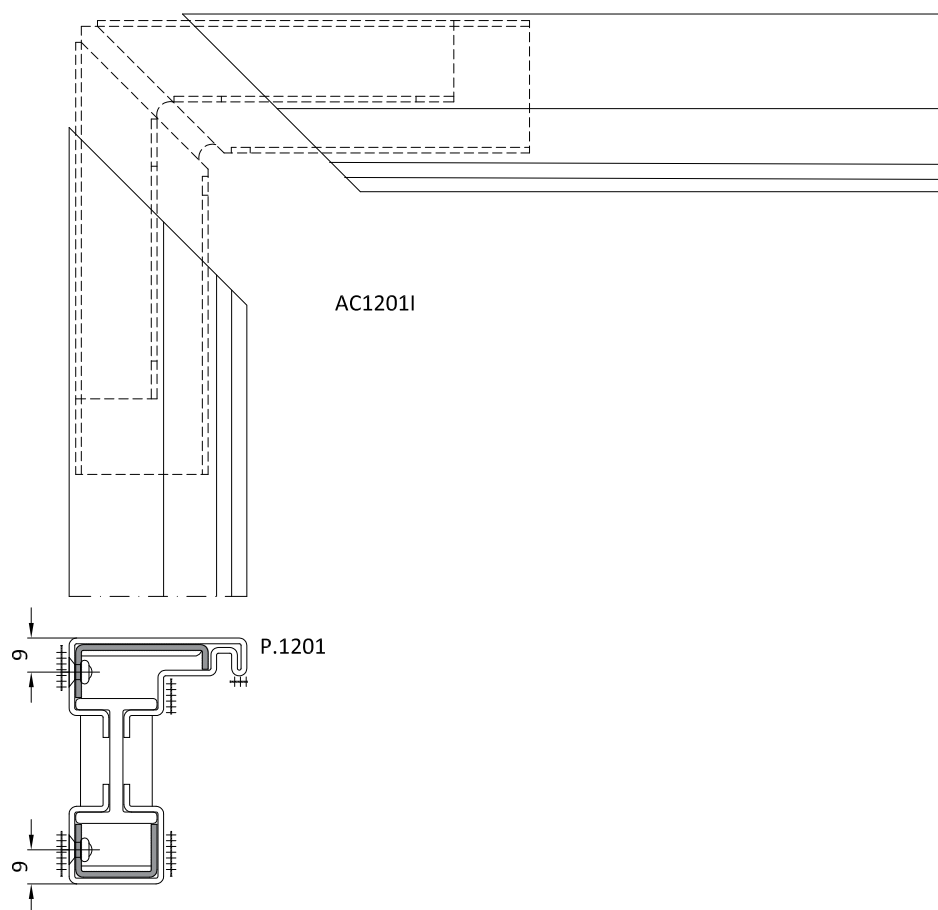

AC1201I

P.1201

P.1202

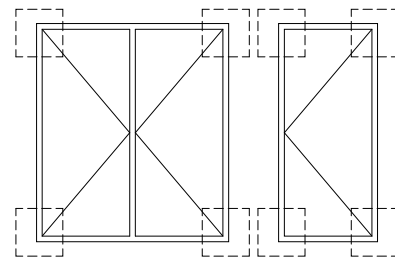

Saldare a TIG con materiale di riporto nelle zone indicate con +++++

Sigillare tutte le superfici di contatto esterne con silicone o SL0019

 Rivetti svasati  $\varnothing 4$

*TIG welding with filler material in the areas indicated with +++++*

*Seal all the external contact surfaces with silicone our SL0019*

 Countersunk rivets  $\varnothing 4$

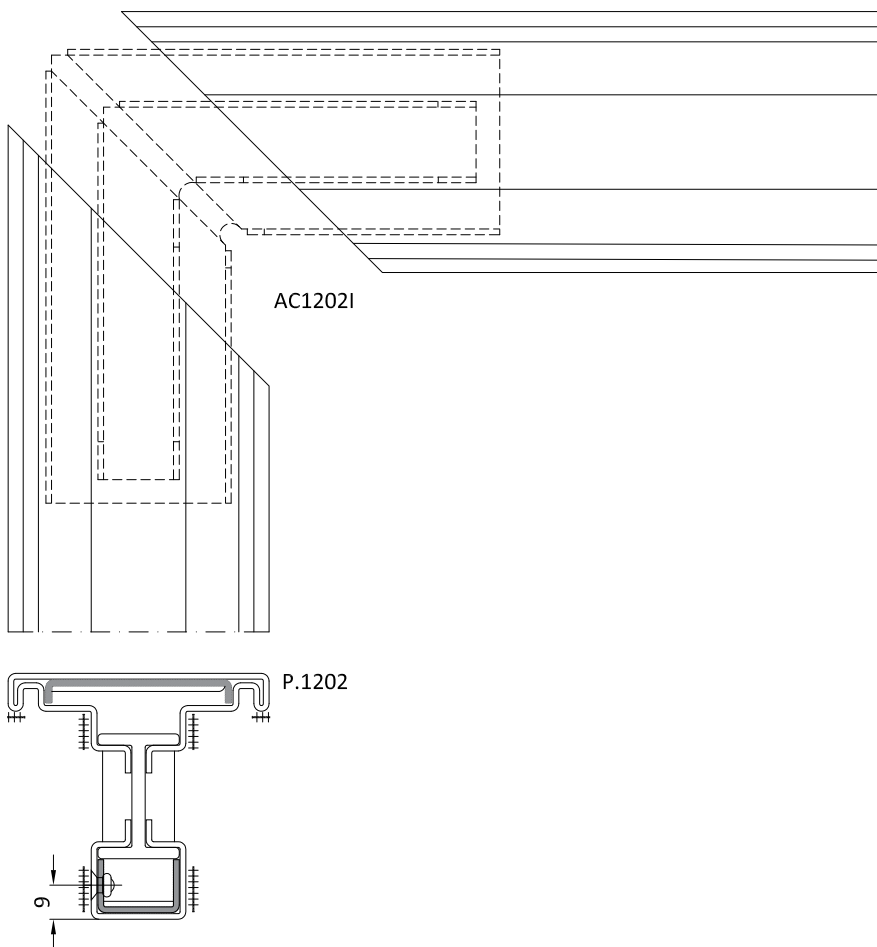

AC1202I

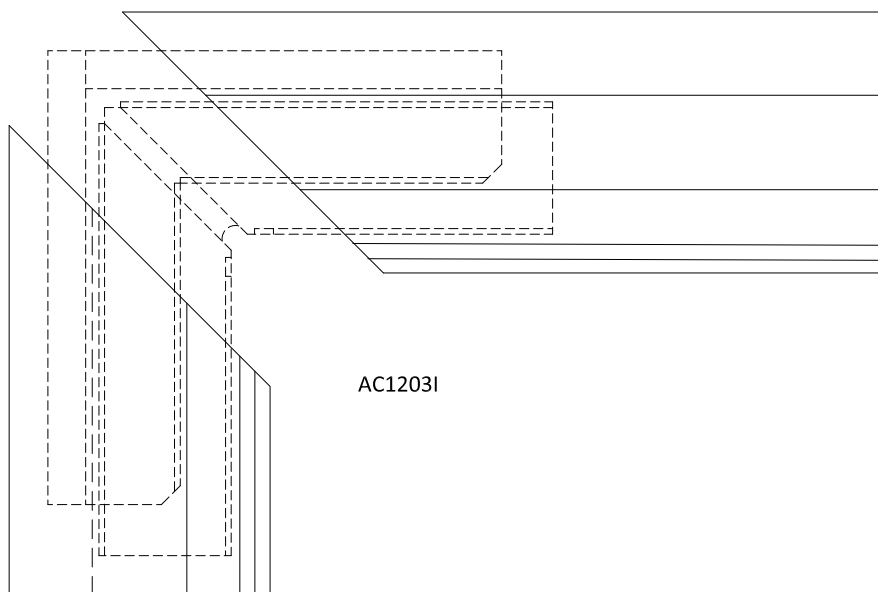

AC1203I

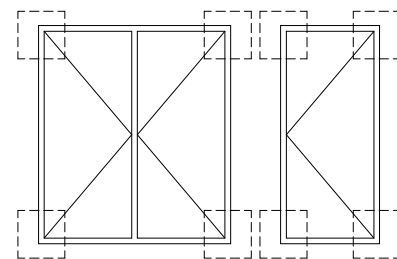
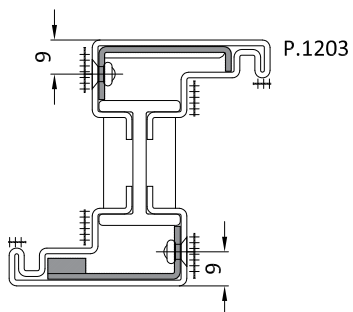

Saldare a TIG con materiale di riporto nelle zone indicate con #####

Sigillare tutte le superfici di contatto esterne con silicone o SL0019

 Rivetti svasati Ø 4

*TIG welding with filler material in the areas indicated with #####*

*Seal all the external contact surfaces with silicone our SL0019*

 Countersunk rivets Ø 4

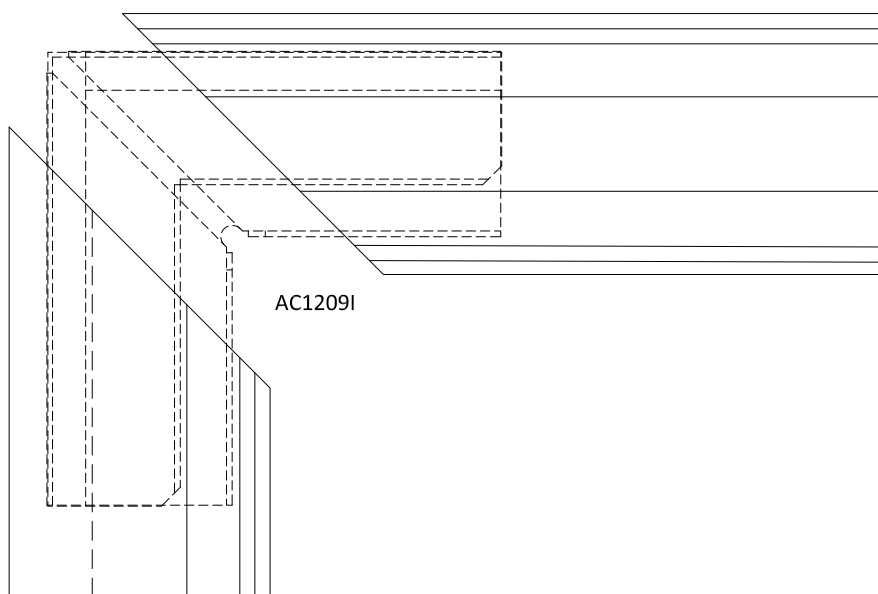

AC1209I

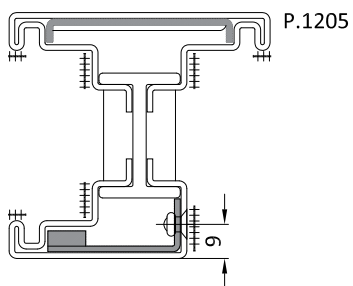

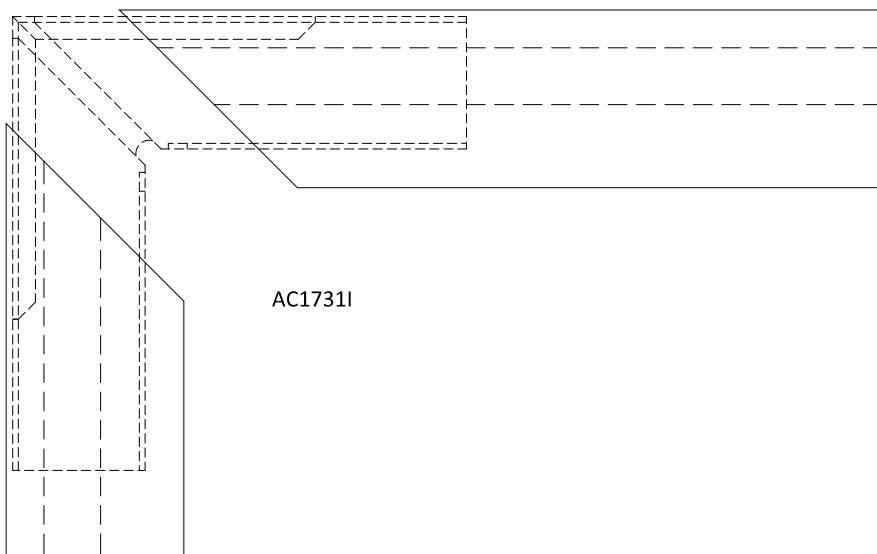

AC1731I

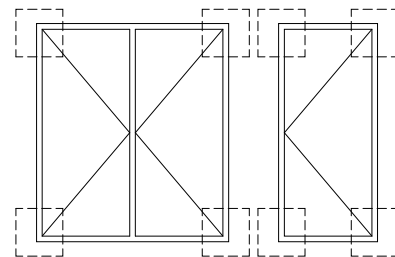

Saldare a TIG con materiale di riporto nelle zone indicate con #####

Sigillare tutte le superfici di contatto esterne con silicone o SL0019

 Rivetti svasati Ø 4

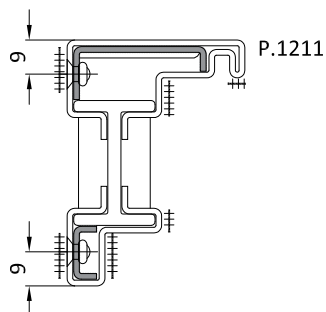

P.1211

TIG welding with filler material in the areas indicated with #####

Seal all the external contact surfaces with silicone our SL0019

 Countersunk rivets Ø 4

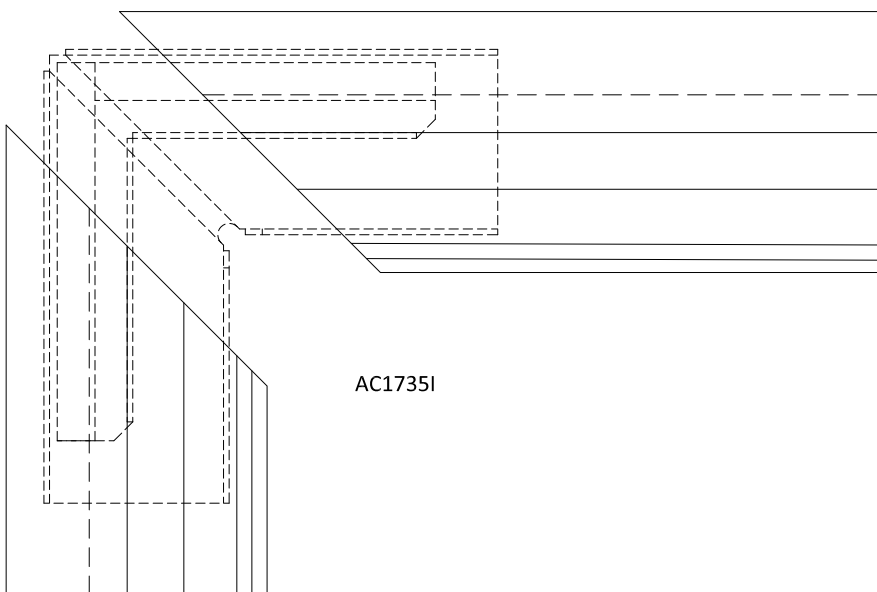

AC1735I

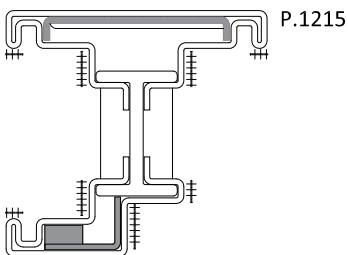

P.1215

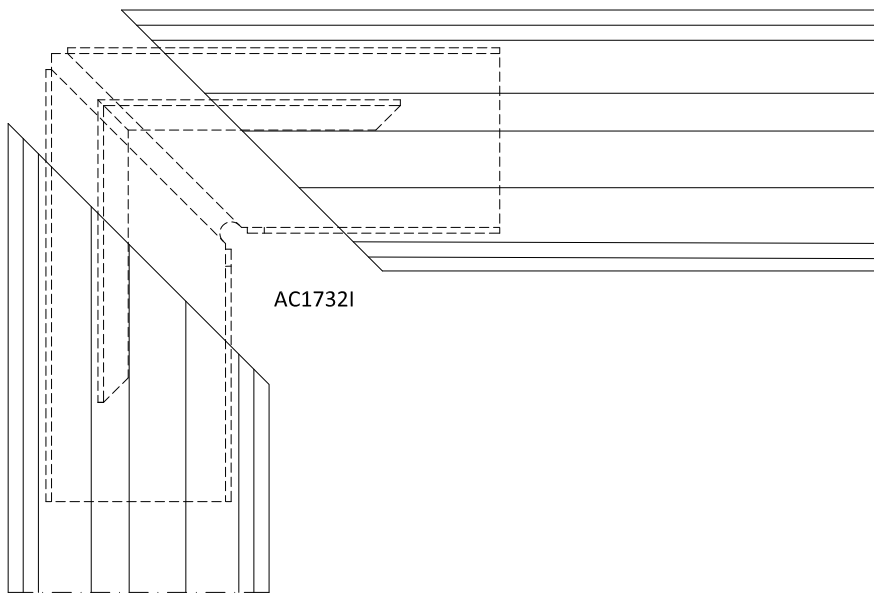

AC1732I

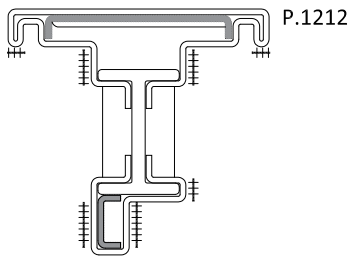

P.1212

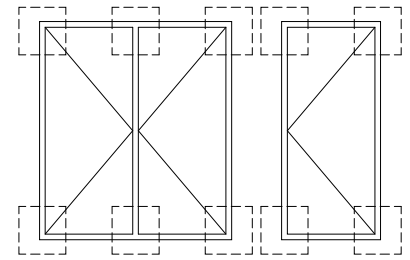

Saldare a TIG con materiale di riporto nelle zone indicate con +++++

Sigillare tutte le superfici di contatto esterne con silicone o SL0019

 Rivetti svasati Ø 4

*TIG welding with filler material in the areas indicated with +++++*

*Seal all the external contact surfaces with silicone our SL0019*

 Countersunk rivets Ø 4

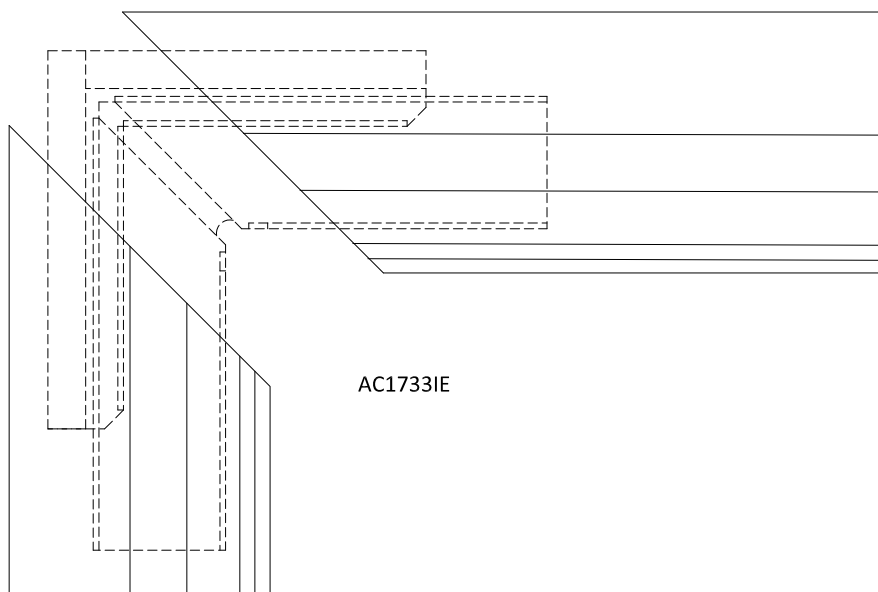

AC1733IE

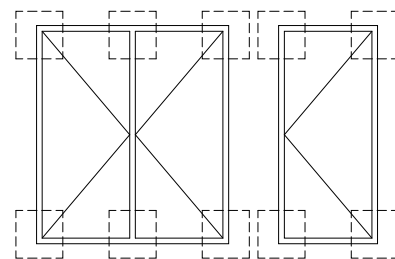
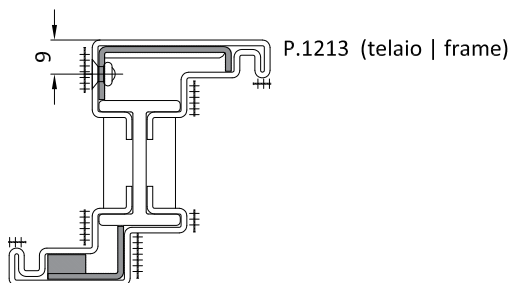

Saldare a TIG con materiale di riporto nelle zone indicate con #####

Sigillare tutte le superfici di contatto esterne con silicone o SL0019

 Rivetti svasati Ø 4

*TIG welding with filler material in the areas indicated with #####*

*Seal all the external contact surfaces with silicone our SL0019*

 Countersunk rivets Ø 4

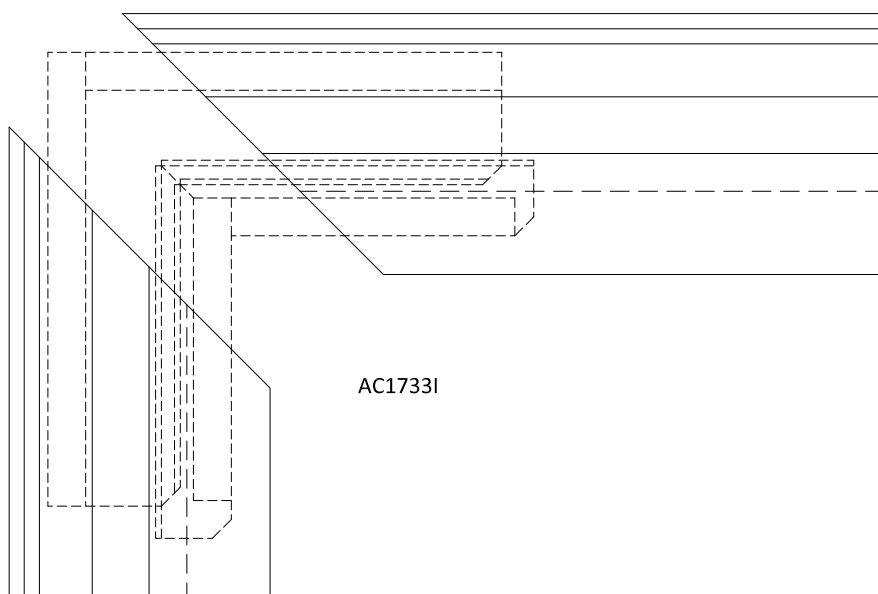

AC1733I

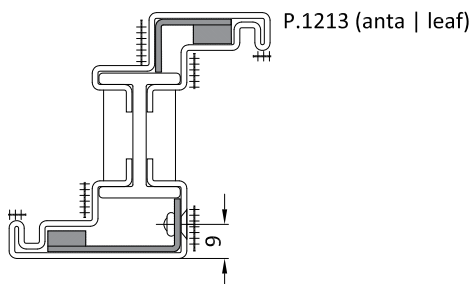

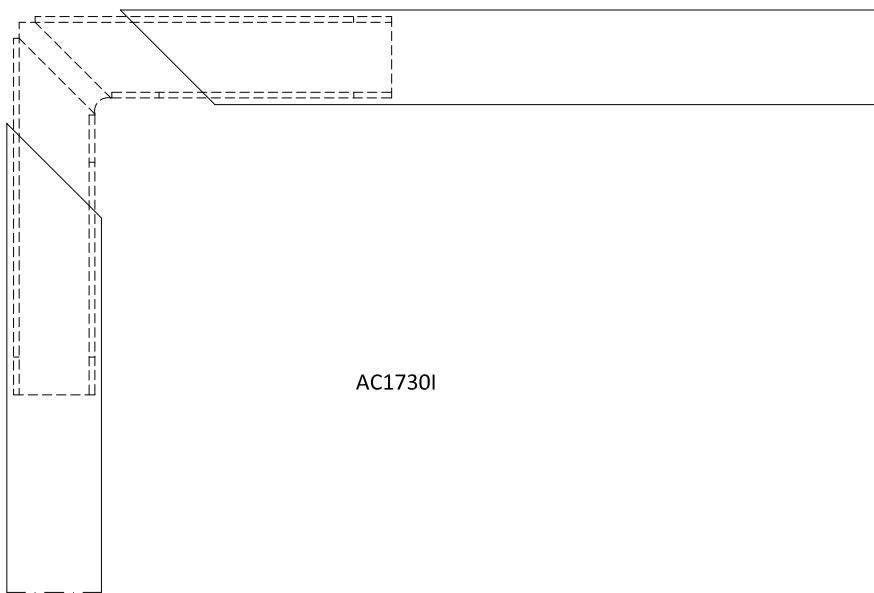

AC1730I

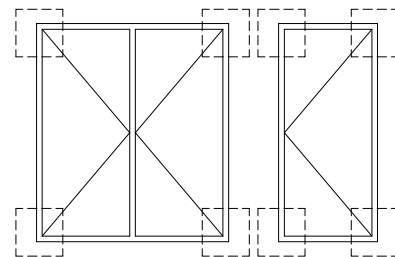

Saldare a TIG con materiale di riporto nelle zone indicate con #####

Sigillare tutte le superfici di contatto esterne con silicone o SL0019

 Rivetti svasati Ø 4

*TIG welding with filler material in the areas indicated with #####*

*Seal all the external contact surfaces with silicone our SL0019*

 Countersunk rivets Ø 4

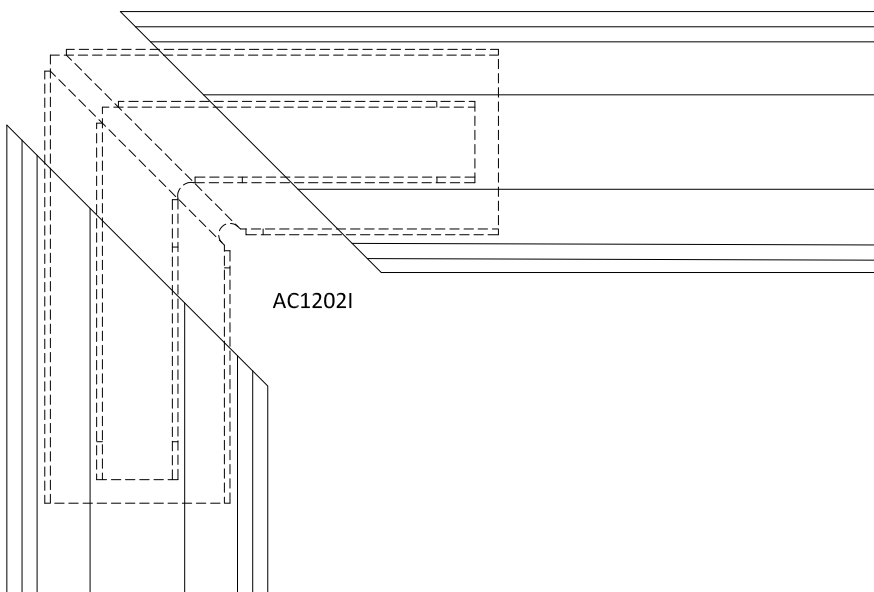
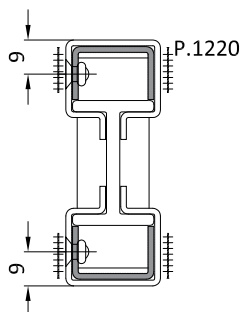

AC1202I

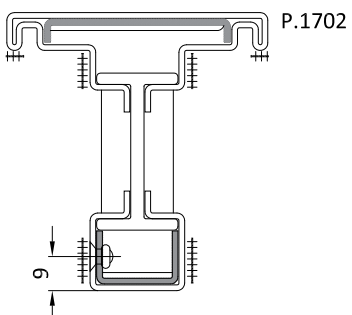

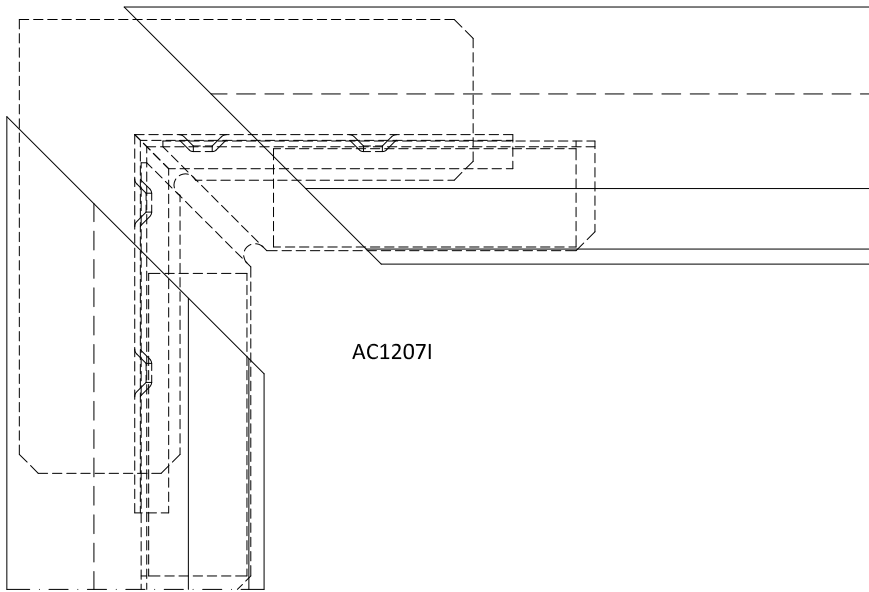

AC1207I

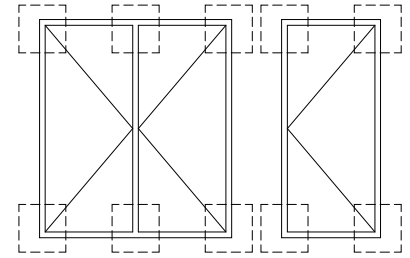

Saldare a TIG con materiale di riporto nelle zone indicate con +++++

Sigillare tutte le superfici di contatto esterne con silicone o SL0019

 Rivetti svasati Ø 4

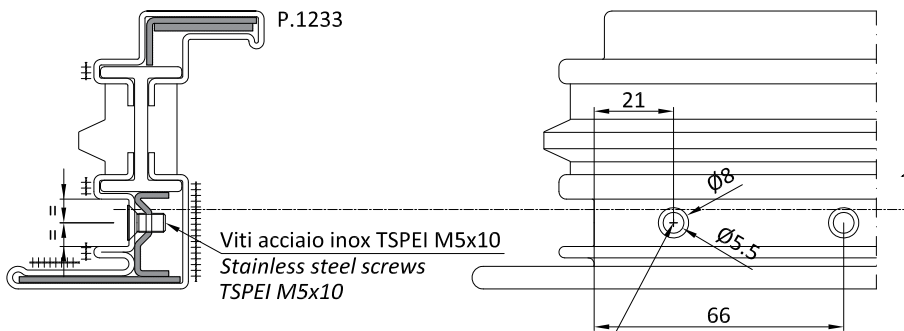

P.1233

Viti acciaio inox TSPEI M5x10  
Stainless steel screws  
TSPEI M5x10

TIG welding with filler material in the areas indicated with +++++

Seal all the external contact surfaces with silicone our SL0019

 Countersunk rivets Ø 4

Fori imbutiti per Viti TSPEI M5x10 con stampo AT1233  
Deep-drawn holes for TSPEI M5x10 screws with  
mould AT1233

Saldare a TIG con materiale di riporto nelle zone indicate con +++++

TIG welding with filler material in the areas indicated with +++++

Sigillare tutte le superfici di contatto esterne con silicone o SL0019

Seal all the external contact surfaces with silicone or SL0019

 Rivetti svasati Ø 4

 Countersunk rivets Ø 4

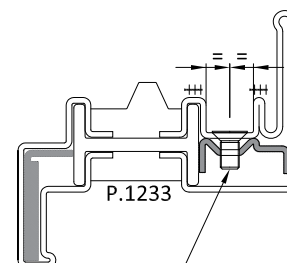
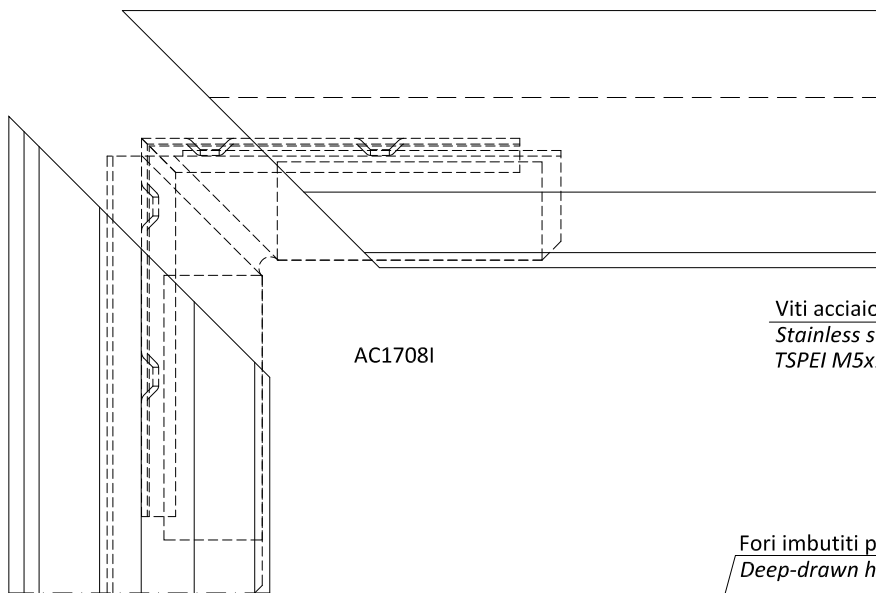
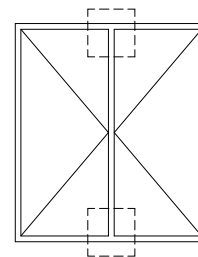

Viti acciaio inox TSPEI M5x10  
Stainless steel screws  
TSPEI M5x10

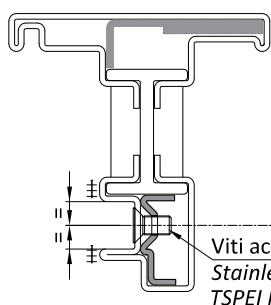

P.1724

Viti acciaio inox TSPEI M5x10  
Stainless steel screws  
TSPEI M5x10

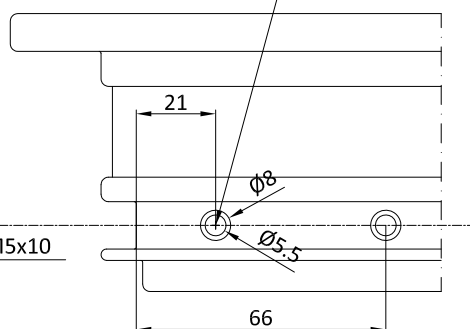

Fori imbutiti per Viti TSPEI M5x10 con stampo AT1233  
Deep-drawn holes for TSPEI M5x10 screws with mould AT1233

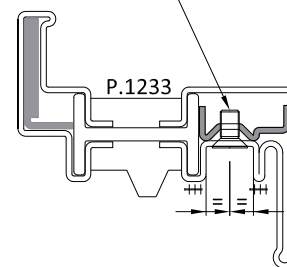
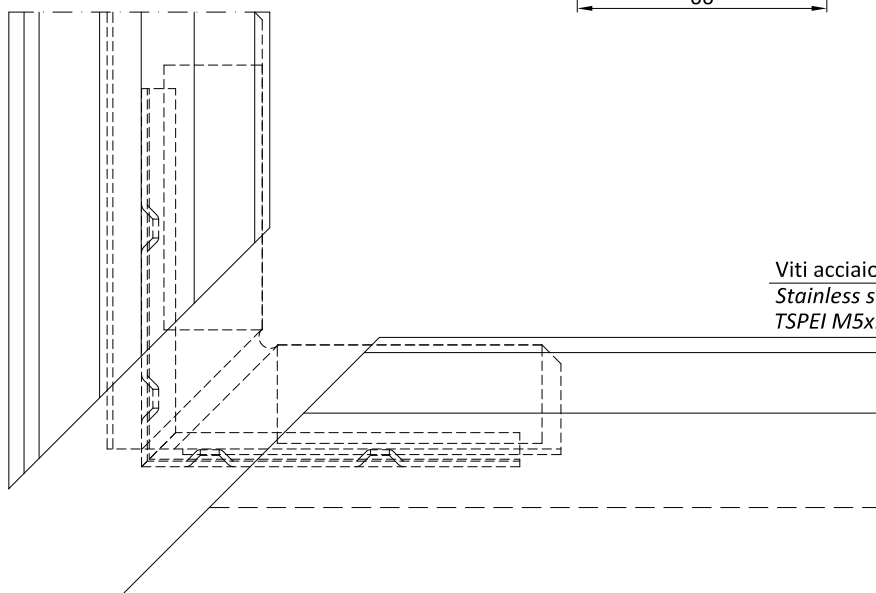

Viti acciaio inox TSPEI M5x10  
Stainless steel screws  
TSPEI M5x10



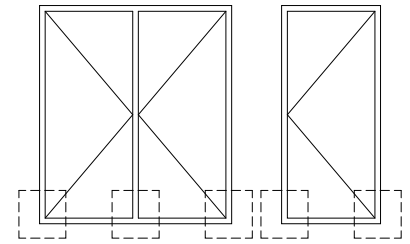
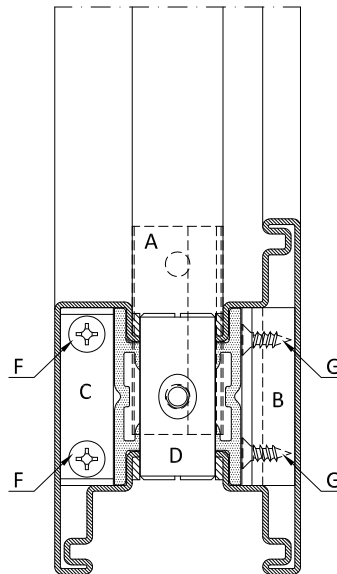
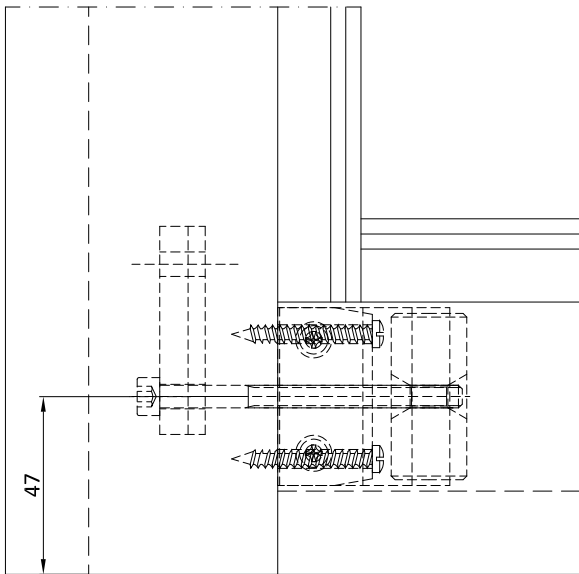

Saldare a TIG con materiale di riporto nelle zone indicate con

Sigillare tutte le superfici di contatto con silicone o SL0019

- A) Inserto di fissaggio
- B) Cavallotto di allineamento lato esterno
- C) Cavallotto di allineamento lato interno
- D) Tirante per cavallotto
- E) Vite acciaio inox TCEI M6x80
- F) Vite acciaio inox TC 4.8x38
- G) Vite autofilettante TSTC 3.9x9.5

TIG welding with filler material in the areas indicated with

Seal all the external contact surfaces with silicone or SL0019

- A) Anchoring insert
- B) U-bolt for alignment outer side
- C) U-bolt for alignment inner side
- D) Adapter sleeve for U-bolt
- E) Stainless steel screws TCEI M6x80
- F) Stainless steel screws TC 4.8x38
- G) Self-threading screws TSTC 3.9x9.5

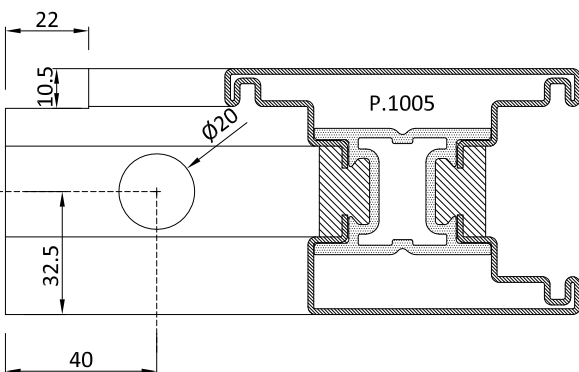
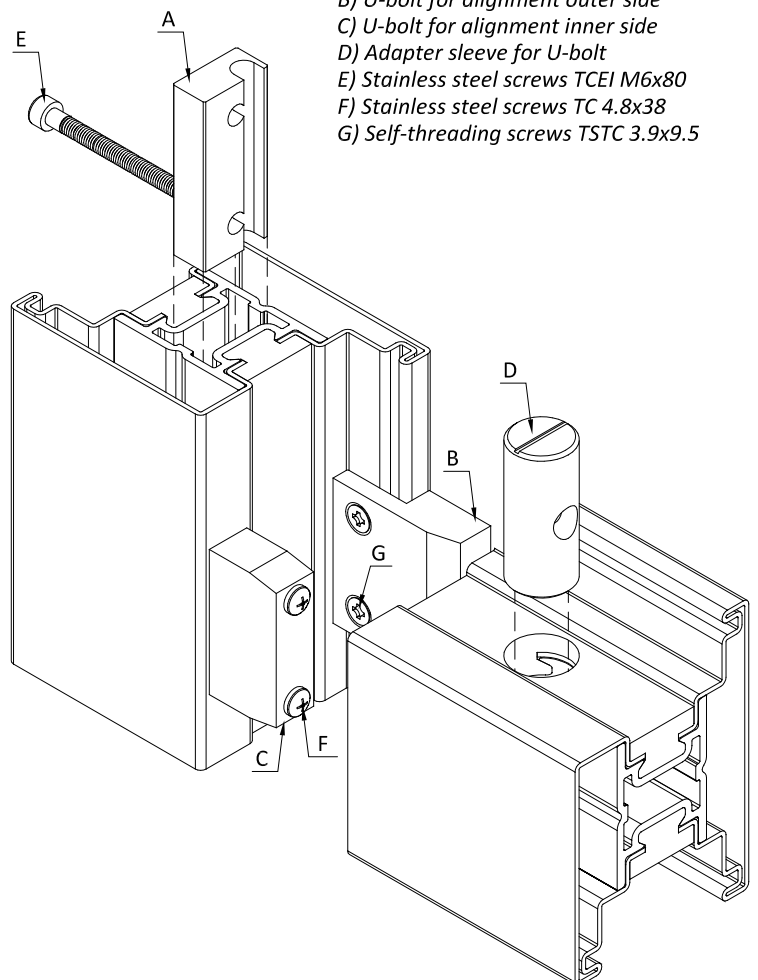
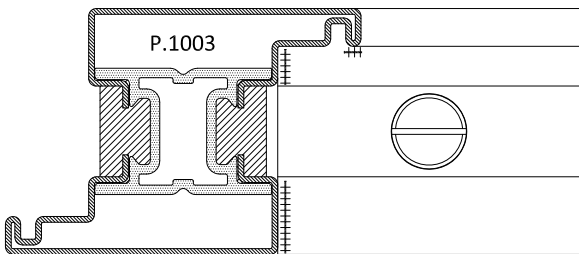
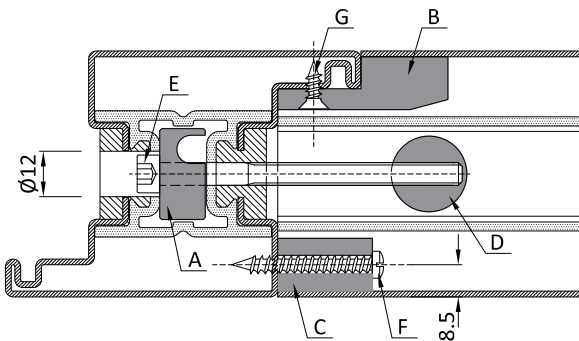

Lavorazione valida per profili P.1001 - P.1002 - 1005  
Tooling valid for profiles P.1001 - P.1002 - P.1005

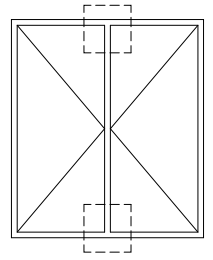
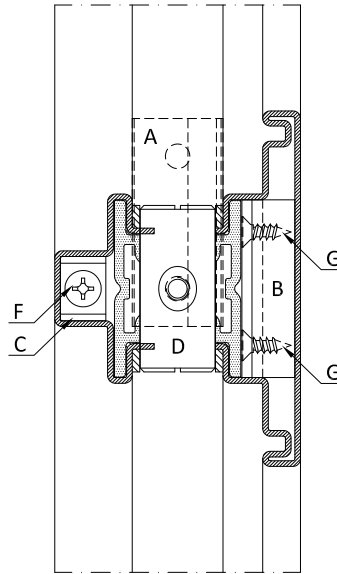
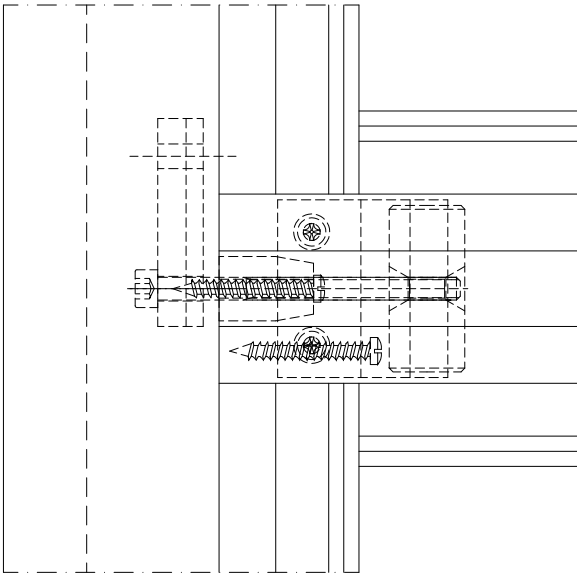

Saldare a TIG con materiale di riporto nelle zone indicate con +-----+

Sigillare tutte le superfici di contatto con silicone o SL0019

- A) Inserto di fissaggio
- B) Cavallotto di allineamento lato esterno
- C) Cavallotto di allineamento lato interno
- D) Tirante per cavallotto
- E) Vite acciaio inox TCEI M6x80
- F) Vite acciaio inox TC 4.8x38
- G) Vite autofilettante TSTC 3.9x9.5

TIG welding with filler material in the areas indicated with +-----+

Seal all the external contact surfaces with silicone or SL0019

- A) Anchoring insert
- B) U-bolt for alignment outer side
- C) U-bolt for alignment inner side
- D) Adapter sleeve for U-bolt
- E) Stainless steel screws TCEI M6x80
- F) Stainless steel screws TC 4.8x38
- G) Self-threading screws TSTC 3.9x9.5

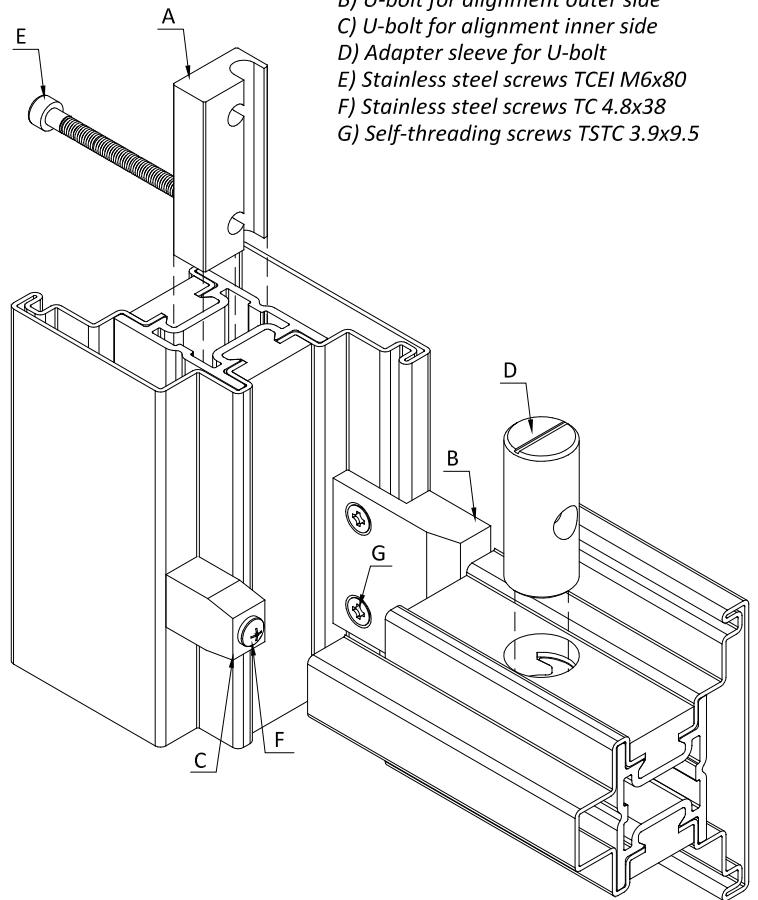
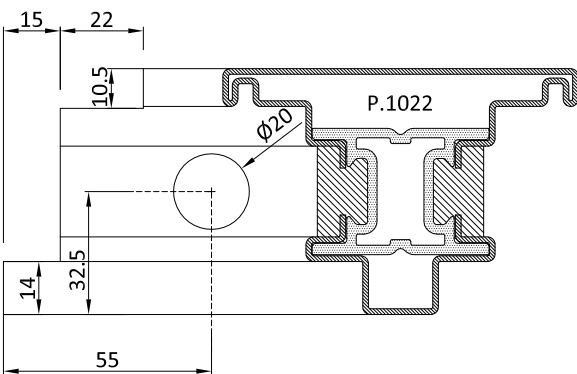
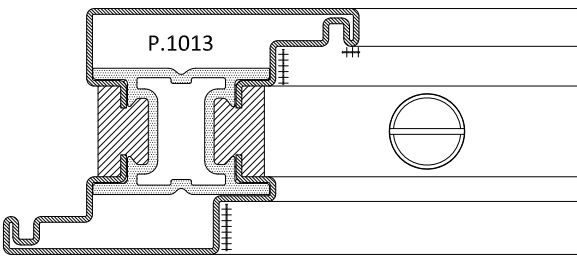
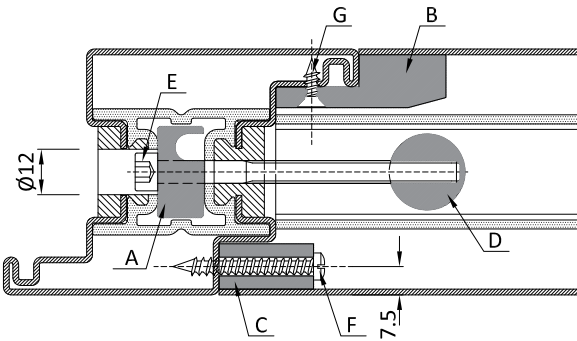

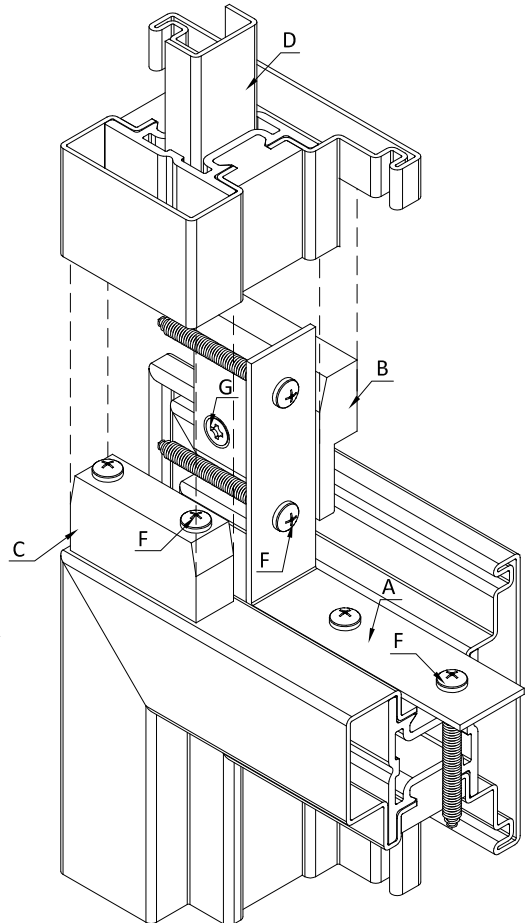
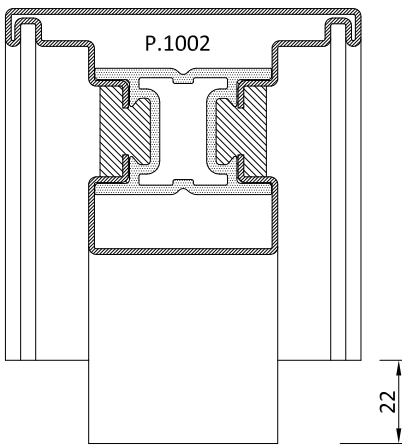
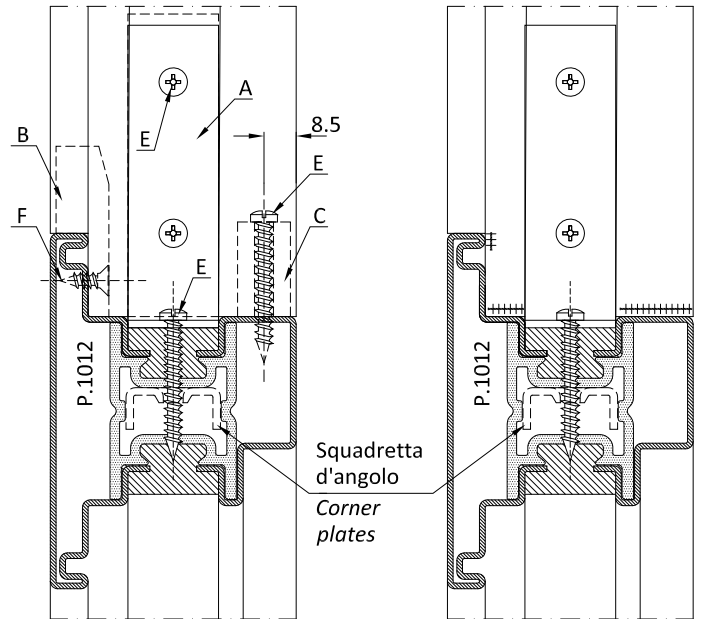
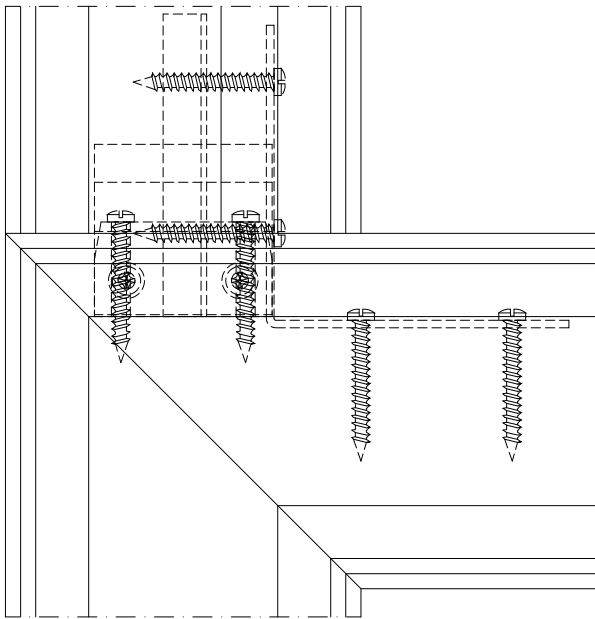
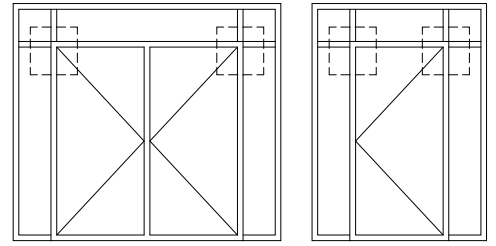
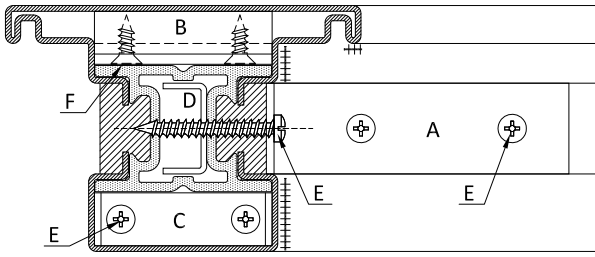

Saldare a TIG con materiale di riporto nelle zone indicate con +++++

TIG welding with filler material in the areas indicated with +++++

Sigillare tutte le superfici di contatto con silicone o SL0019

Seal all the external contact surfaces with silicone or SL0019

- A) Squadretta giunzione 90°
- B) Cavallotto di allineamento lato esterno
- C) Cavallotto di allineamento lato interno
- D) Rinforzo interno
- E) Vite acciaio inox TC 4.8x38
- F) Vite autofilettante TSTC 3.9x9.5

- A) Corner bracket 90°
- B) U-bolt for alignment outer side
- C) U-bolt for alignment inner side
- D) Internal reinforcement
- E) Stainless steel screws TC 4.8x38
- F) Self-threading screws TSTC 3.9x9.5

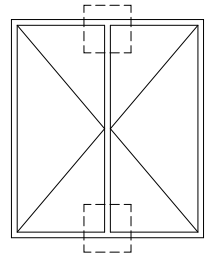
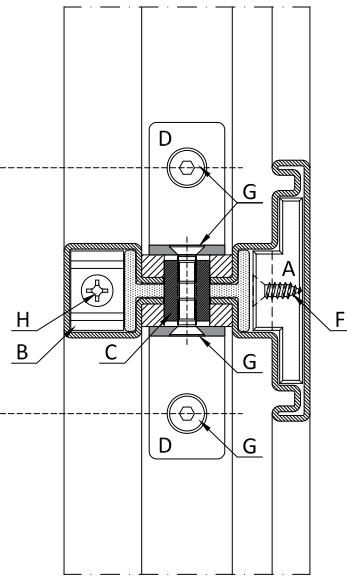
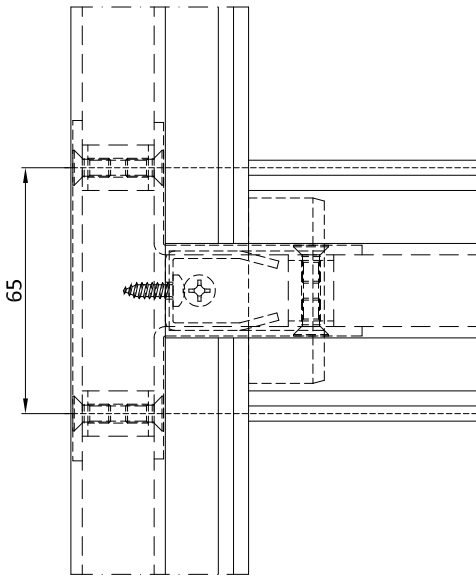

Saldare a TIG con materiale di riporto nelle zone indicate con

Sigillare tutte le superfici di contatto con silicone o SL0019

- A) Cavallotto di allineamento lato interno
- B) Cavallotto di allineamento lato esterno
- C) Bussola filettata
- D) Squadretta di tiraggio
- E) Piastrina di fissaggio
- F) Vite acciaio inox TPS 4.2x13
- G) Vite acciaio inox TSPEI M5x10
- H) Vite autofilettante TC 4.2x13

TIG welding with filler material in the areas indicated with

Seal all the external contact surfaces with silicone or SL0019

- A) U-bolt for alignment inner side
- B) U-bolt for alignment outer side
- C) Threaded bush
- D) Corner bracket
- E) Fixing plate
- F) Stainless steel screws TPS 4.2x13
- G) Stainless steel screws TSPEI M5x10
- H) Self-threading screws TC 4.2x13

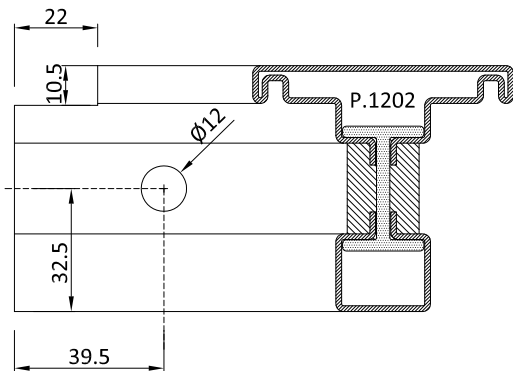
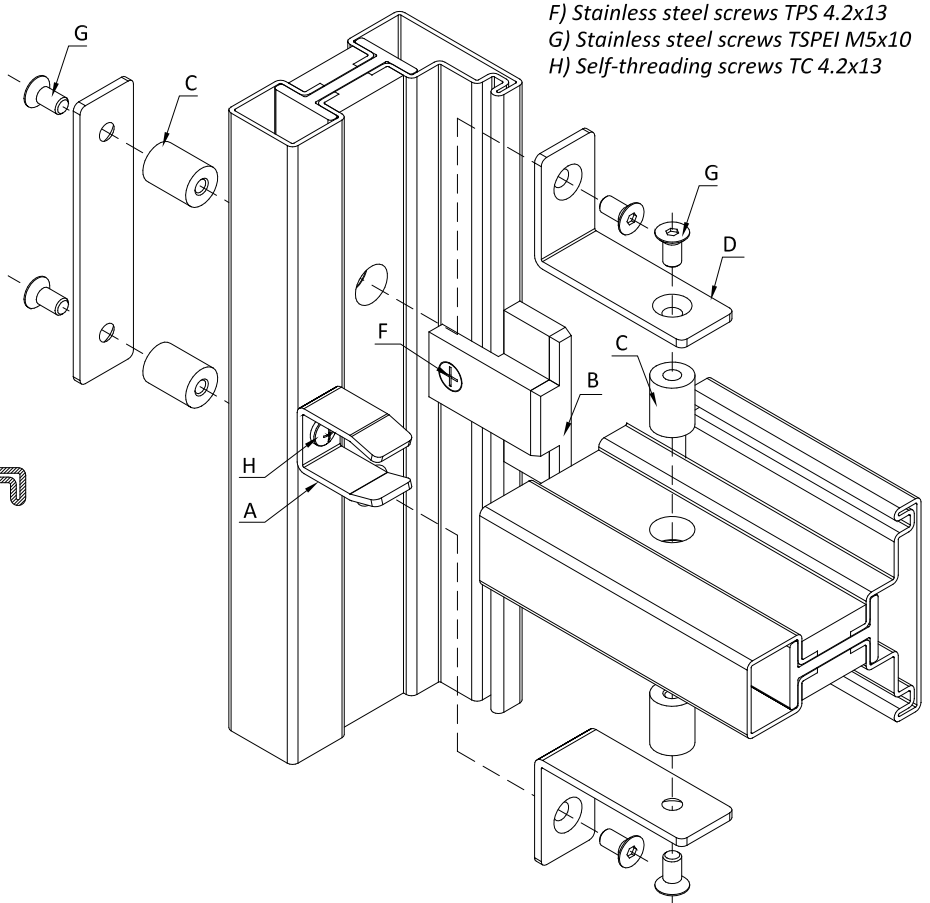
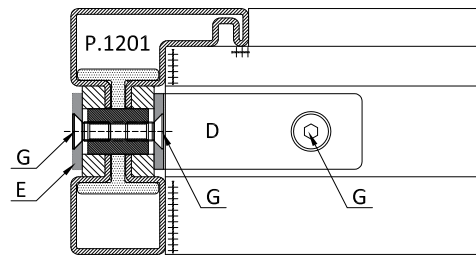
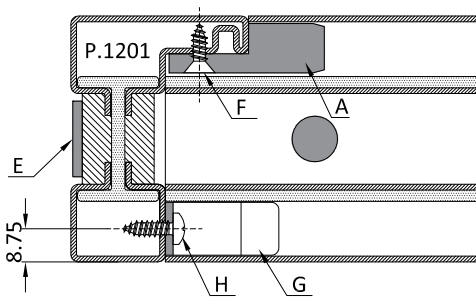

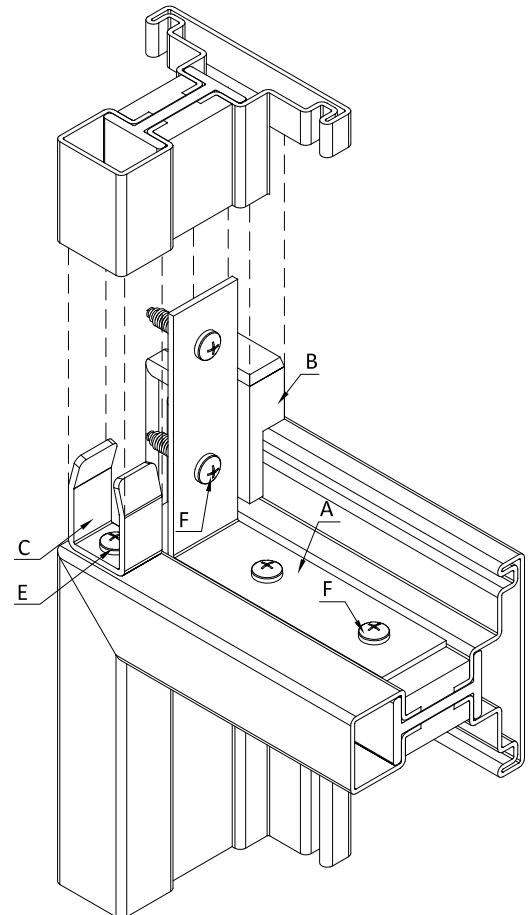
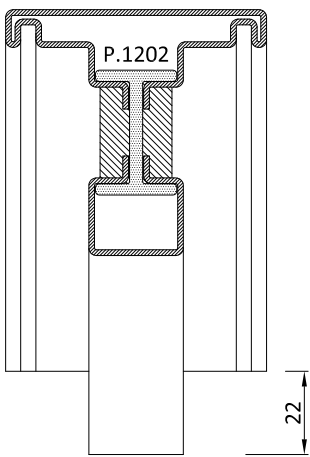
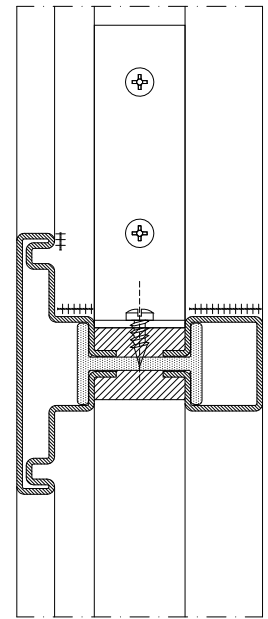
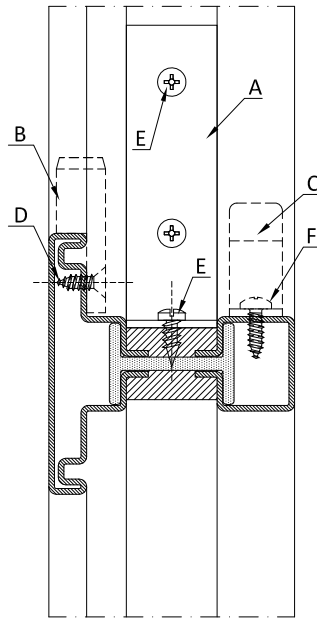
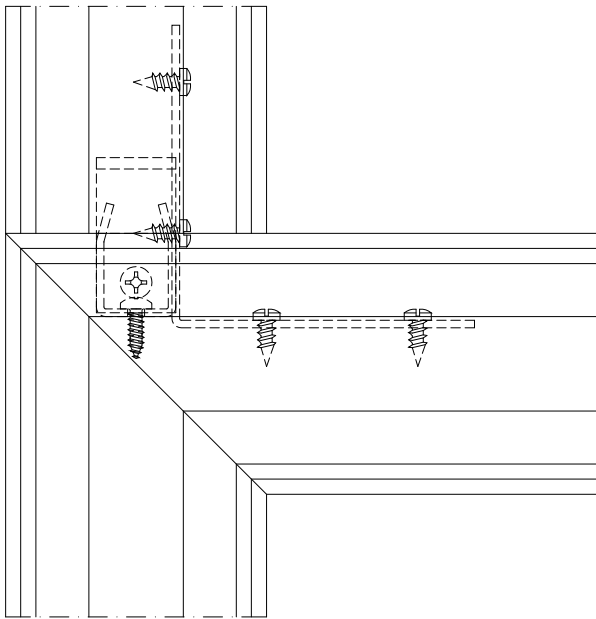
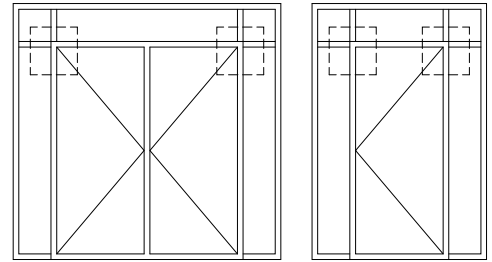
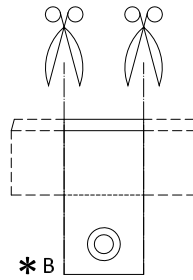
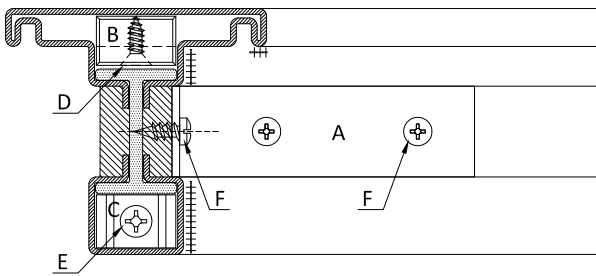

Saldare a TIG con materiale di riporto nelle zone indicate con +++++

TIG welding with filler material in the areas indicated with +++++

Sigillare tutte le superfici di contatto con silicone o SL0019

Seal all the external contact surfaces with silicone or SL0019

- A) Squadretta giunzione 90°
- B) Cavallo di allineamento lato esterno
- C) Cavallo di allineamento lato interno
- D) Vite acciaio inox TPS 4.2x13
- E) Vite autofilettante TC 4.2x13
- F) Vite autofilettante TE 4.8x20

- A) Corner bracket 90°
- B) U-bolt for alignment outer side
- C) U-bolt for alignment inner side
- D) Stainless steel screws TPS 4.2x13
- E) Self-threading screws TC 4.2x13
- F) Self-threading screws TE 4.8x20

\* Tagliare le alette del cavallo B come da disegno

\* Angles of U-connection piece B have to be cut according the drawing

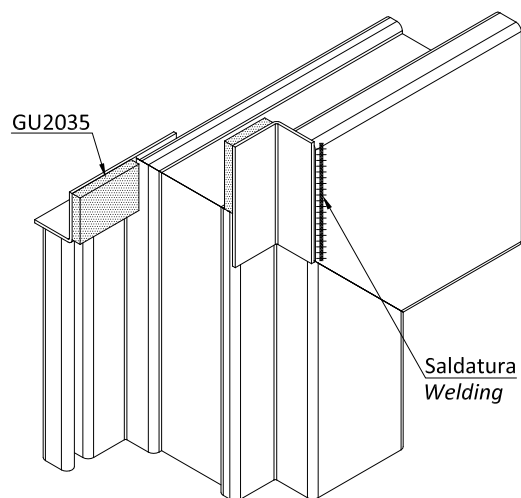
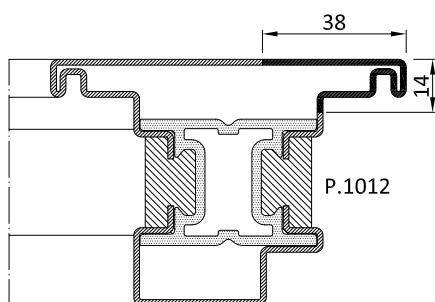
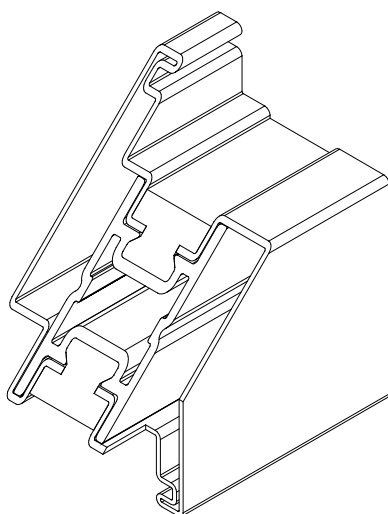
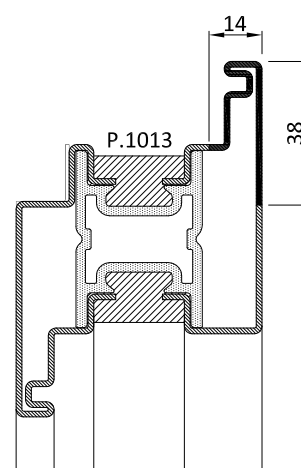
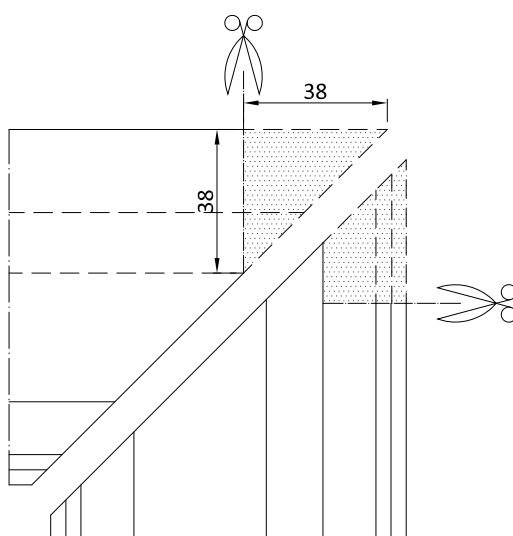
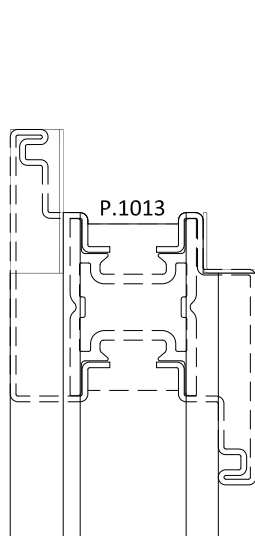
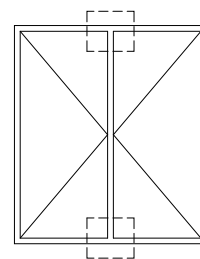
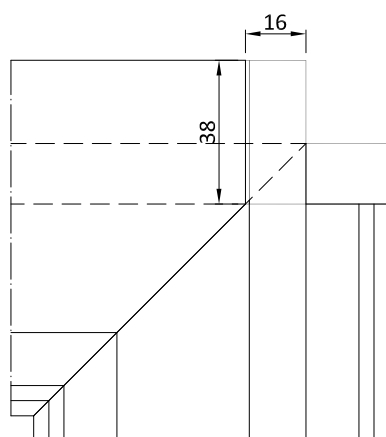
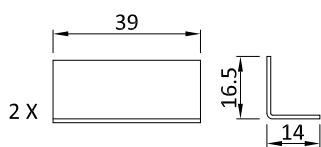

Nota: Saldare e sigillare l'accessorio secondo la tipologia e la mano di apertura  
Note: Weld and seal the AC1014 according to the typology and the opening

Nota: i fondini sono forniti di dimensioni maggiori da rifilare dopo la saldatura  
Note: Ending caps are provided in larger dimensions. They have to be trimmed after welding

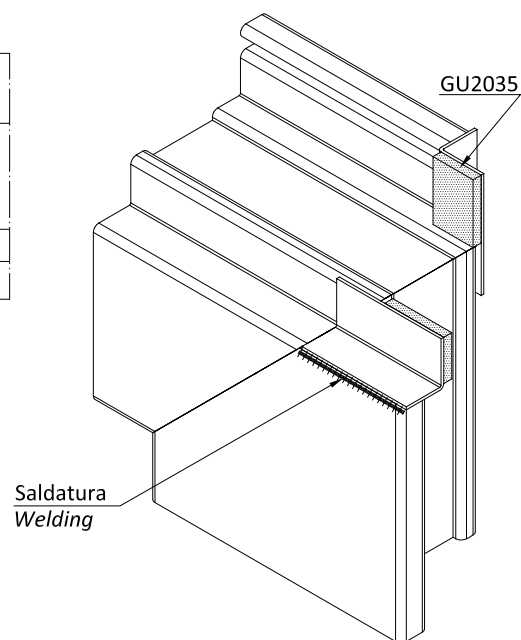
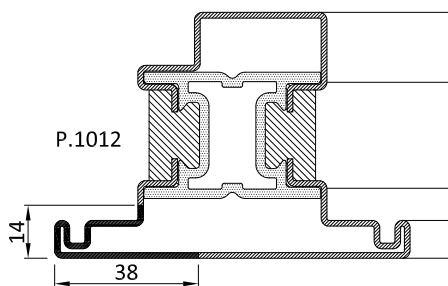
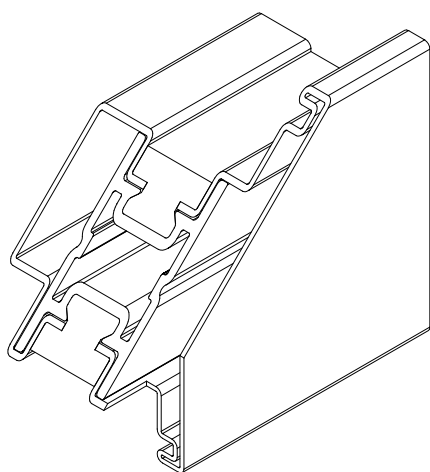
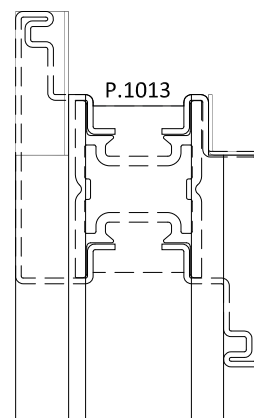
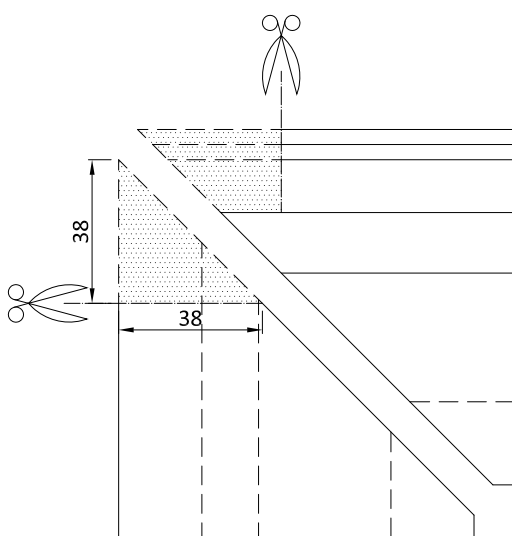
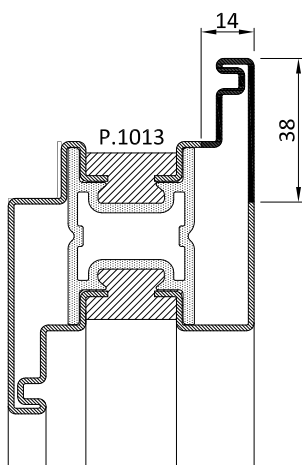
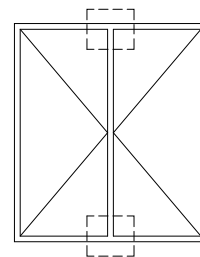
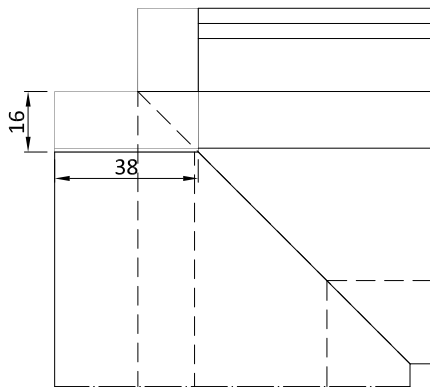
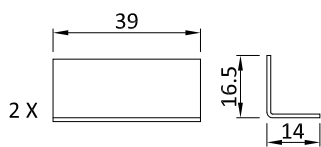

Nota: Saldare e sigillare l'accessorio secondo la tipologia e la mano di apertura  
Note: Weld and seal the AC1014 according to the typology and the opening

Nota: i fondini sono forniti di dimensioni maggiori da rifilare dopo la saldatura  
Note: Ending caps are provided in larger dimensions. They have to be trimmed after welding

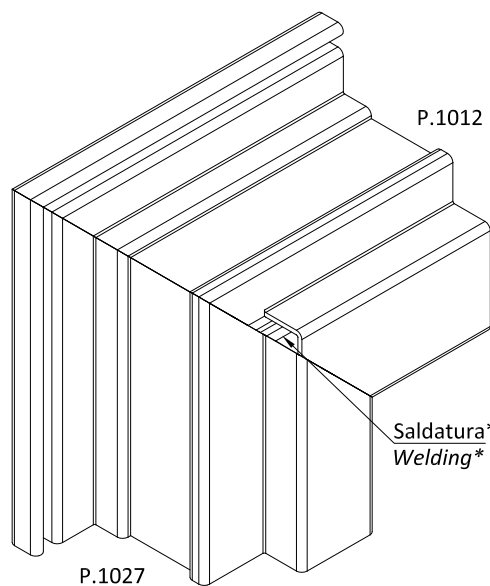
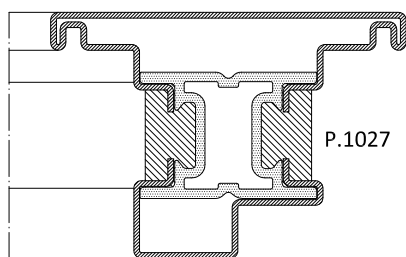
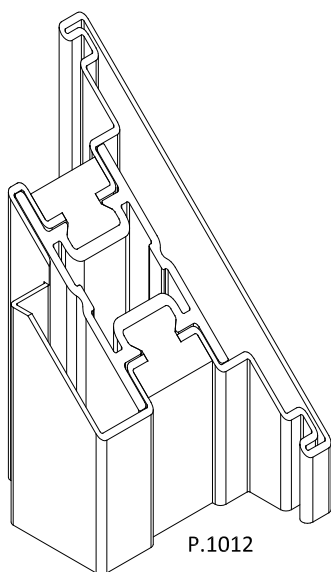
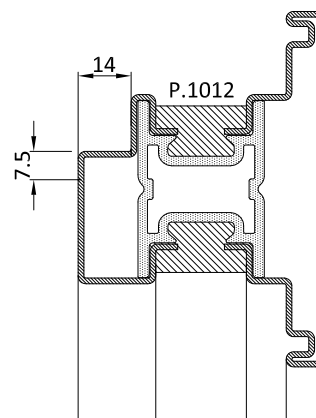
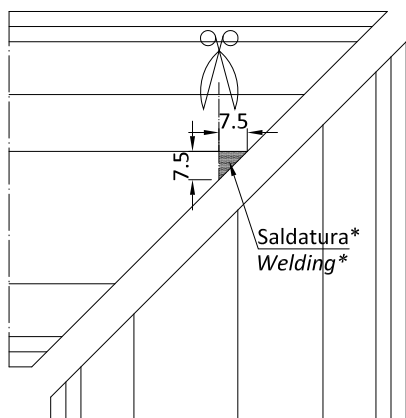
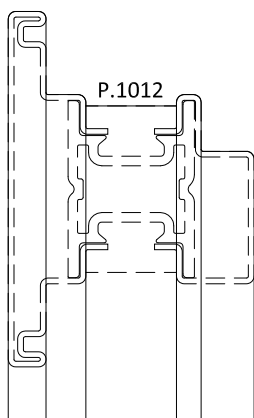
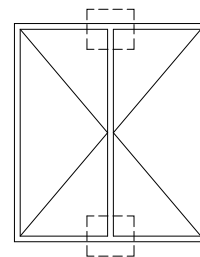
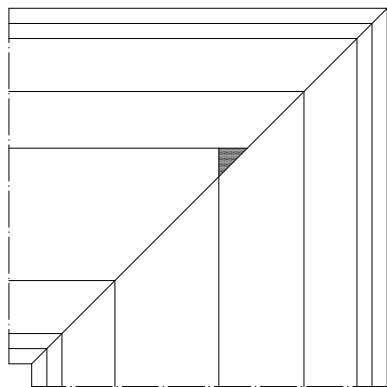

\* Saldare con materiale di riporto  
\* Welding with filler material



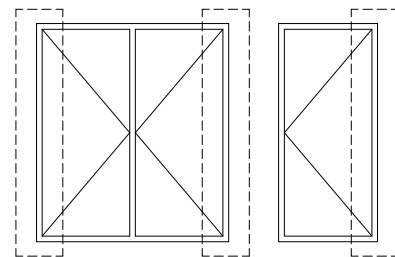

- A) Corpo cerniera A
- B) Corpo cerniera B
- C) Perno
- D) Distanziatore
- E) Tappo a vite
- F) Boccola antifrizione
- G) Distanziatore
- H) Rinforzi interni
- I) Distanziale di regolazione
- L) Viti acciaio inox TSPEI M6 x 16
- M) Vite acciaio inox testa a bottone M6 x 10
- N) Spina inox Ø 6 x 10 da inserire dopo la regolazione dell'anta
- O) Grano M5 x 6

- A) Body of the hinge A
- B) Body of the hinge B
- C) Pin
- D) Spacer
- E) Screw cap
- F) Antifriction bushing
- G) Spacer
- H) Internal reinforcements
- I) Regulating spacer
- L) Stainless steel screws TSPEI M6 x 16
- M) Stainless steel button head screws M6 x 10
- N) Stainless steel pin Ø 6 x 10 to insert after regulating the leaf
- O) Dowel M5x6

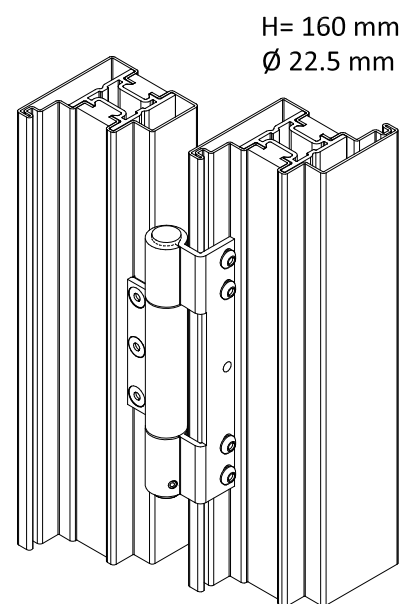
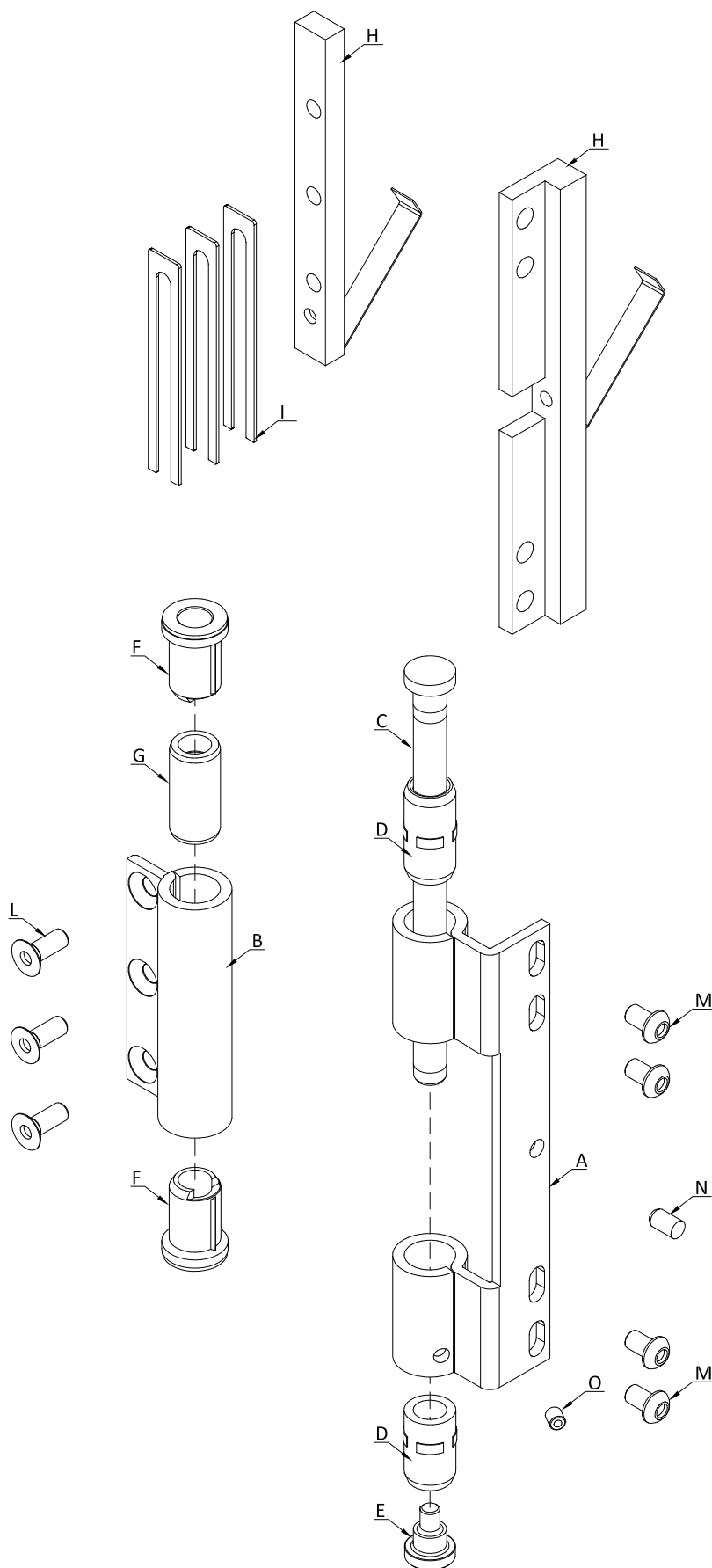



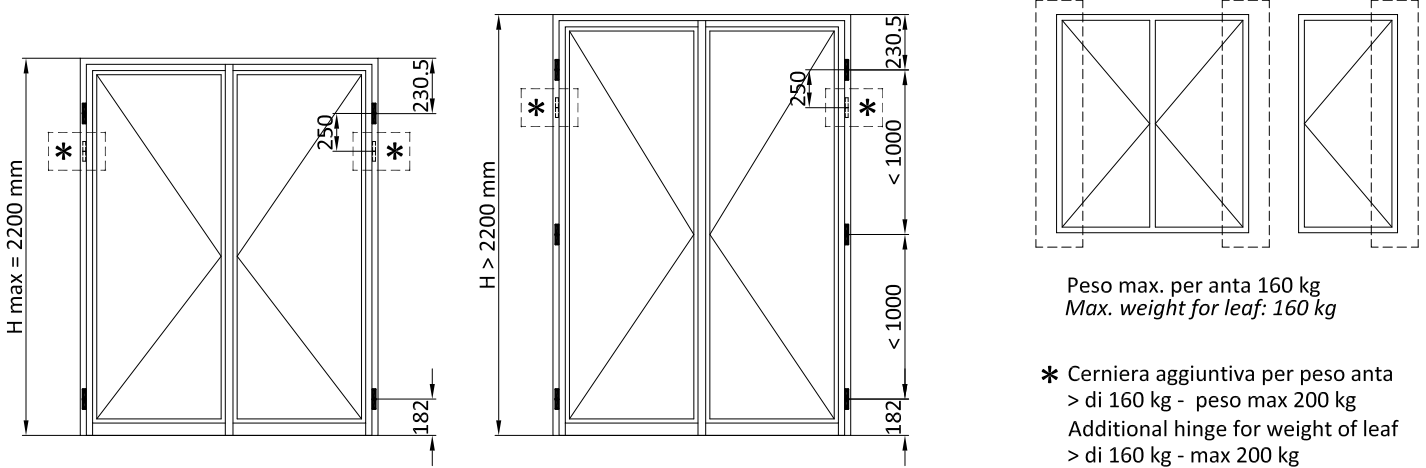

Peso max. per anta 160 kg  
Max. weight for leaf: 160 kg

\* Cerniera aggiuntiva per peso anta > di 160 kg - peso max 200 kg  
Additional hinge for weight of leaf > di 160 kg - max 200 kg

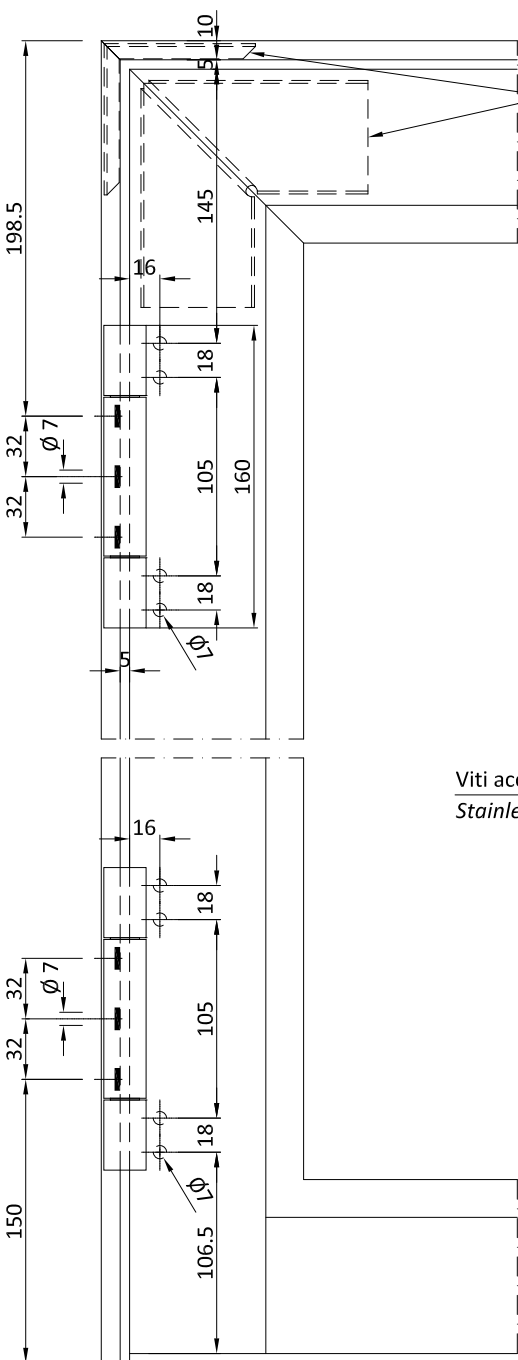

Squadrette angolo  
Corner plates

GE1001TT - tagliare la guarnizione dove interseca le cerniere  
GE1001TT - cut the gasket where the hinges cross

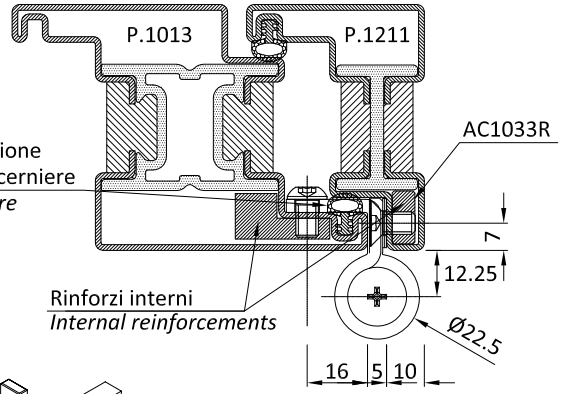

Rinforzi interni  
Internal reinforcements

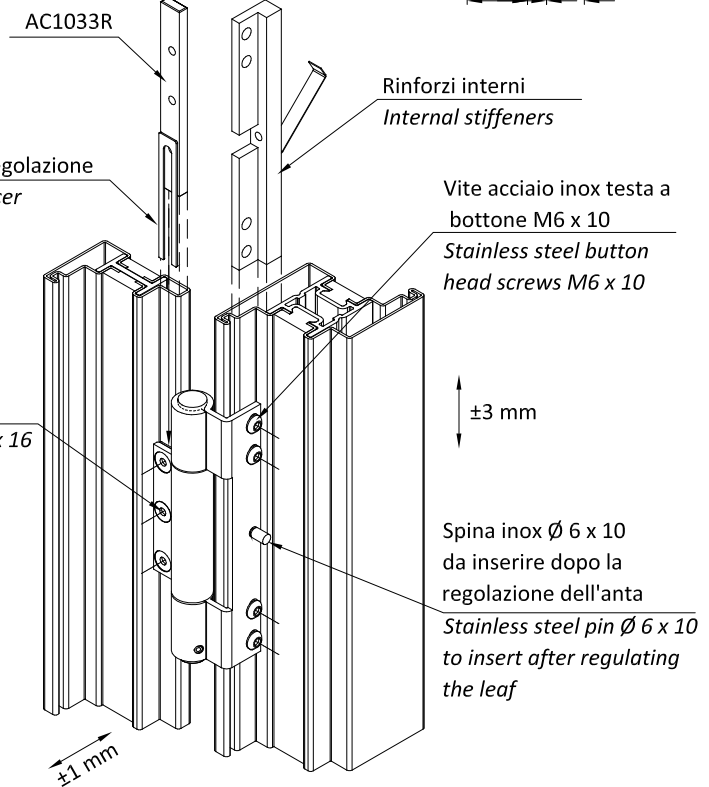

Distanziale di regolazione  
Regulating spacer

Rinforzi interni  
Internal stiffeners

Vite acciaio inox testa a bottone M6 x 10  
Stainless steel button head screws M6 x 10

Viti acciaio inox TSPEI M6 x 16  
Stainless steel screws TSPEI M6 x 16

Spina inox Ø 6 x 10 da inserire dopo la regolazione dell'anta  
Stainless steel pin Ø 6 x 10 to insert after regulating the leaf

- La lavorazione può essere effettuata anche in posizioni intermedie dell'altezza della porta.
- La lavorazione SX è speculare alla DX.
- La lavorazione è valida anche per le aperture esterne.
- Tooling can also be carried out in intermediate positions.
- Tooling is the same on the right and on the left.
- Tooling can be done also on external openings.

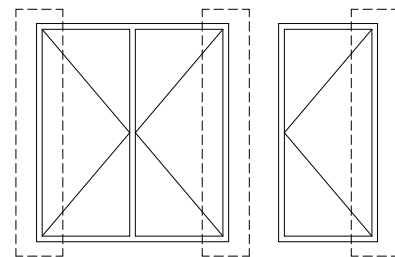
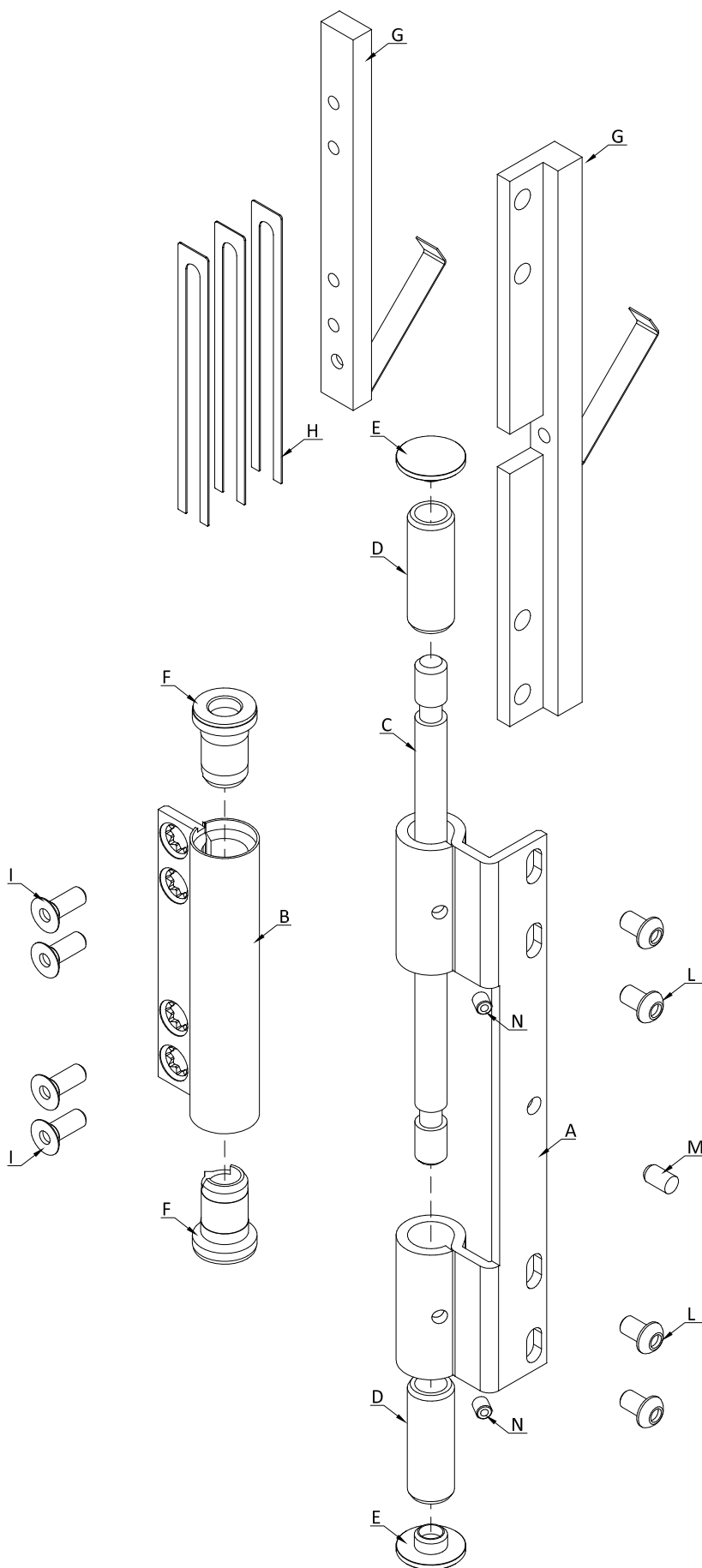

- A) Corpo cerniera A
- B) Corpo cerniera B
- C) Perno
- D) Distanziatore
- E) Tappo di finitura
- F) Boccola antifrizione
- G) Rinforzi interni
- H) Distanziale di regolazione
- I) Viti acciaio inox TSPEI M6 x 16
- L) Vite acciaio inox testa a bottone M6 x 10
- M) Spina inox Ø 6 x 10 da inserire dopo la regolazione dell'anta
- N) Grano M5 x 6

- A) Body of the hinge A
- B) Body of the hinge B
- C) Pin
- D) Spacer
- E) Ending cap
- F) Antifriction bushing
- G) Internal reinforcements
- H) Regulating spacer
- I) Stainless steel screws TSPEI M6 x 16
- L) Stainless steel button head screws M6 x 10
- M) Stainless steel pin Ø 6 x 10 to insert after regulating the leaf
- N) Dowel M5x6

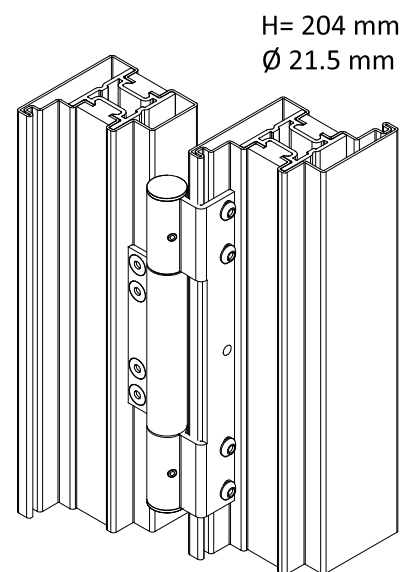

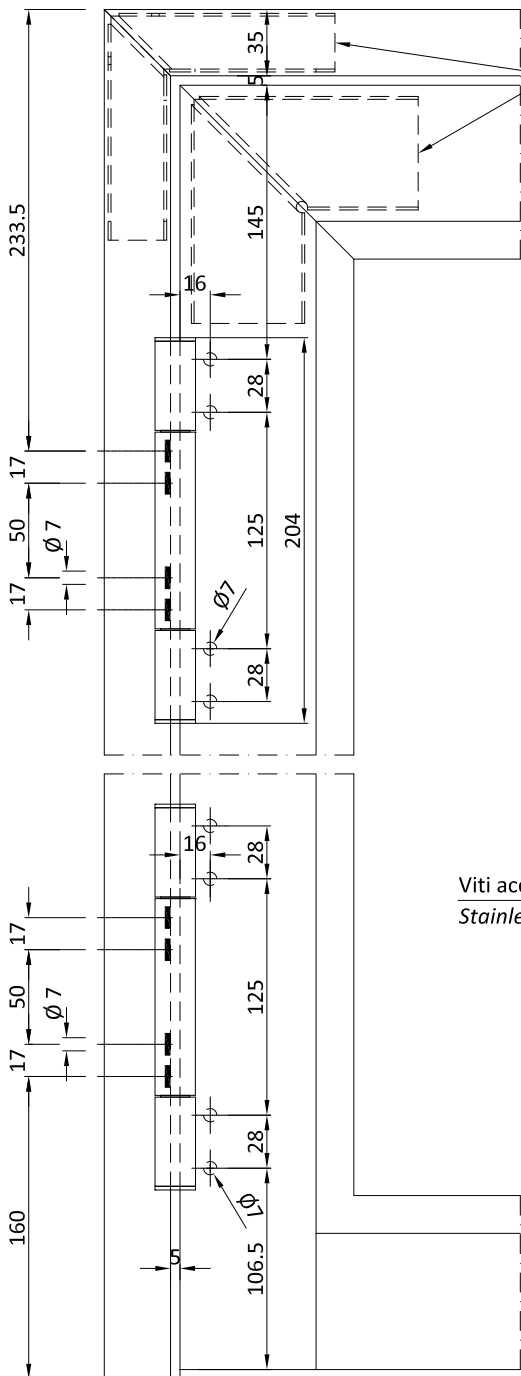
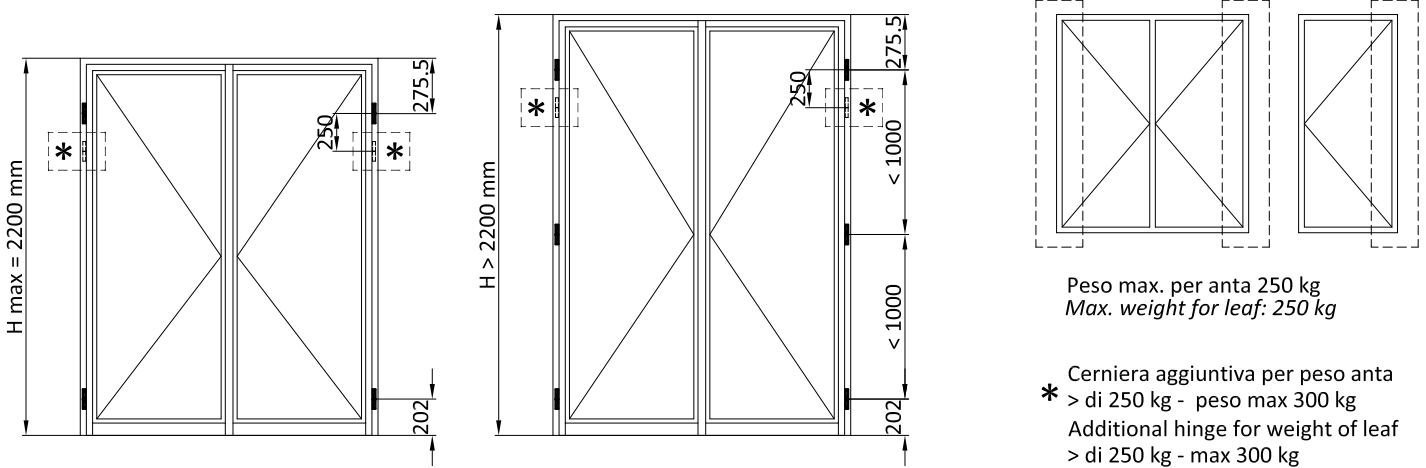

Squadrette angolo  
Corner plates

GE1001TT - tagliare la guarnizione dove interseca le cerniere  
GE1001TT - cut the gasket where the hinges cross

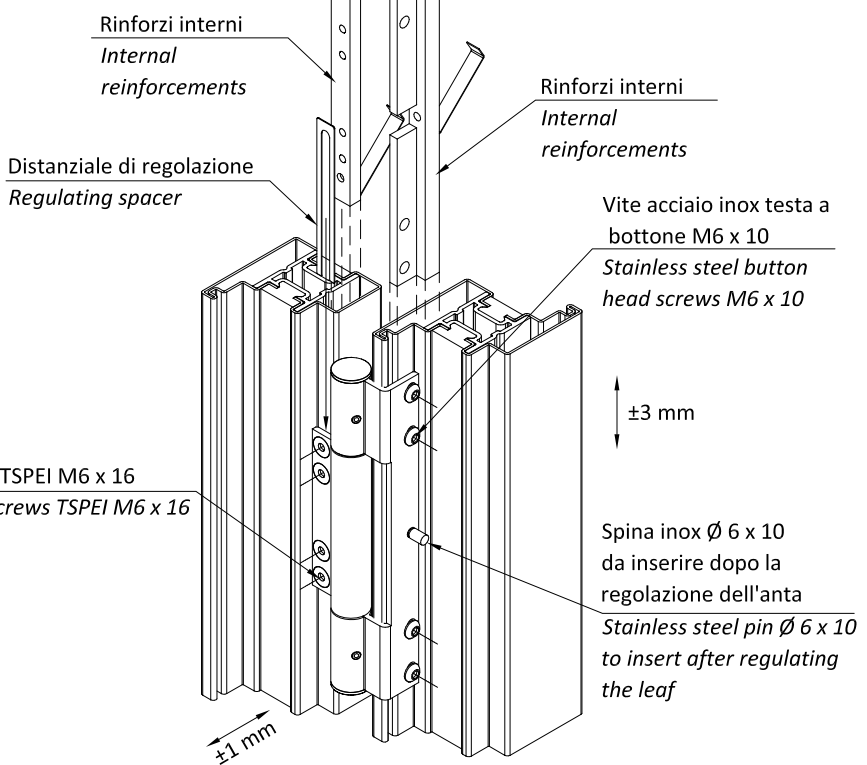
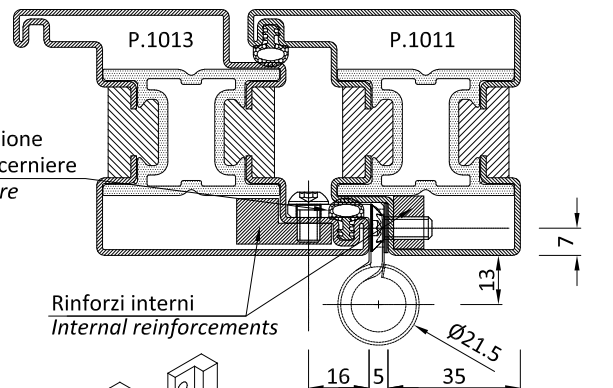

- La lavorazione può essere effettuata anche in posizioni intermedie dell'altezza della porta.
- La lavorazione SX è speculare alla DX.
- La lavorazione è valida anche per le aperture esterne.
- Tooling can also be carried out in intermediate positions.
- Tooling is the same on the right and on the left.
- Tooling can be done also on external openings.



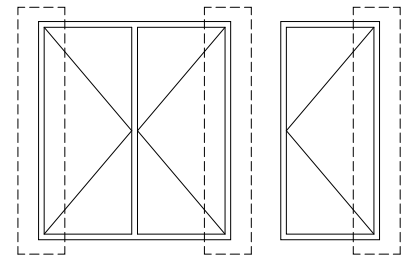
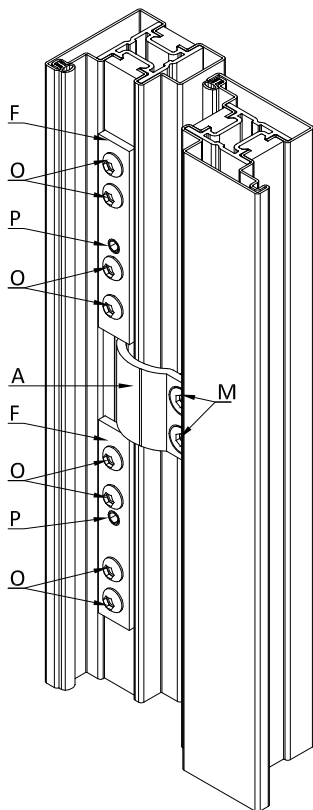

- A) Corpo cerniera A
- B) Corpo cerniera B
- C) Perno
- D) Cuscinetto
- E) Seger
- F) Piastra
- G) Contro-piastra A
- H) Contro-piastra B
- I) Spessore
- L) Staffa di fissaggio
- M) Contropiastra C
- N) n°2 x Vite TPEI M8x12 mm
- O) n°10 x Vite TCEI M8x30 mm
- P) Grano M10x25 mm punta conica

- A) Body hinge A
- B) Body hinge B
- C) Pin
- D) Bearing
- E) Seger
- F) Plate
- G) Retainer plate A
- H) Retainer plate B
- I) Shim
- L) Anchoring bracket
- M) Counter-plate C
- N) n° 2 x Screws TPEI M8x12 mm
- O) n°10 x Screws TCEI M8x30 mm
- P) Dowel M10x25 mm cone point

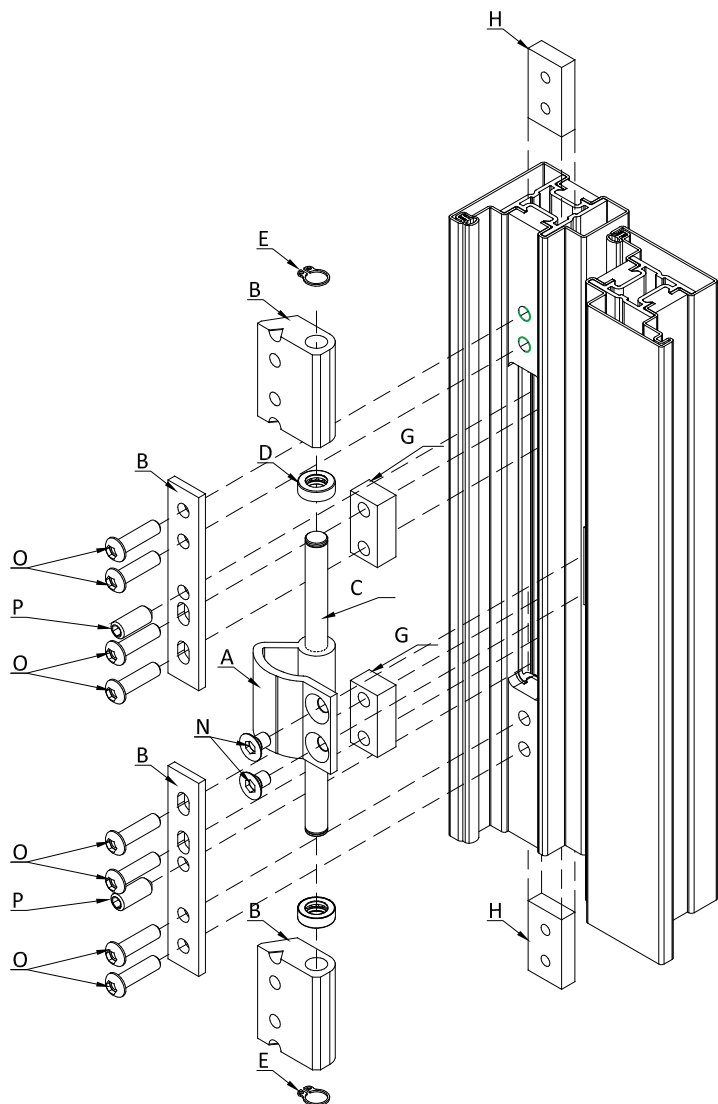
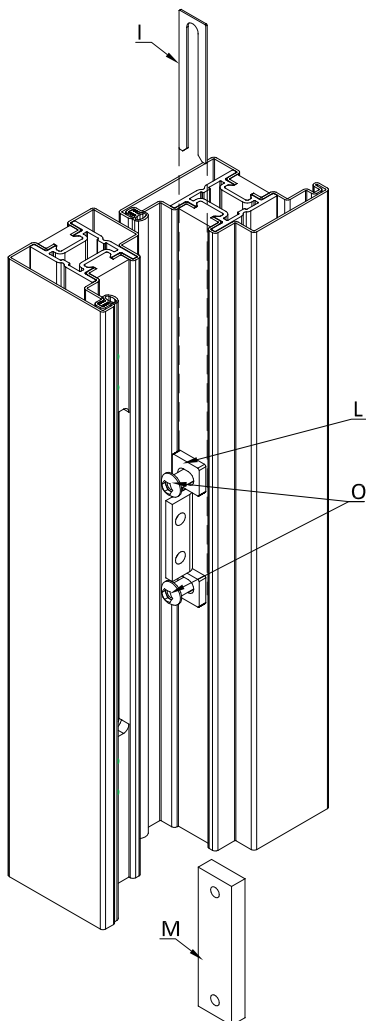

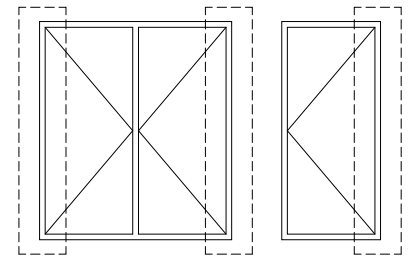
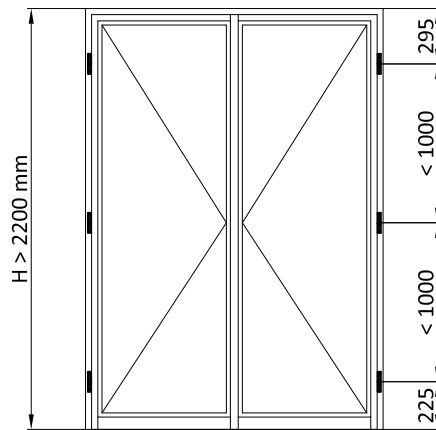
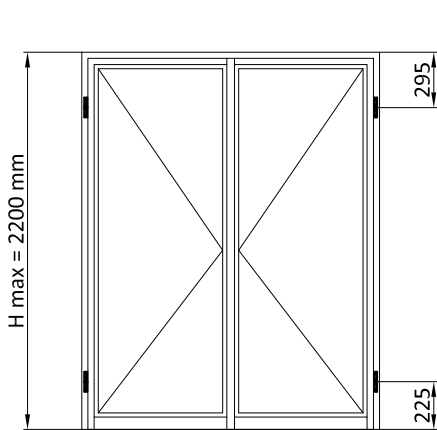

Peso max. per anta 180 kg  
Massima apertura 96°  
Max. weight for leaf: 180 kg  
Maximum opening 96°

Lavorazione eseguibile con fresa AT1058  
Tooling possible with milling cutter AT1058

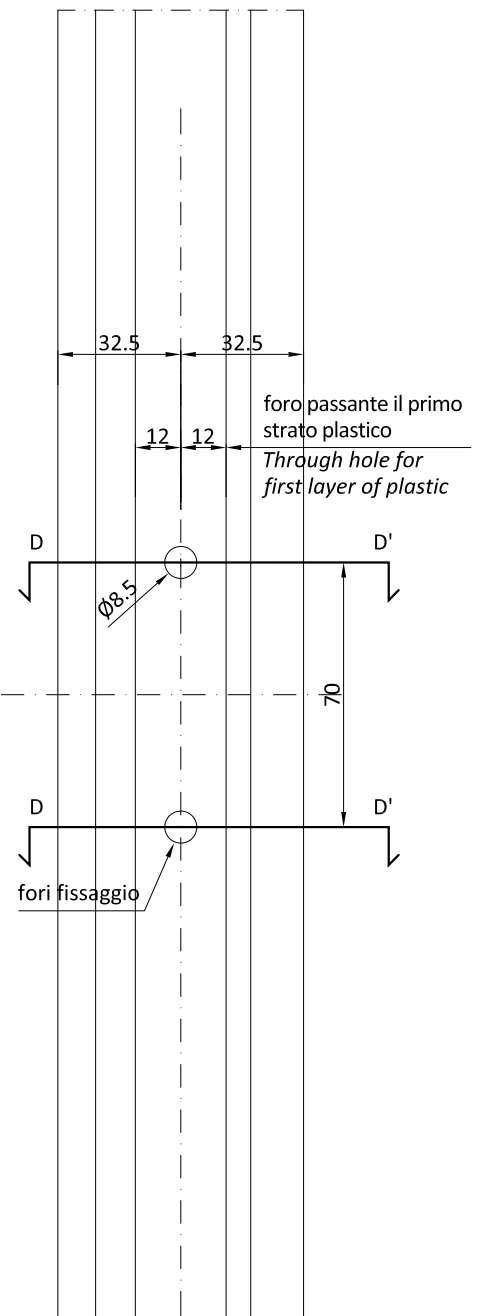
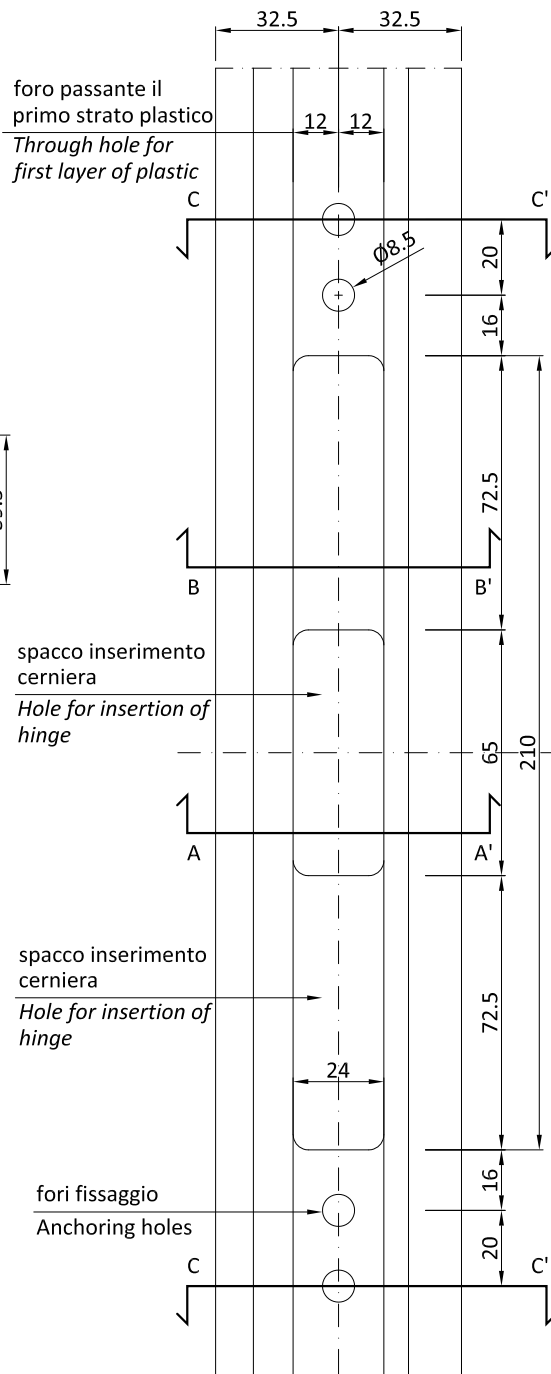
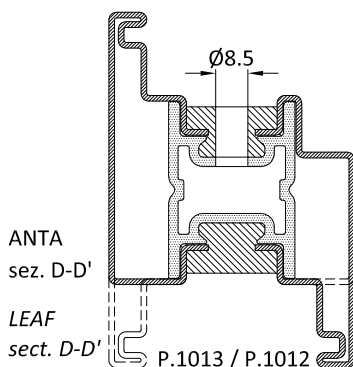
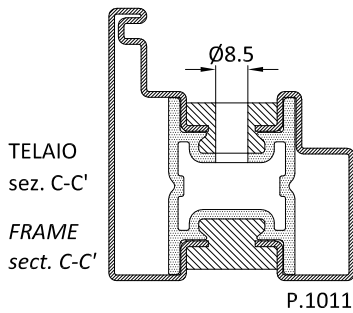
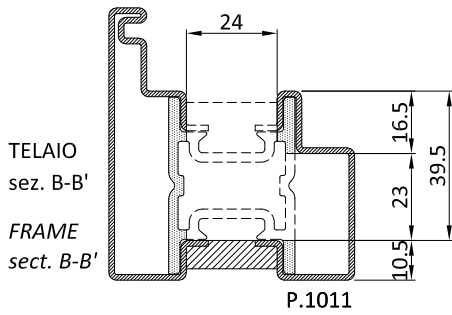
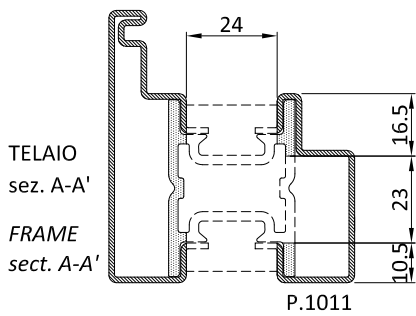



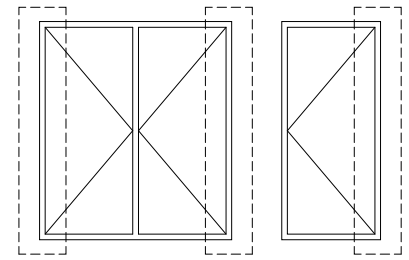
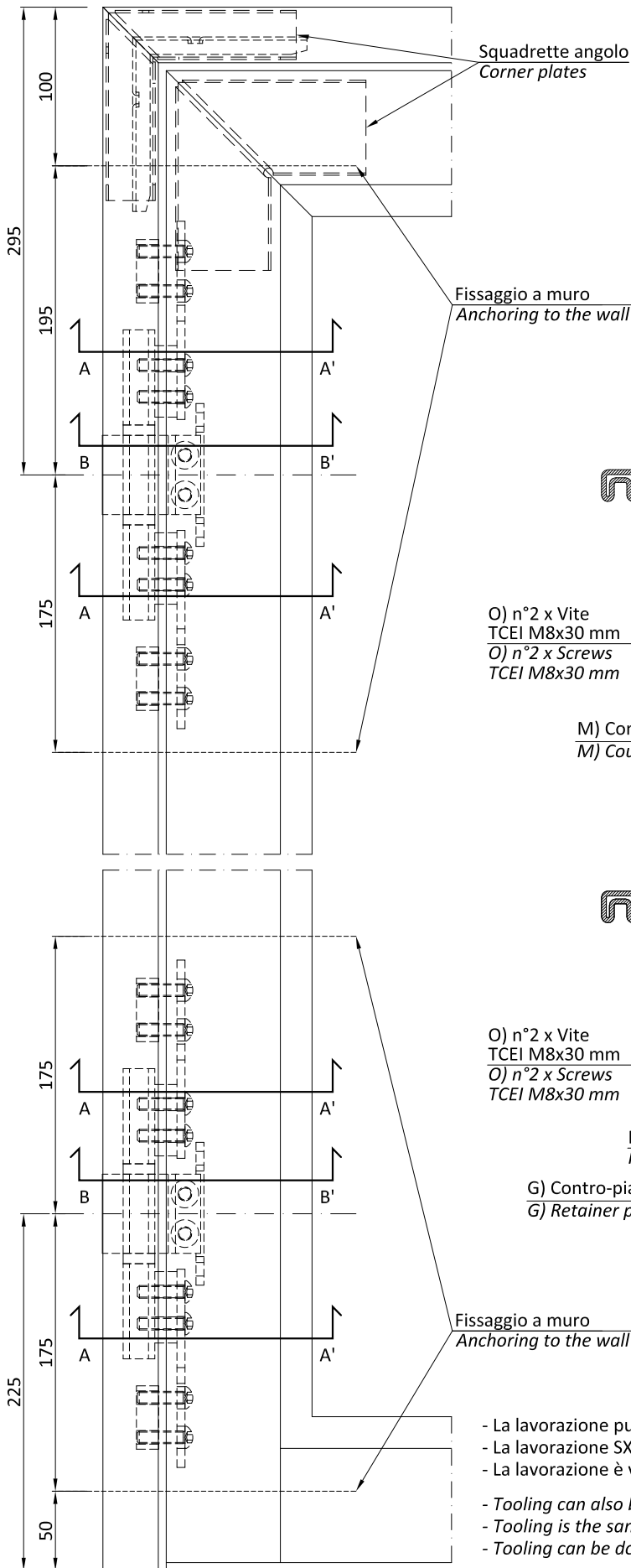

Peso max. per anta 180 kg  
Massima apertura 96°  
Max. weight for leaf: 180 kg  
Maximum opening 96°

Lavorazione eseguibile con fresa AT1058  
Tooling possible with milling cutter AT1058

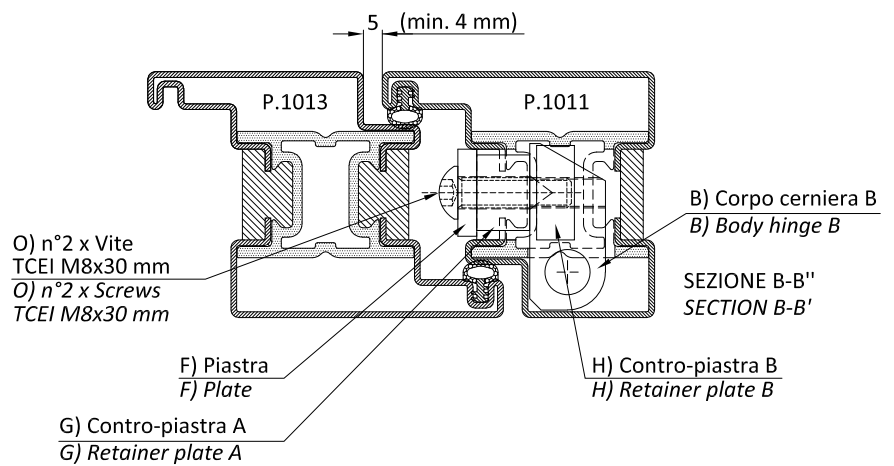
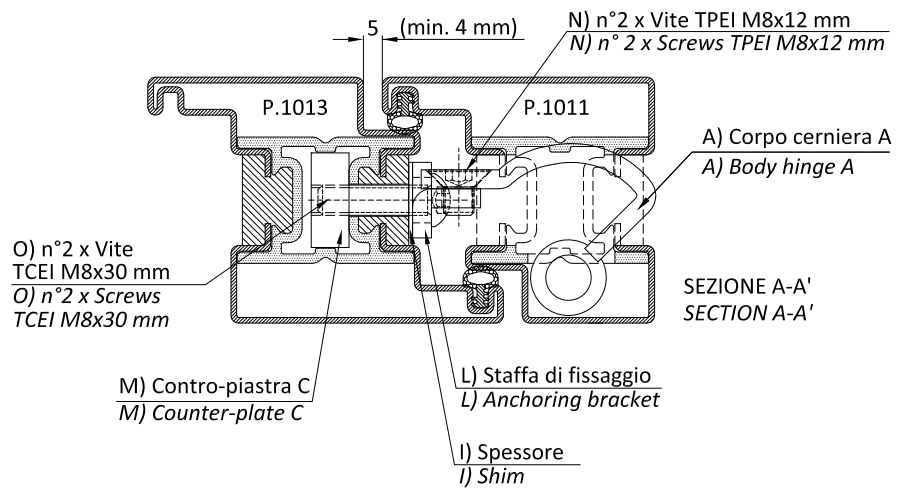

- La lavorazione può essere effettuata anche in posizioni intermedie dell'altezza della porta.
- La lavorazione SX è speculare alla DX.
- La lavorazione è valida anche per le aperture esterne.
- Tooling can also be carried out in intermediate positions.
- Tooling is the same on the right and on the left.
- Tooling can be done also on external openings.

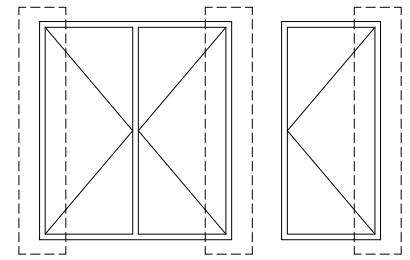
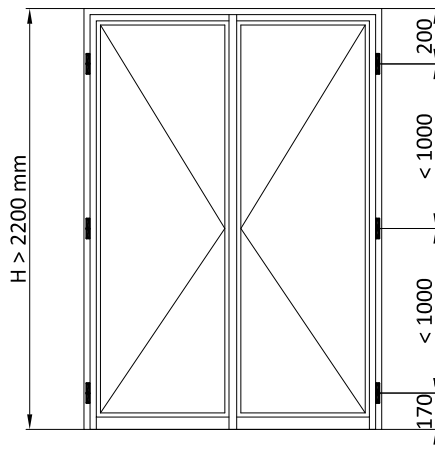
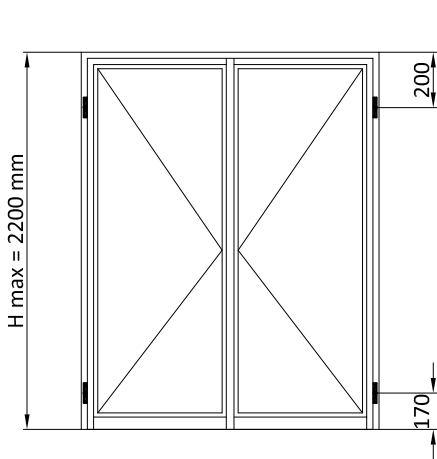

Peso max. per anta 200 kg  
Max. weight for leaf: 200 kg

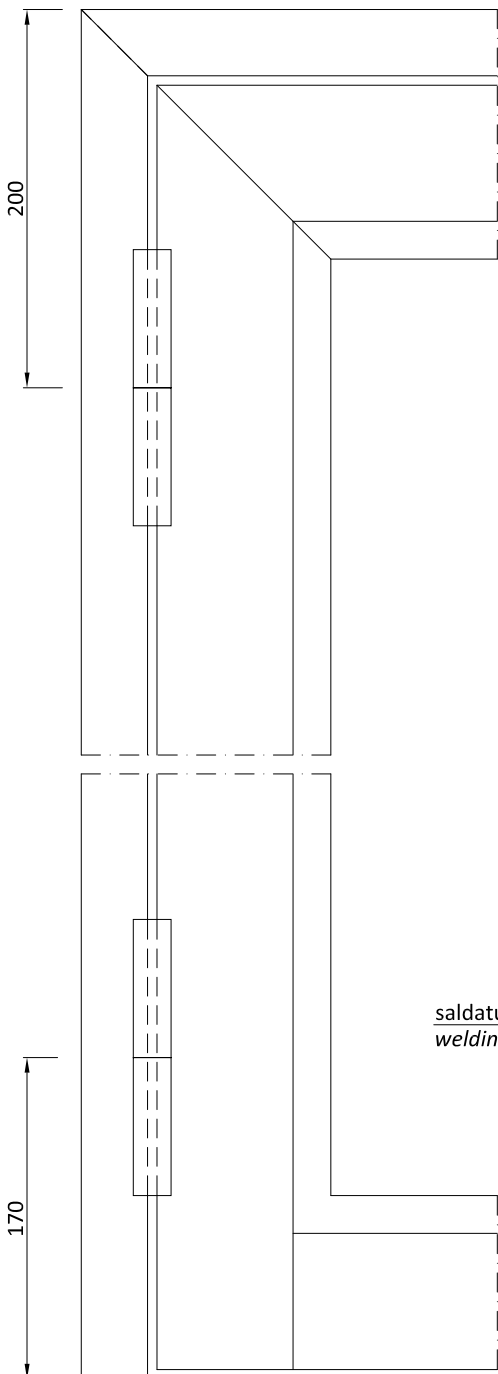

Posizionare le cerniere come da disegno saldandole sui alti.  
Position the hinges as in the drawing, welding them on the sides.

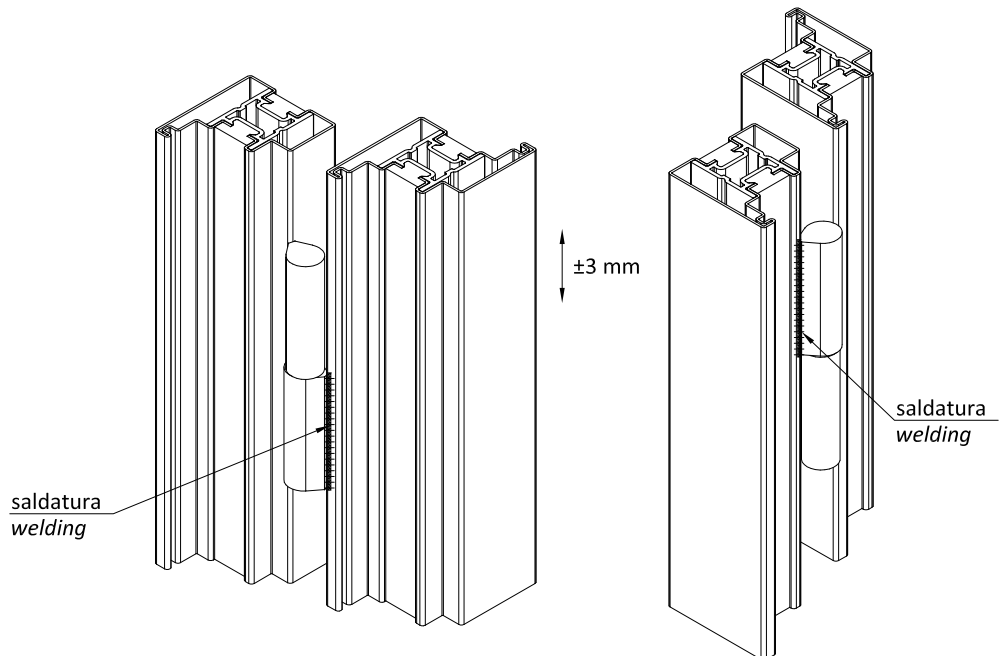
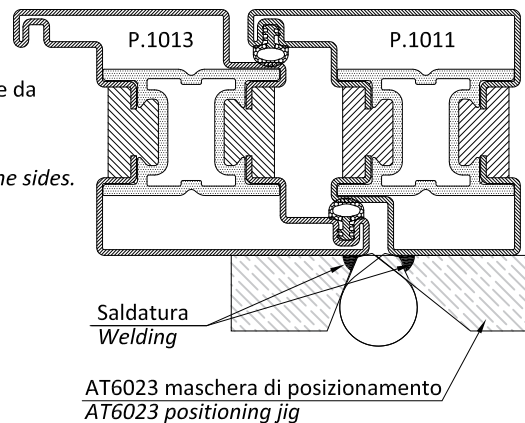

- La lavorazione può essere effettuata anche in posizioni intermedie dell'altezza della porta.
- La lavorazione SX è speculare alla DX.
- La lavorazione è valida anche per le aperture esterne.
- Tooling can be carried out also in intermediate positions regarding the height of the door.
- Tooling on left is the same as that on the right.
- Tooling can be done also on external openings.

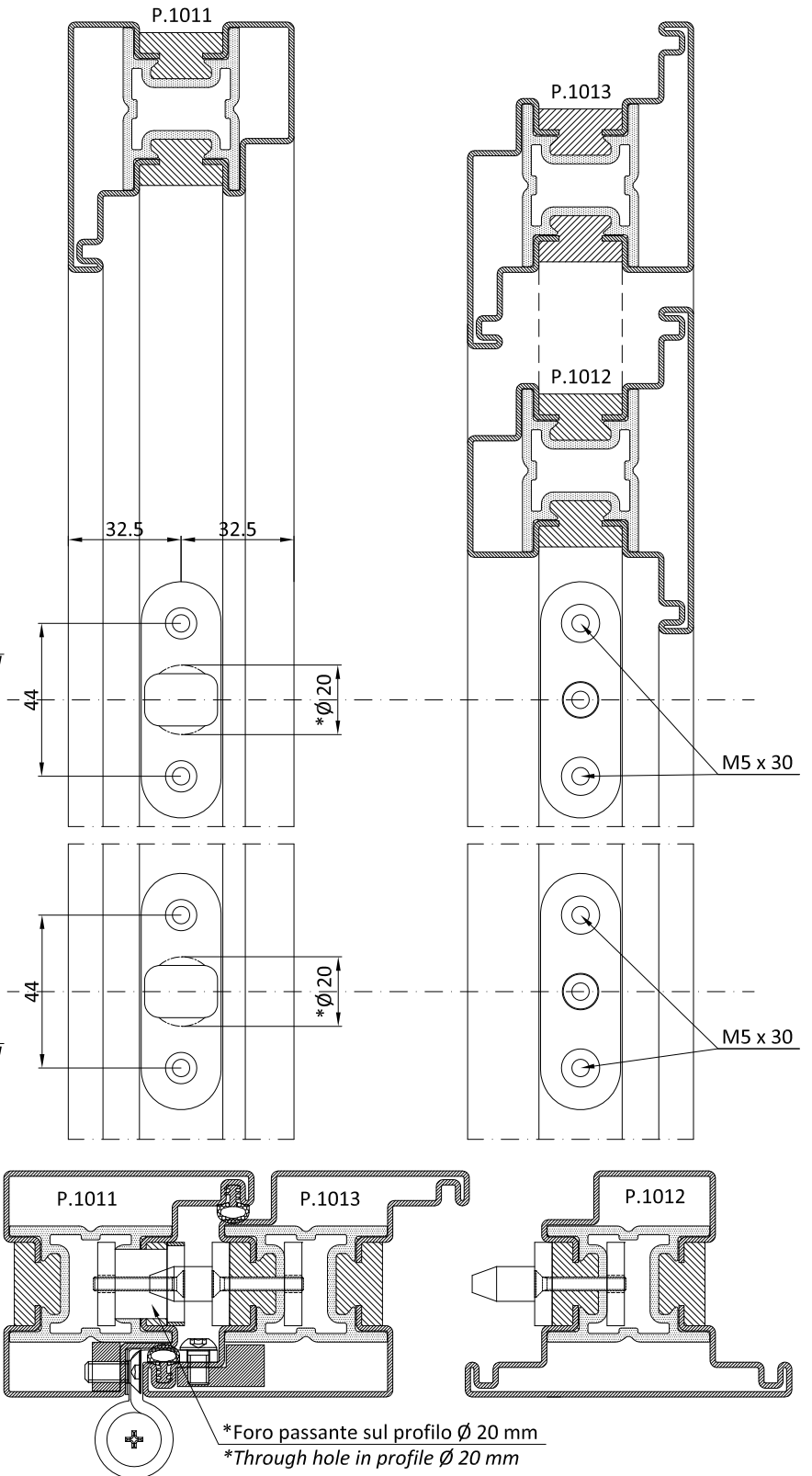
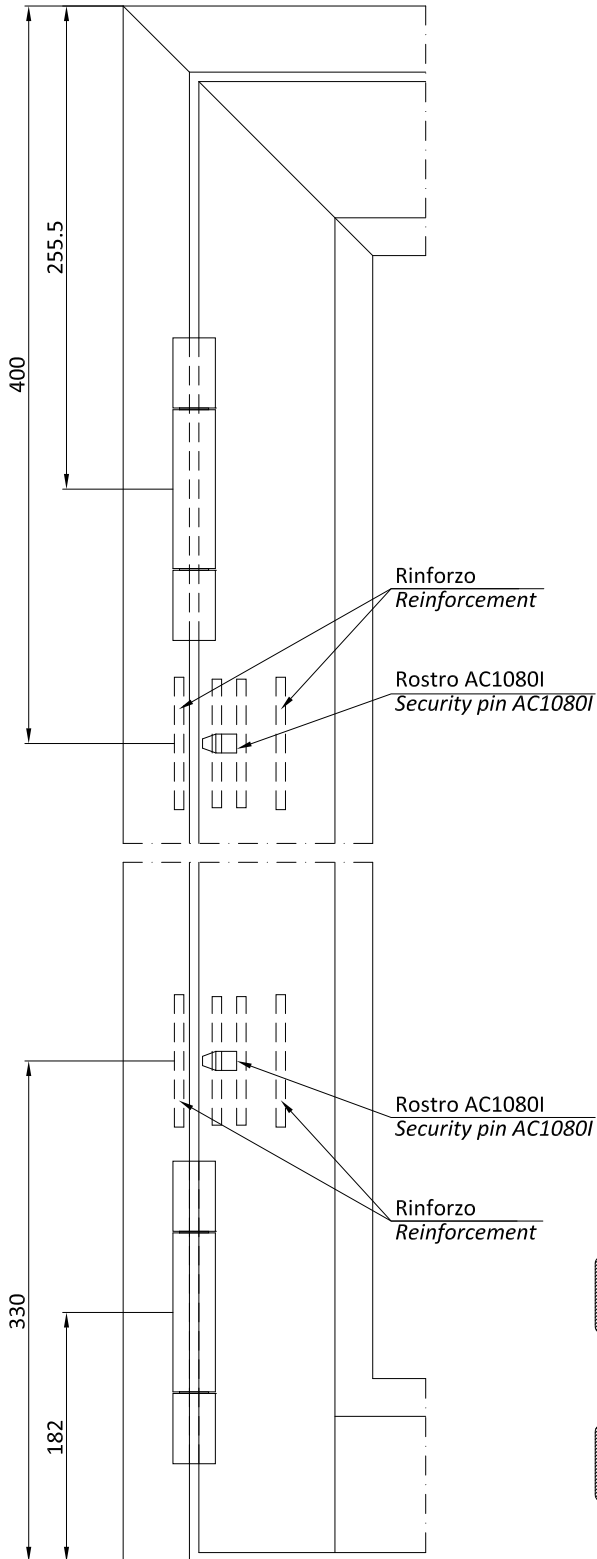
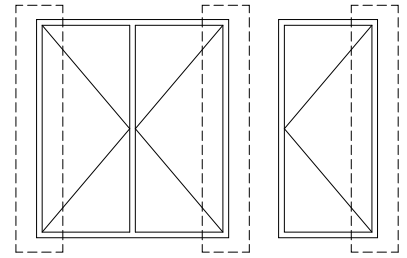
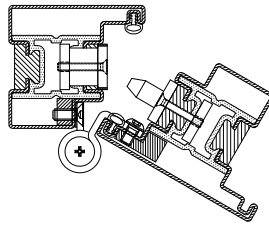
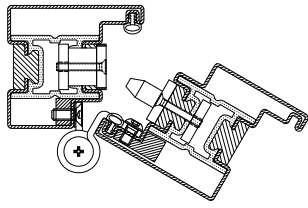

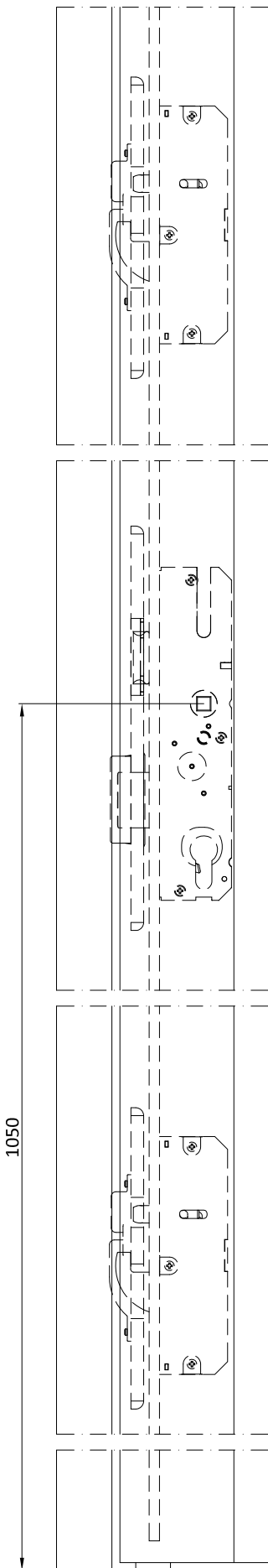

AC1065WD/S \_ AC1066WD/S

- 1) Serratura
- 2) Frontalino
- 3) Scrocco
- 4) Catenaccio
- 5) Incontro per serratura
- 6) Deviatori (n°2 pezzi sup + inf.)
- 7) Catenaccio (n°2 pezzi sup + inf.)
- 8) Incontro (n°2 pezzi sup + inf.)

AC1065WD/S \_ AC1066WD/S

- 1) Lock
- 2) Front plate
- 3) Spring latch
- 4) Bolt
- 5) Strike plate
- 6) Diverters (n° 2 items upper + lower)
- 7) Bolt (n° 2 items upper + lower)
- 8) Plate (no. 2 items upper + lower)

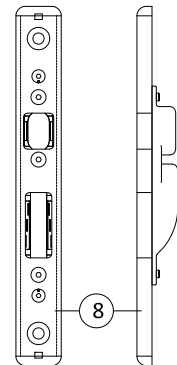
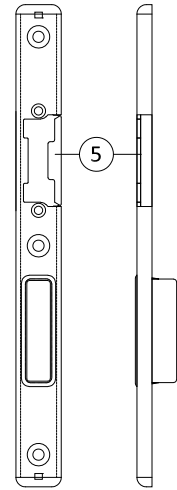
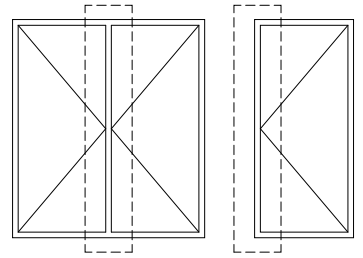
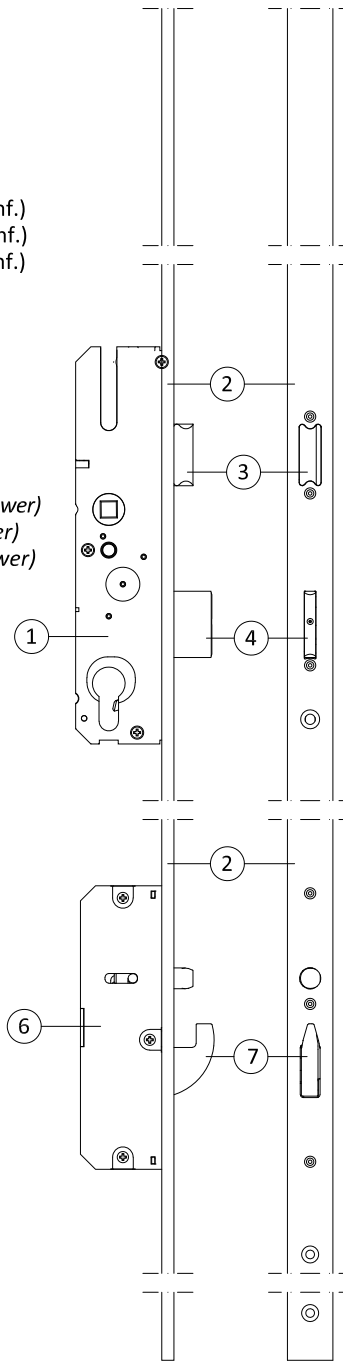

SCHEMA UTILIZZO SERRATURE  
DIAGRAM FOR THE USE OF LOCKS

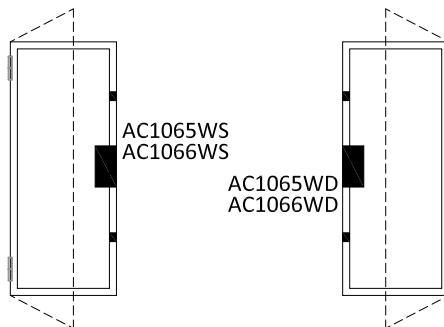

APERTURA INTERNA \_ VISTA INTERNA  
INWARDS OPENING \_ INTERIOR ELEVATION

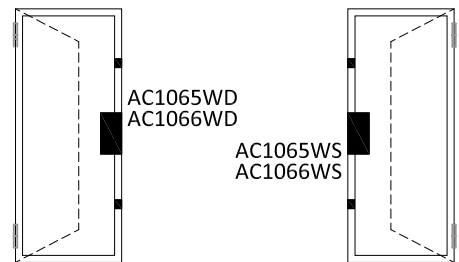

APERTURA ESTERNA \_ VISTA INTERNA  
OUTWARDS OPENING \_ INTERIOR ELEVATION

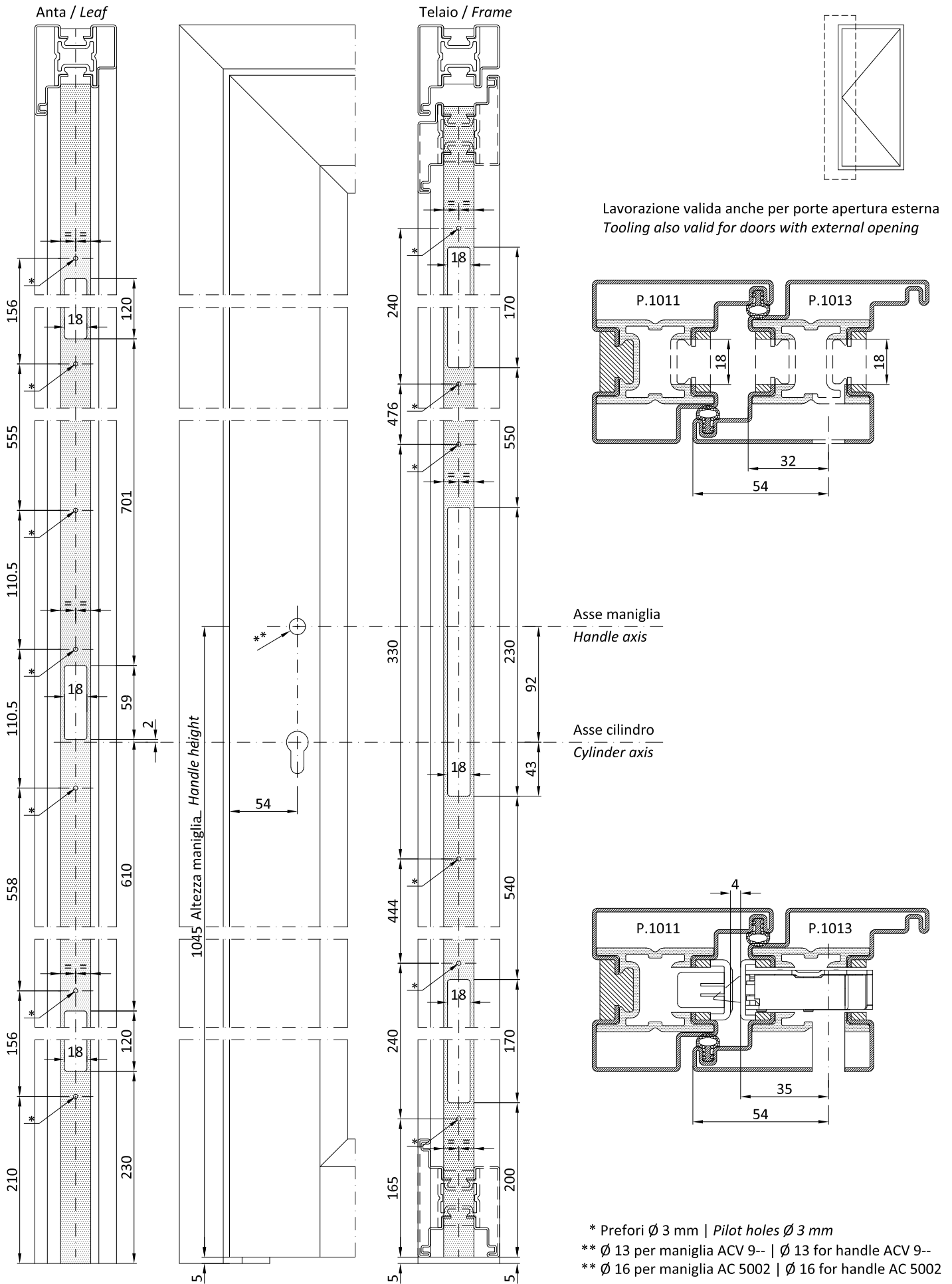



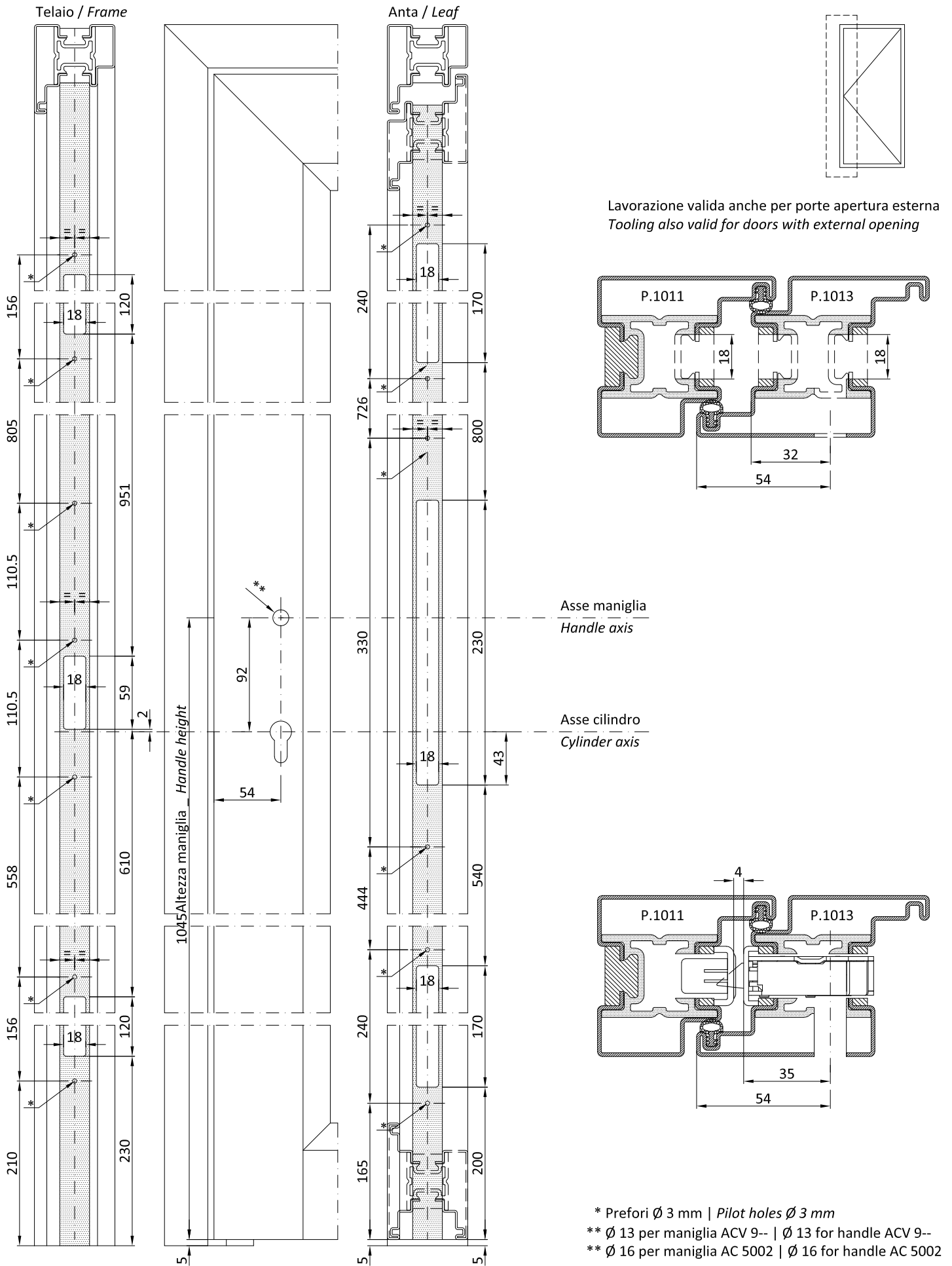

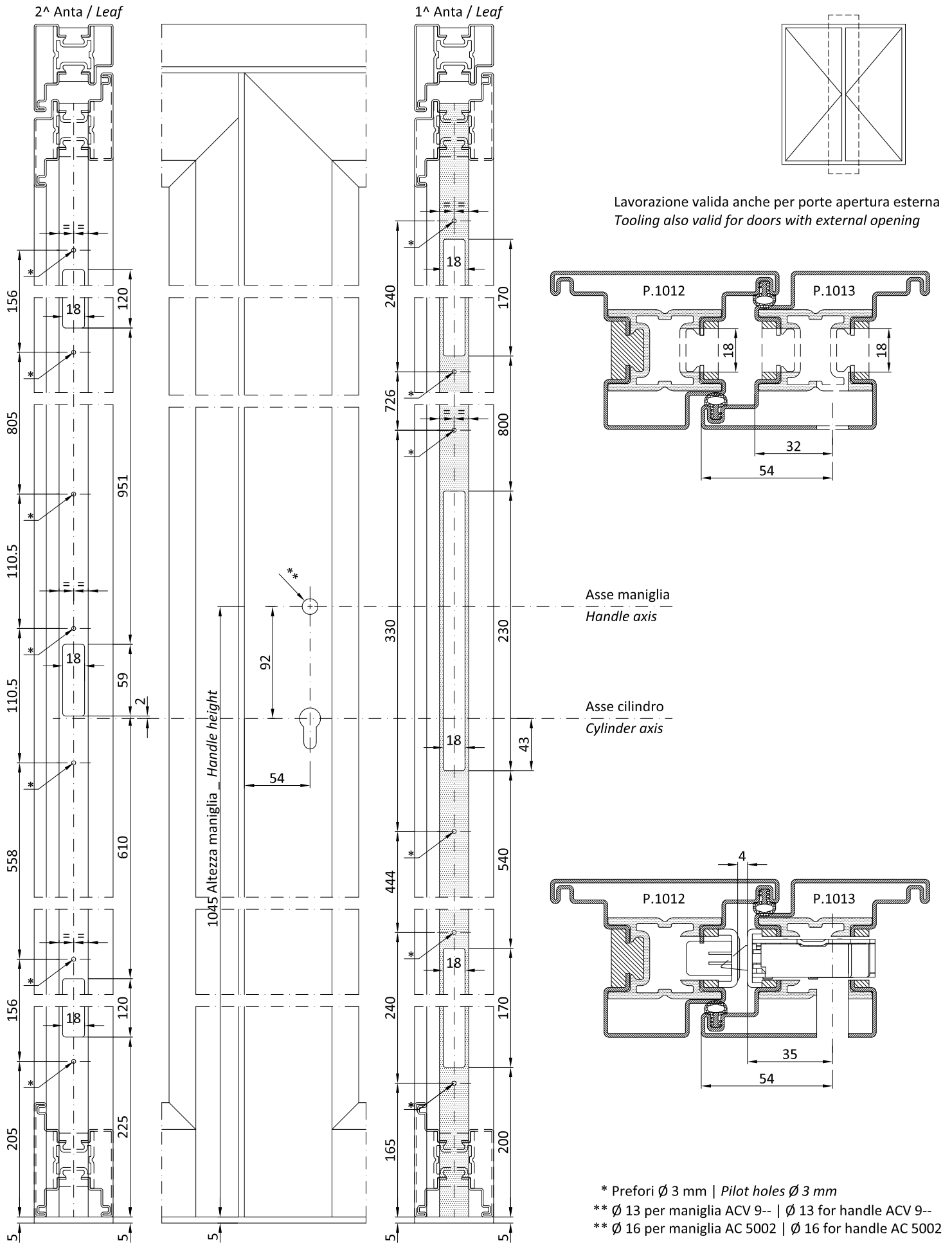

Lavorazione valida anche per porte apertura esterna  
Tooling also valid for doors with external opening

Asse maniglia  
Handle axis

Asse cilindro  
Cylinder axis

\* Prefori Ø 3 mm | Pilot holes Ø 3 mm  
\*\* Ø 13 per maniglia ACV 9-- | Ø 13 for handle ACV 9--  
\*\* Ø 16 per maniglia AC 5002 | Ø 16 for handle AC 5002



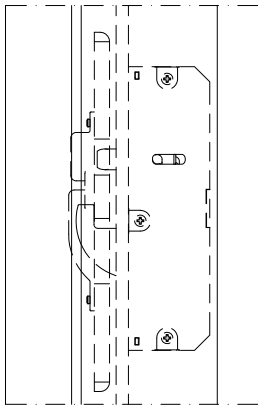

AC1067WD/S

- 1) Serratura
- 2) Frontalino
- 3) Scrocco
- 4) Catenaccio
- 5) Incontro per serratura
- 6) Deviatori (n°3 pezzi sup + inf.)
- 7) Catenaccio (n°3 pezzi sup + inf.)
- 8) Incontro (n°3 pezzi sup + inf.)

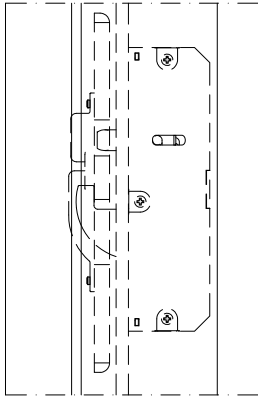
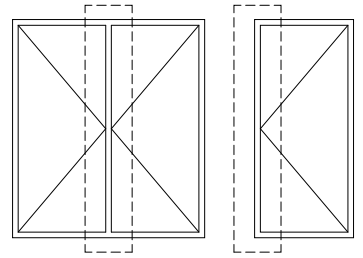

AC1067WD/S

- 1) Lock
- 2) Front plate
- 3) Spring latch
- 4) Bolt
- 5) Strike plate
- 6) Diverters (n° 3 items upper + lower)
- 7) Bolt (n° 3 items upper + lower)
- 8) Plate (no. 3 items upper + lower)

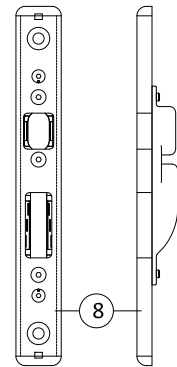
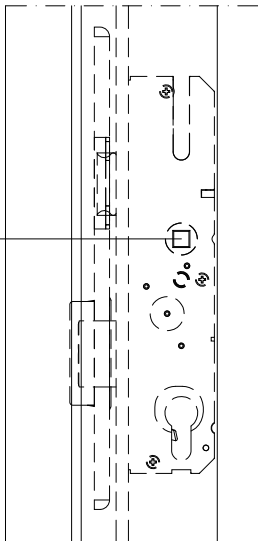
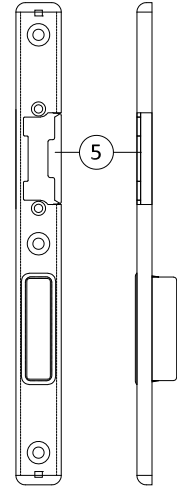
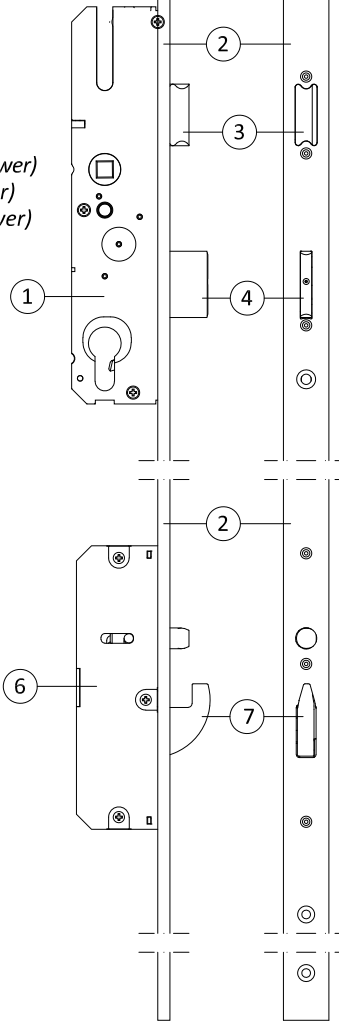

1050

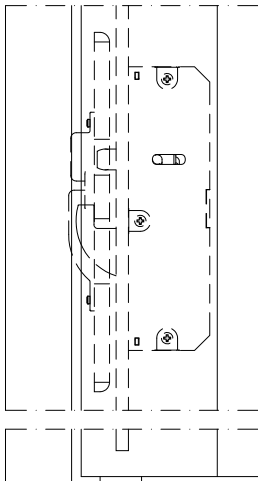

SCHEMA UTILIZZO SERRATURE  
DIAGRAM FOR THE USE OF LOCKS

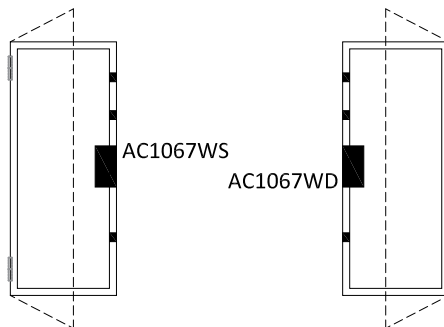

AC1067WS  
AC1067WD  
APERTURA INTERNA \_ VISTA INTERNA  
INWARDS OPENING \_ INTERIOR ELEVATION

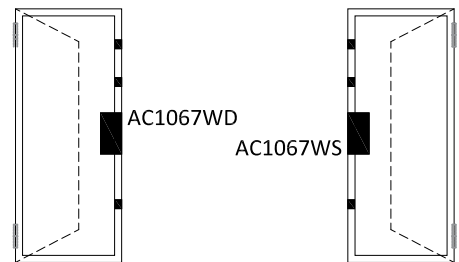

AC1067WD  
AC1067WS  
APERTURA ESTERNA \_ VISTA INTERNA  
OUTWARDS OPENING \_ INTERIOR ELEVATION

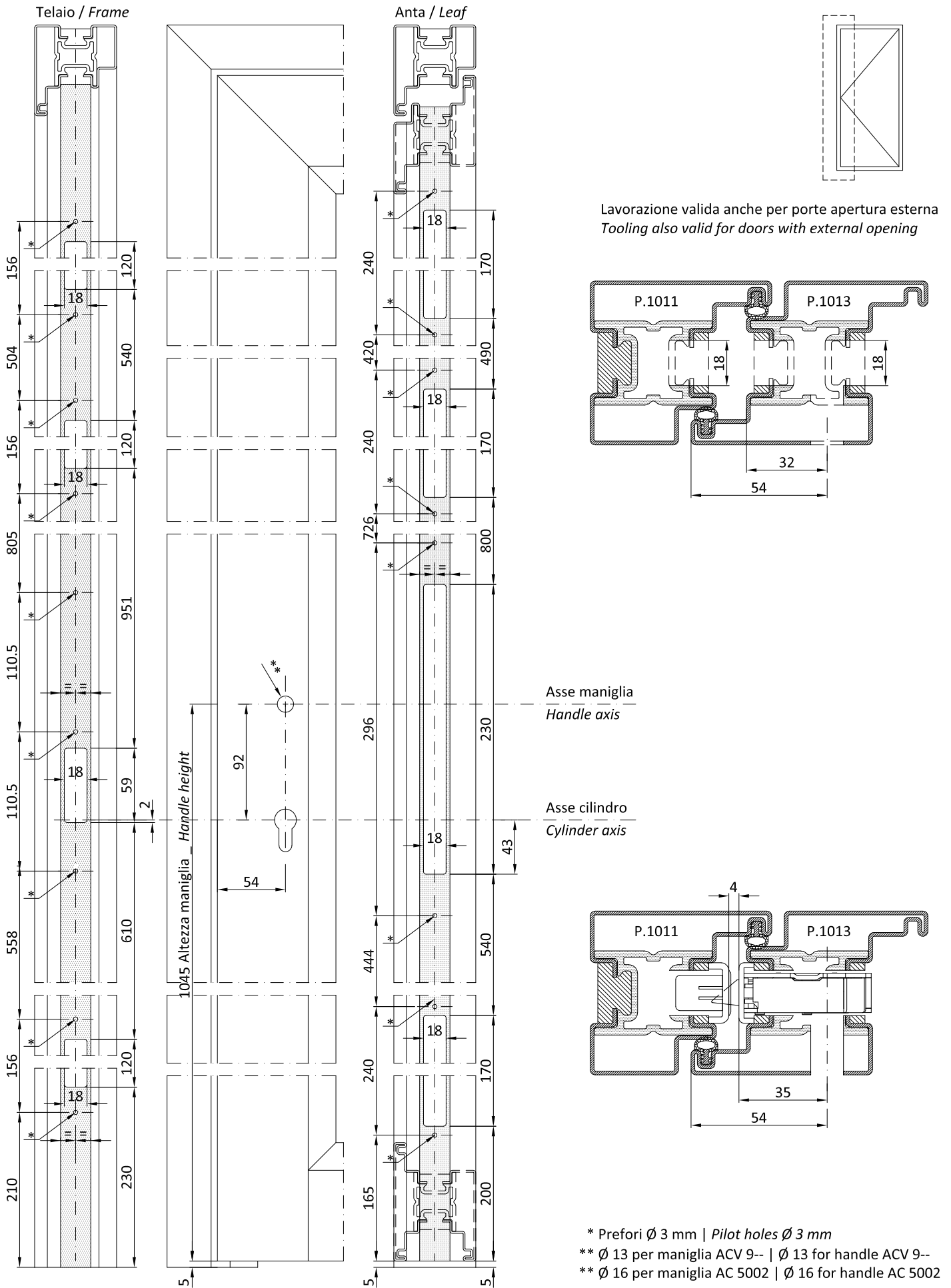



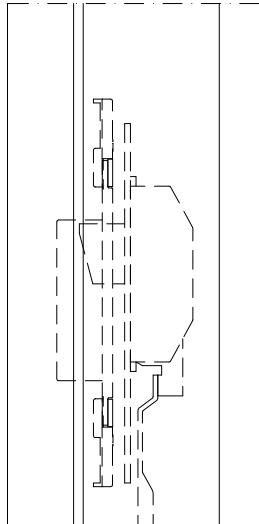

AC1070

- 1) Serratura
- 2) Frontalino
- 3) Riduttore di collegamento
- 4) Scrocco
- 5) Catenaccio
- 6) Incontro per serratura
- 7) Vite inox TS M5x50
- 8) Perno fissaggio asta

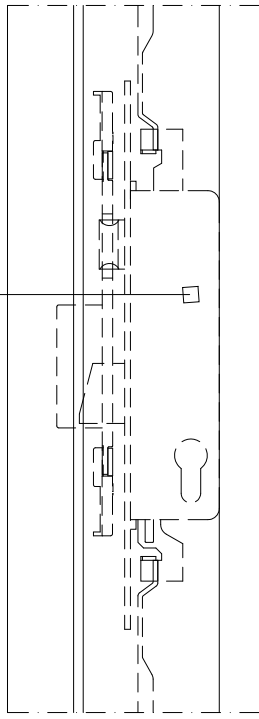
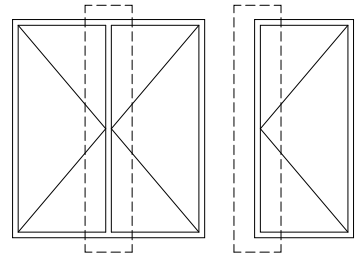

AC1075

- 9) Deviatori (n°2 pezzi sup + inf.)
- 10) Frontalino (n°2 pezzi sup + inf.)
- 11) Catenaccio (n°2 pezzi sup + inf.)
- 12) Aste inox (n°2 pezzi sup + inf.)
- 13) Incontro (n°2 pezzi sup + inf.)

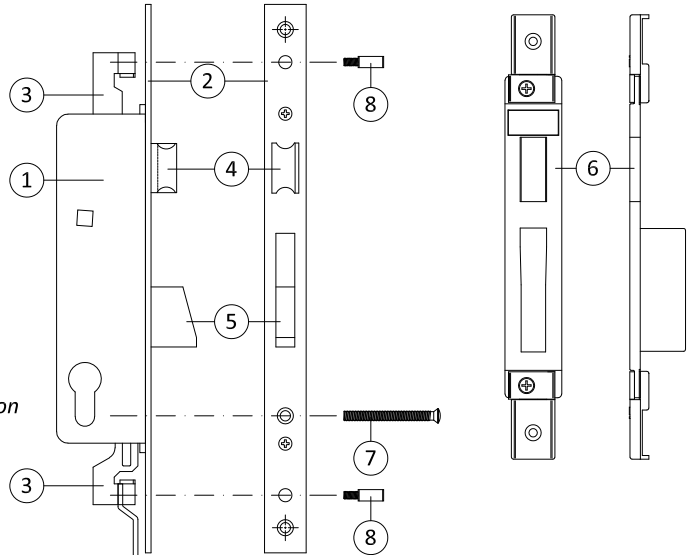

AC1070

- 1) Lock
- 2) Front plate
- 3) Reduction unit/adapter for connection
- 4) Spring latch
- 5) Bolt
- 6) Strike plate
- 7) Stainless steel screws TS M5x50
- 8) Pin for anchoring the rod

AC1075

- 9) Diverters (n° 2 items upper + lower)
- 10) Apron lining (n° 2 items upper + lower)
- 11) Bolt (n° 2 items upper + lower)
- 12) Stainless steel rods (n° 2 items upper + lower)
- 13) Plate (n° 2 items upper + lower)

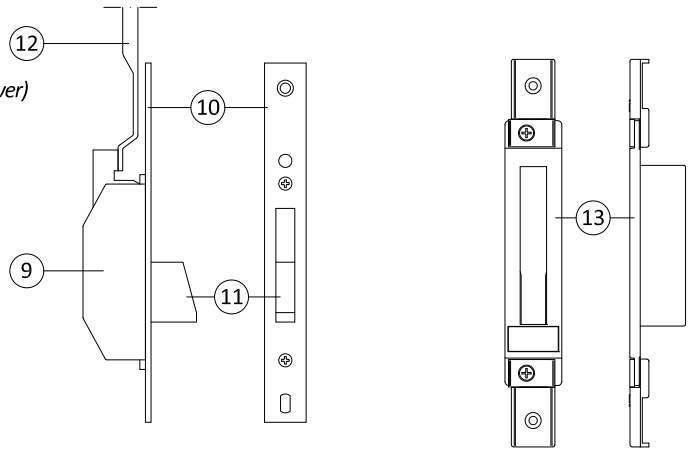

1050

SCHEMA UTILIZZO SERRATURE E TERZE CHIUSURE  
DIAGRAM FOR THE USE OF LOCKS AND THIRD LOCKS

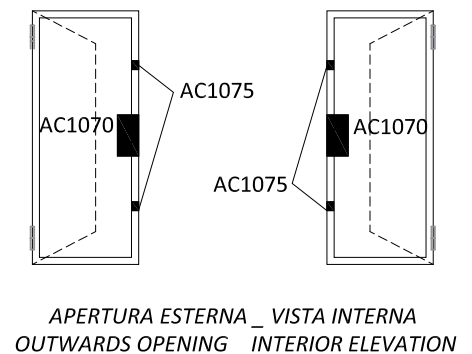
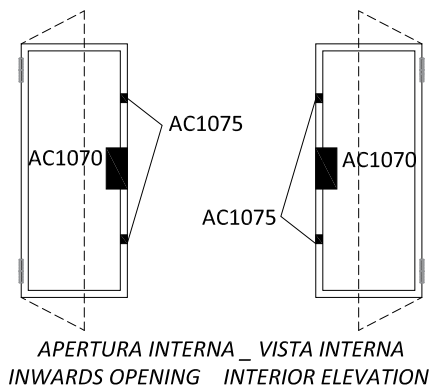

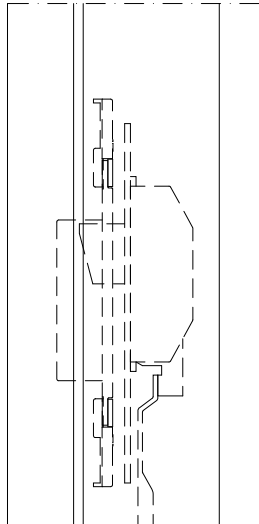

**AC1071**

- 1) Serratura
- 2) Frontalino
- 3) Riduttore di collegamento
- 4) Rullo
- 5) Catenaccio
- 6) Incontro per serratura
- 7) Vaschetta per rullo
- 8) Vite inox TS M5x50
- 9) Perno fissaggio asta

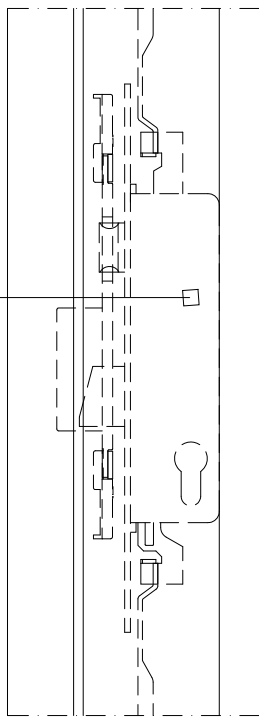
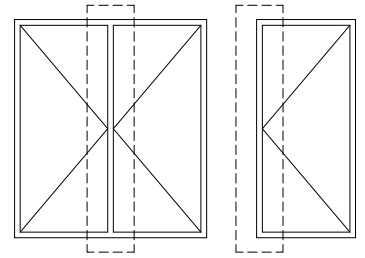

**AC1075**

- 10) Deviatori (n°2 pezzi sup + inf.)
- 11) Frontalino (n°2 pezzi sup + inf.)
- 12) Catenaccio (n°2 pezzi sup + inf.)
- 13) Aste inox (n°2 pezzi sup + inf.)
- 14) Incontro (n°2 pezzi sup + inf.)

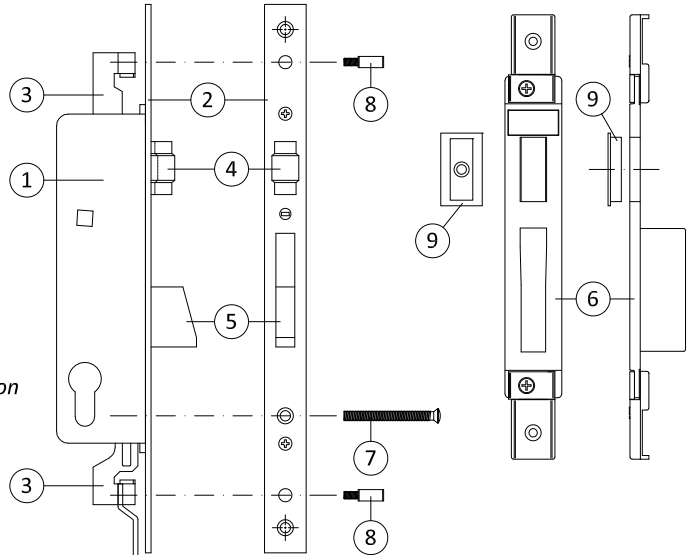

**AC1071**

- 1) Lock
- 2) Front plate
- 3) Reduction unit/adaptor for connection
- 4) Roller
- 5) Bolt
- 6) Strike plate
- 7) Compartment for roller
- 8) Stainless steel screws TS M5x50
- 9) Pin for anchoring the rod

**AC1075**

- 10) Diverters (n° 2 items upper + lower)
- 11) Apron lining (n° 2 items upper + lower)
- 11) Bolt (n° 2 items upper + lower)
- 13) Stainless steel rods (n° 2 items upper + lower)
- 14) Plate (n° 2 items upper + lower)

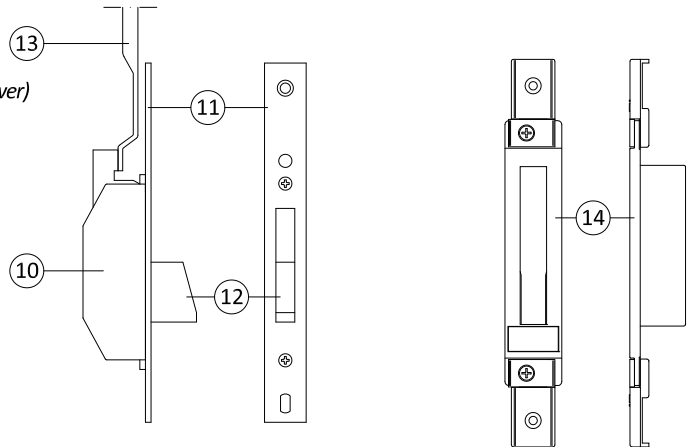

1050

**SCHEMA UTILIZZO SERRATURE E TERZE CHIUSURE  
DIAGRAM FOR THE USE OF LOCKS AND THIRD LOCKS**

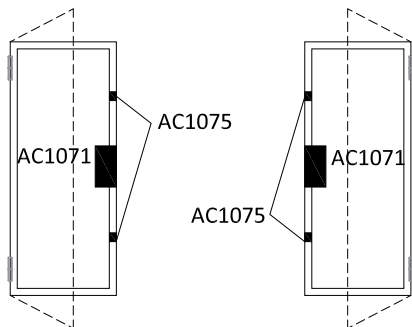

**APERTURA INTERNA \_ VISTA INTERNA  
INWARDS OPENING \_ INTERIOR ELEVATION**

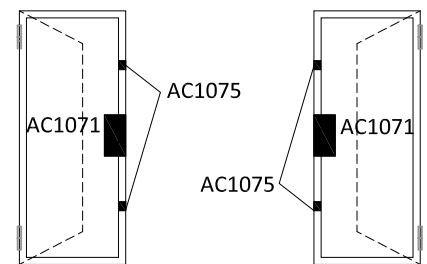

**APERTURA ESTERNA \_ VISTA INTERNA  
OUTWARDS OPENING \_ INTERIOR ELEVATION**



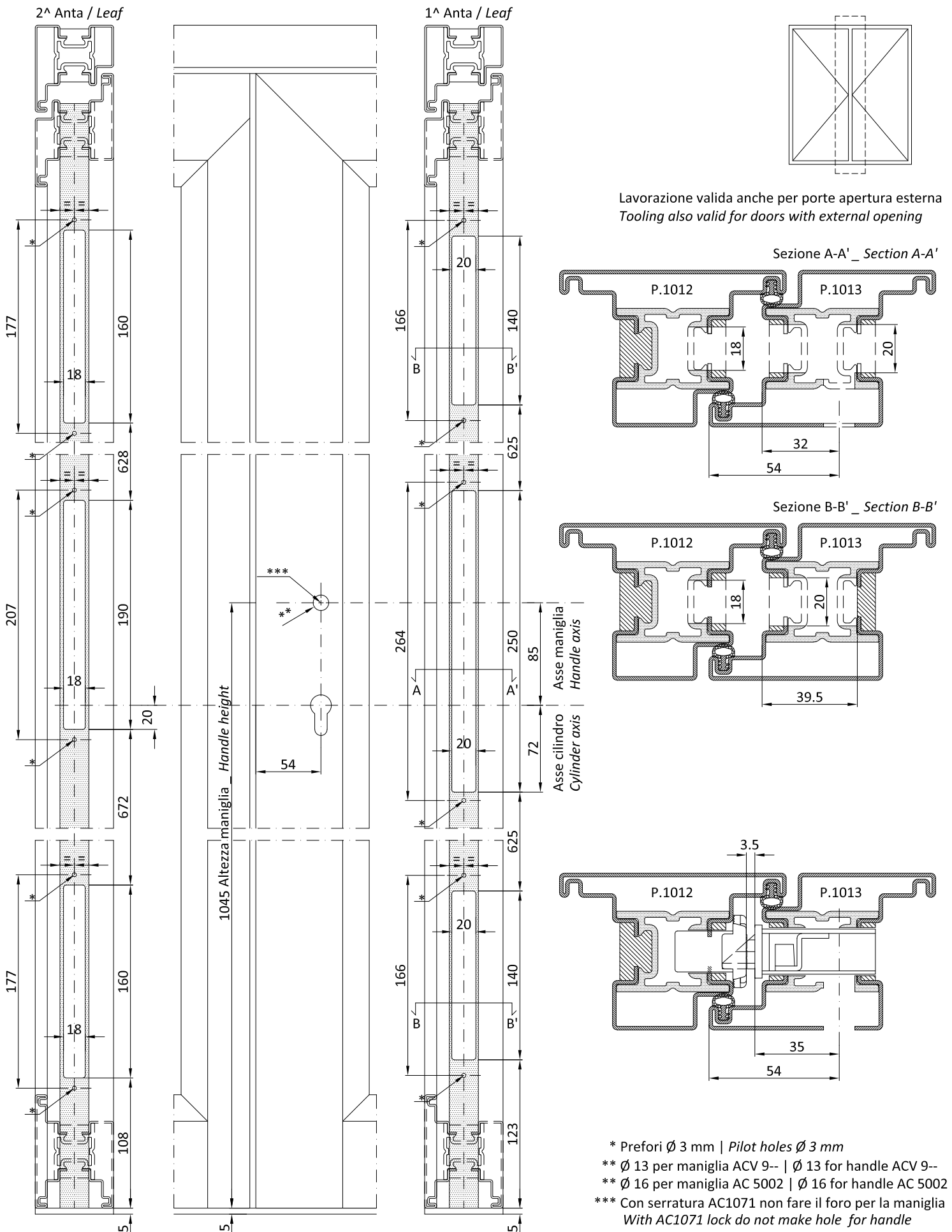

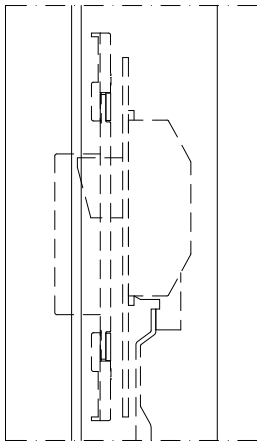

**AC1072**

- 1) Serratura
- 2) Frontalino
- 3) Riduttore di collegamento
- 4) Scrocco
- 5) Catenaccio
- 6) Incontro per serratura
- 7) Vite inox TS M5x50
- 8) Perno fissaggio asta

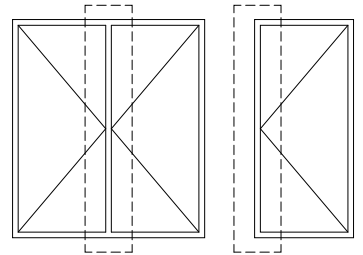

**AC1075**

- 9) Deviatori (n°2 pezzi sup + inf.)
- 10) Frontalino (n°2 pezzi sup + inf.)
- 11) Catenaccio (n°2 pezzi sup + inf.)
- 12) Aste inox (n°2 pezzi sup + inf.)
- 13) Incontro (n°2 pezzi sup + inf.)

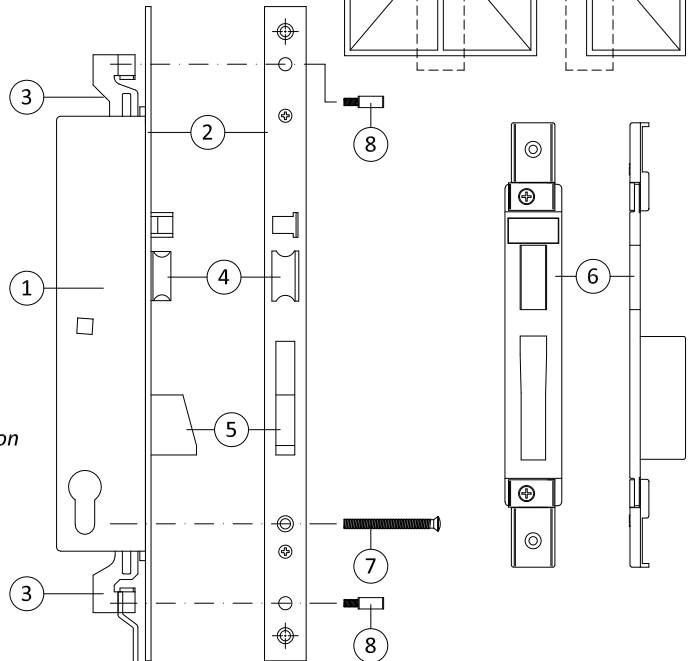

**AC1072**

- 1) Lock
- 2) Front plate
- 3) Reduction unit/adaptor for connection
- 4) Spring latch
- 5) Bolt
- 6) Strike plate
- 7) Stainless steel screws TS M5x50
- 8) Pin for anchoring the rod

**AC1075**

- 9) Diverters (n° 2 items upper + lower)
- 10) Apron lining (n° 2 items upper + lower)
- 11) Bolt (n° 2 items upper + lower)
- 12) Stainless steel rods (n° 2 items upper + lower)
- 13) Plate (n° 2 items upper + lower)

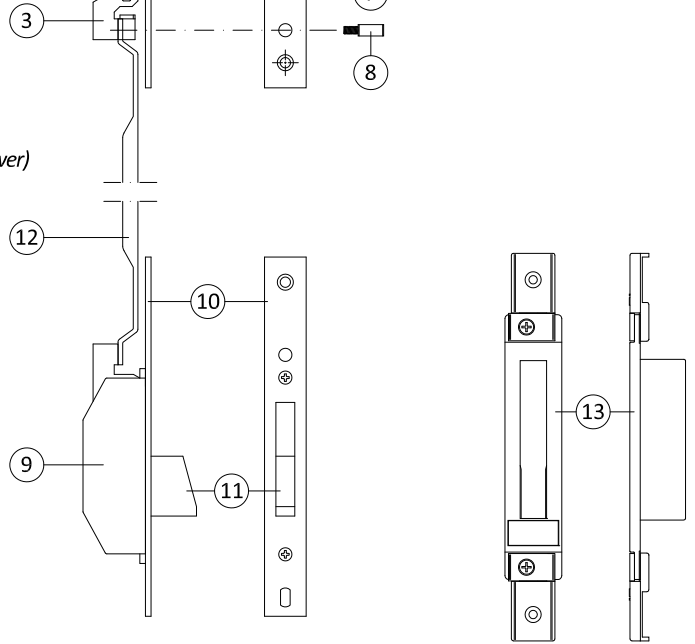

1050

**SCHEMA UTILIZZO SERRATURE E TERZE CHIUSURE  
DIAGRAM FOR THE USE OF LOCKS AND THIRD LOCKS**

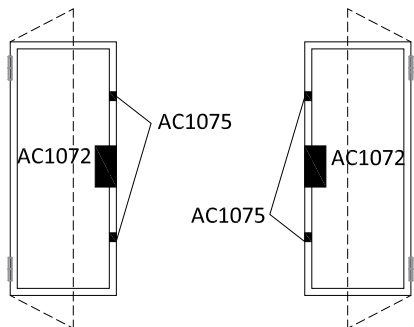

**APERTURA INTERNA \_ VISTA INTERNA  
INWARDS OPENING \_ INTERIOR ELEVATION**

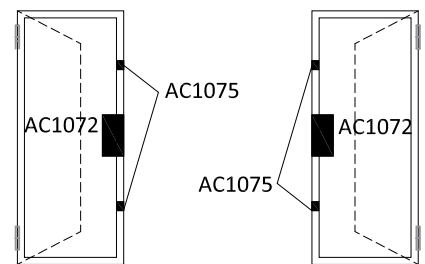

**APERTURA ESTERNA \_ VISTA INTERNA  
OUTWARDS OPENING \_ INTERIOR ELEVATION**





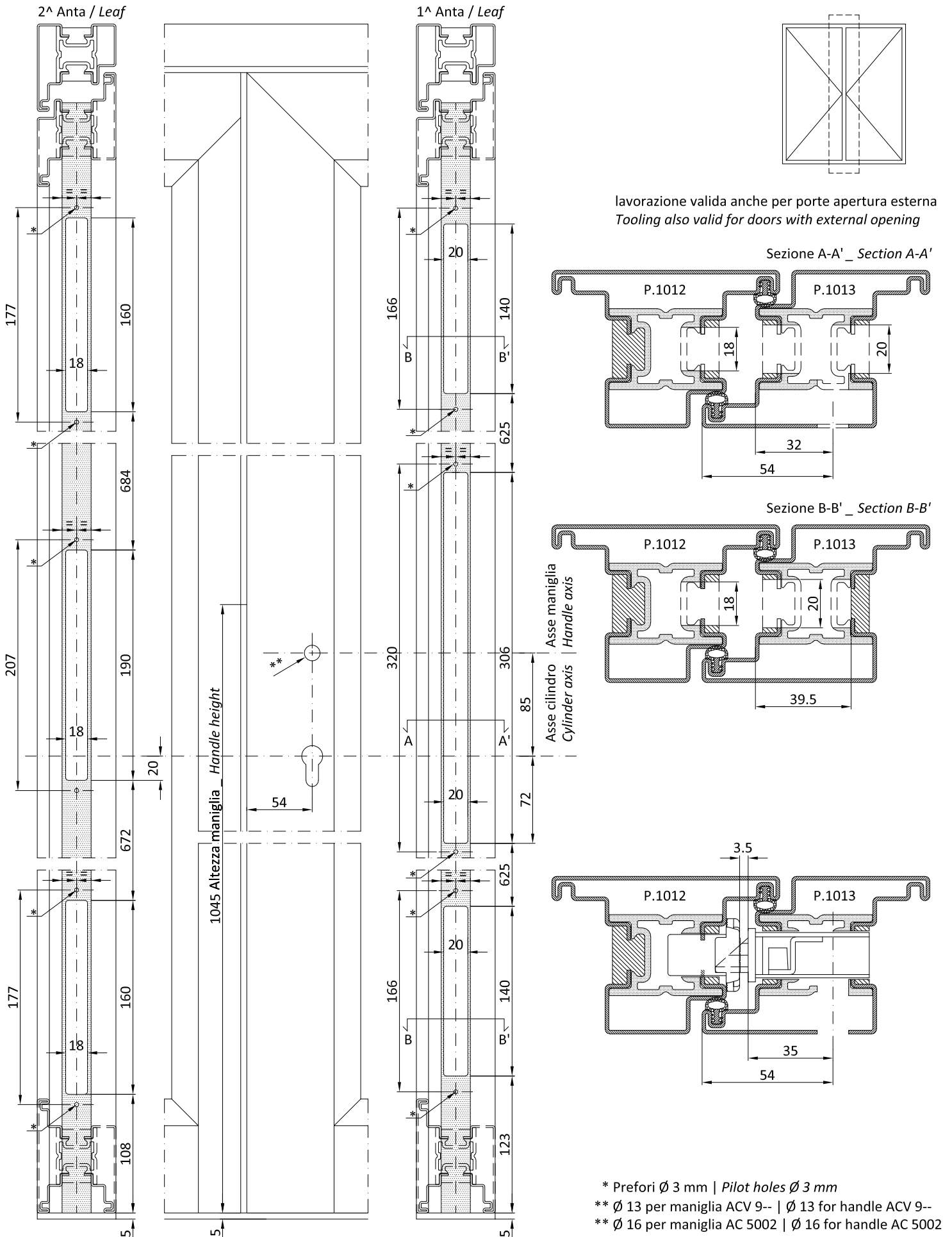

lavorazione valida anche per porte apertura esterna  
Tooling also valid for doors with external opening

\* Prefori Ø 3 mm | Pilot holes Ø 3 mm  
\*\* Ø 13 per maniglia ACV 9-- | Ø 13 for handle ACV 9--  
\*\* Ø 16 per maniglia AC 5002 | Ø 16 for handle AC 5002

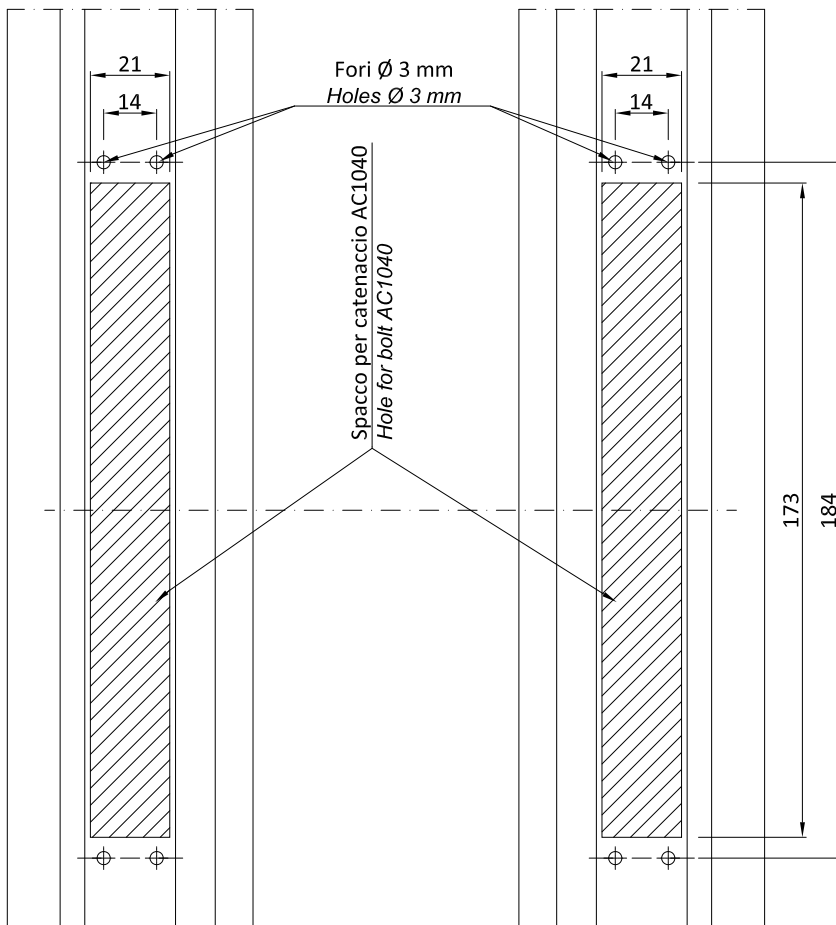
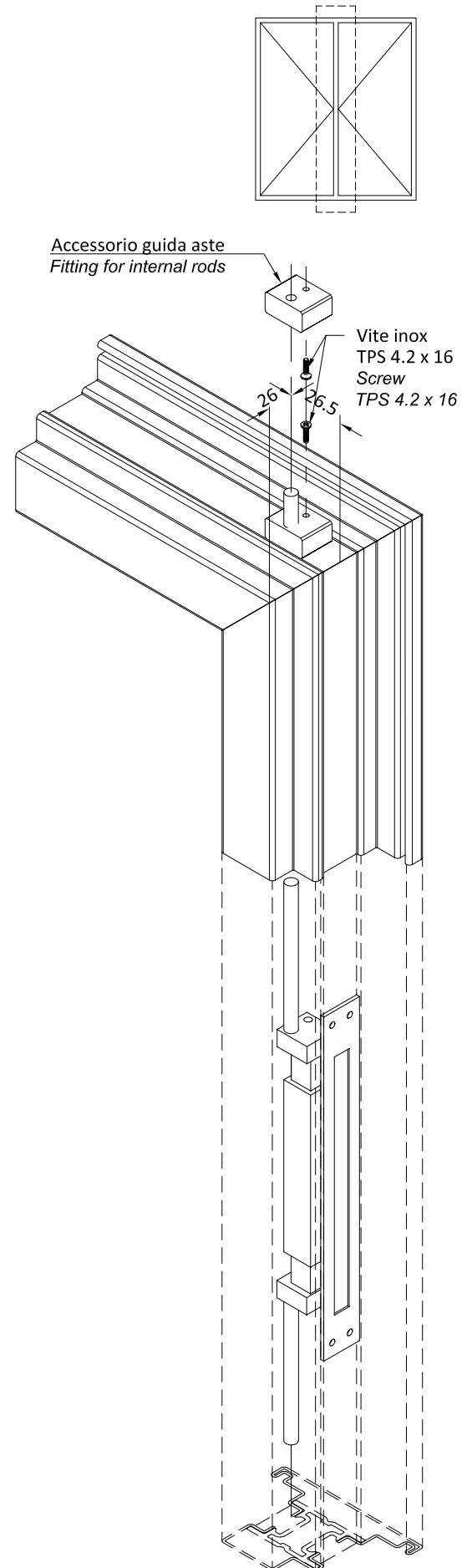
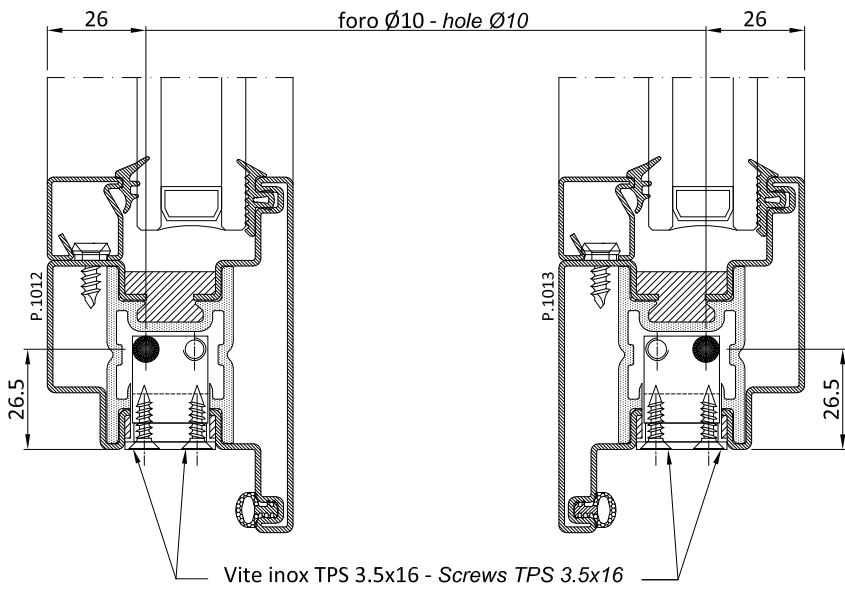

Aste  $\varnothing 7$  mm L mm 1500  
 $\varnothing 7$  mm L mm 1500 rods



AC1040 catenaccio  
AC1040 bolt

cod.	dimensioni dimensions [mm]
AC1081/A	615 → 730
AC1081/B	715 → 830
AC1081/C	815 → 930
AC1081/D	915 → 1030
AC1081/E	1015 → 1130
AC1081/F	1115 → 1230

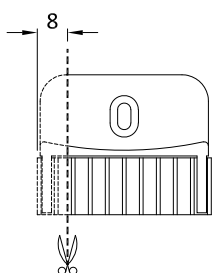
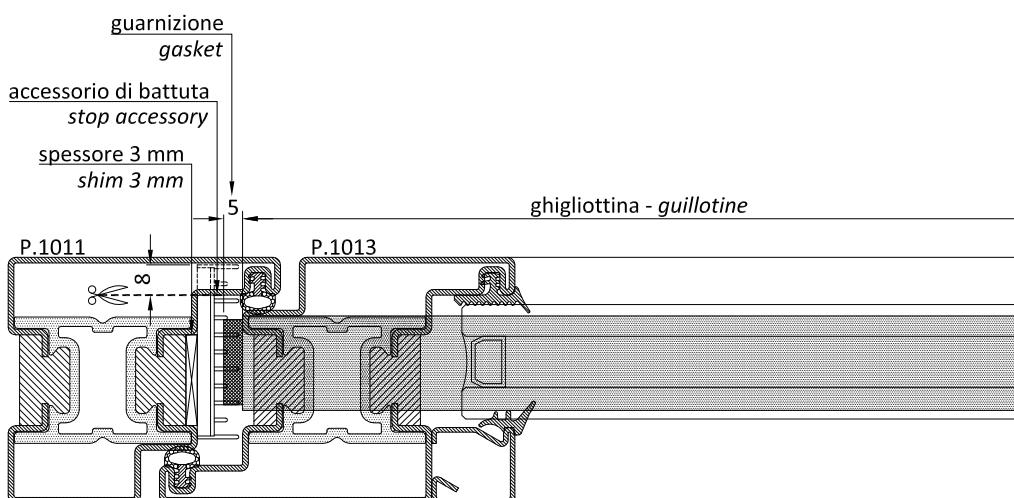
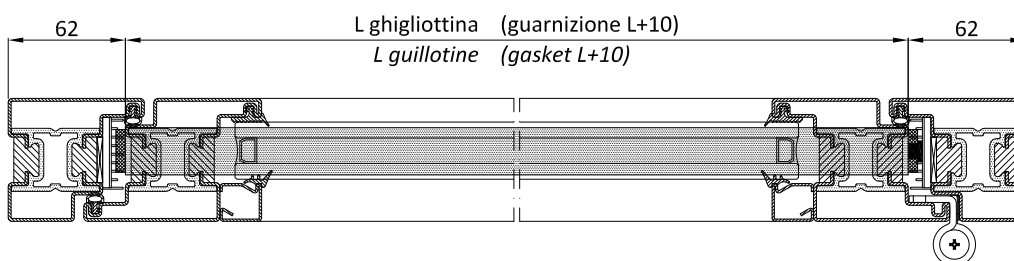
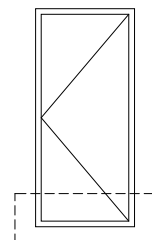

cod.	dimensioni dimensions [mm]
AC1081/A	615 → 730
AC1081/B	715 → 830
AC1081/C	815 → 930
AC1081/D	915 → 1030
AC1081/E	1015 → 1130
AC1081/F	1115 → 1230

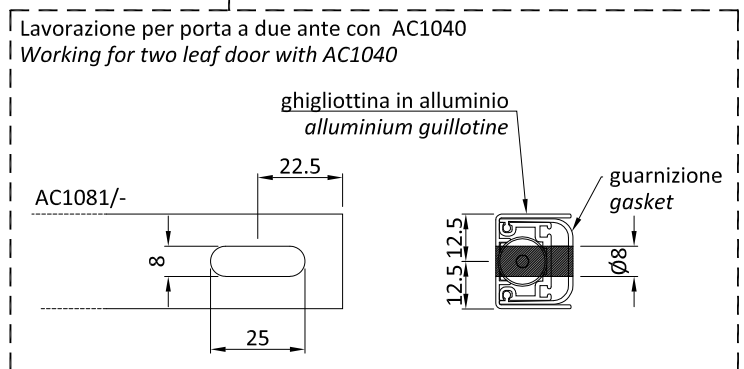
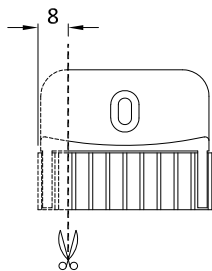
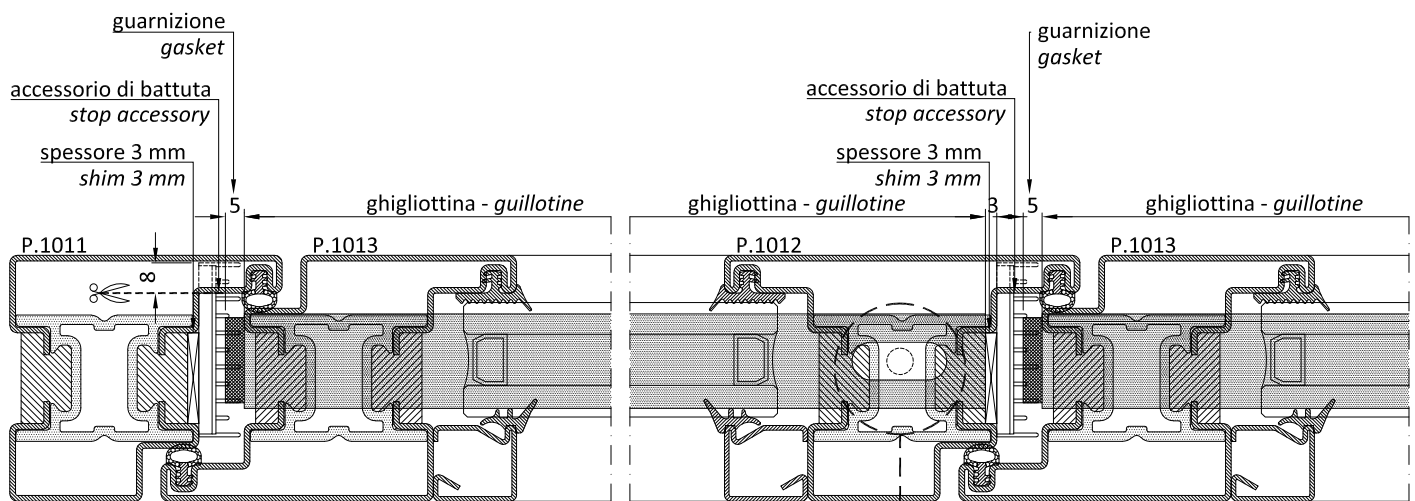
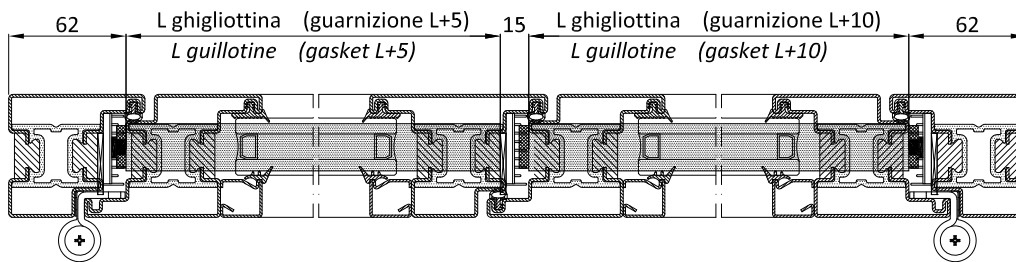
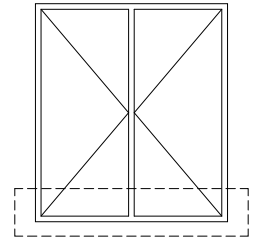

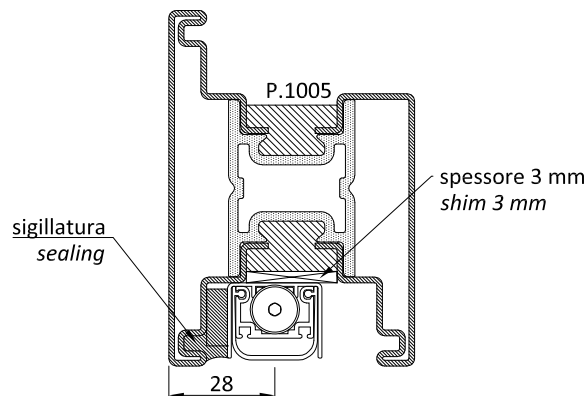
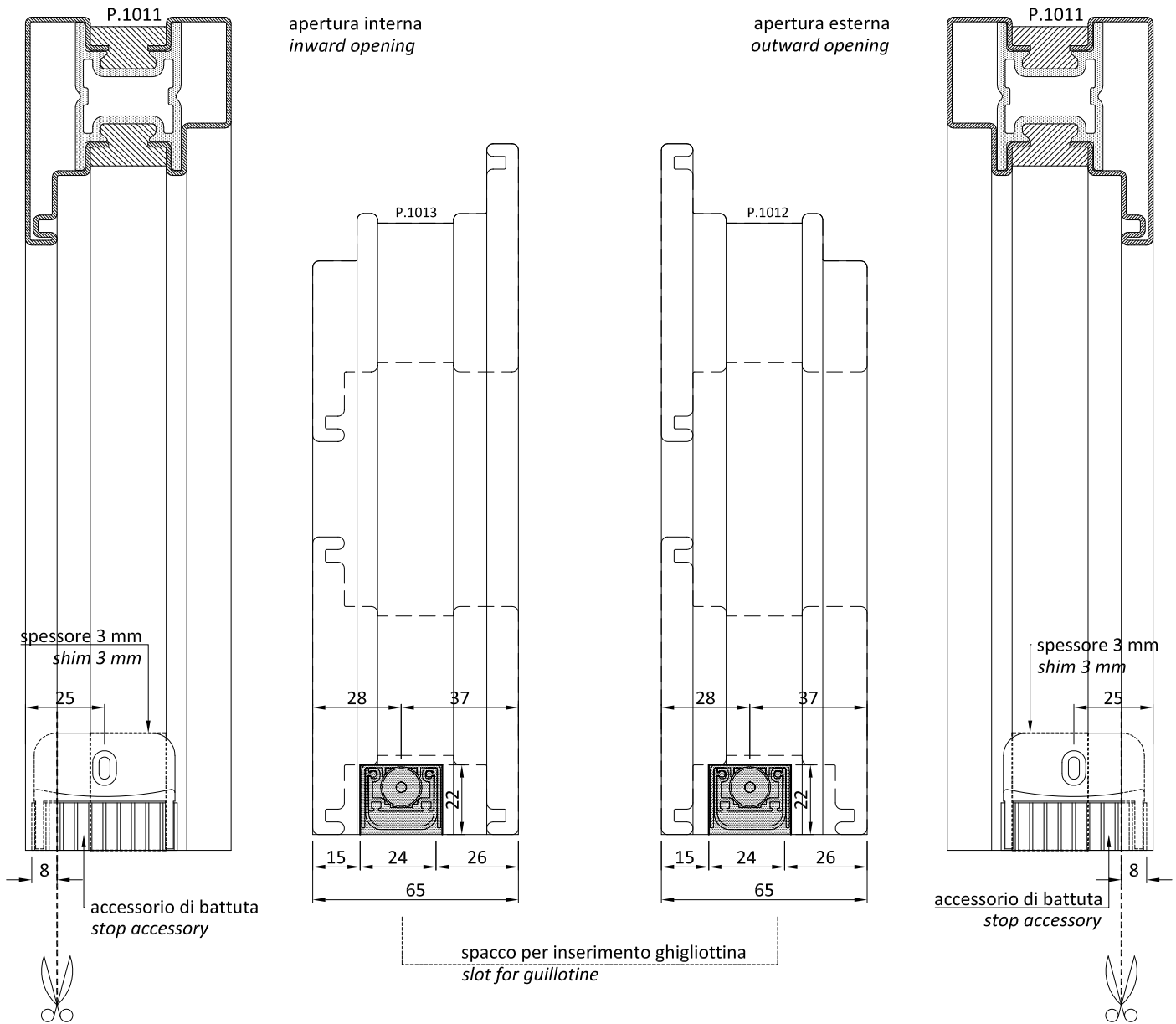
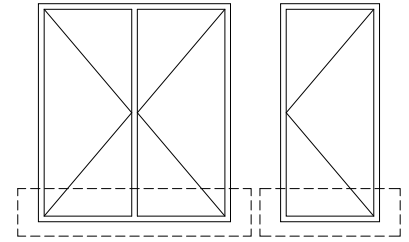

viti in dotazione  
supplied screws



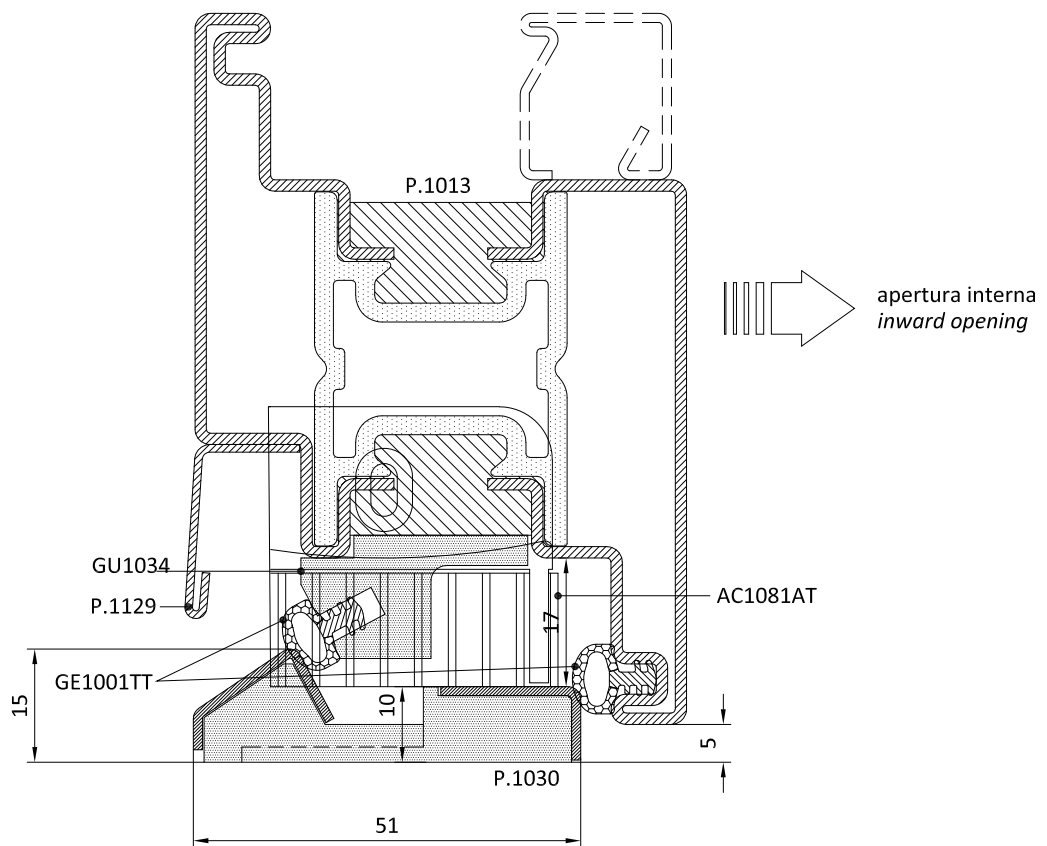
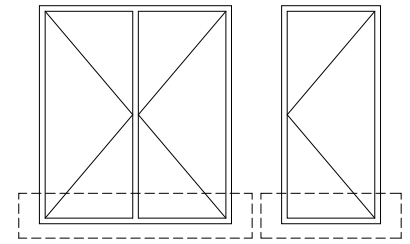

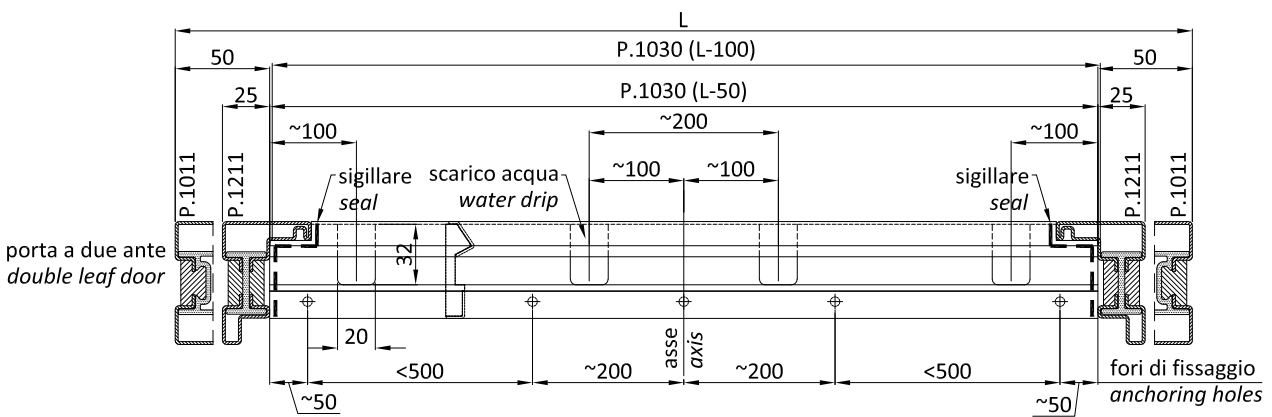
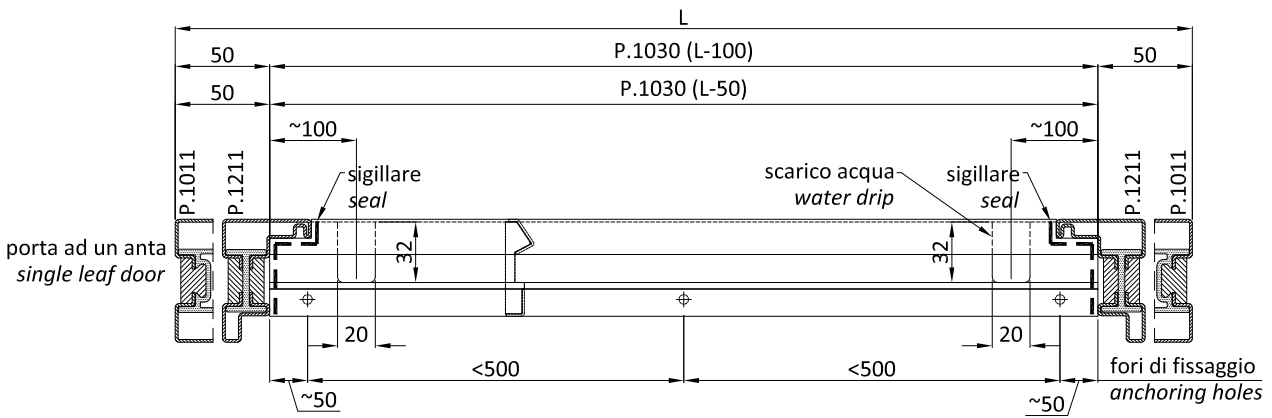
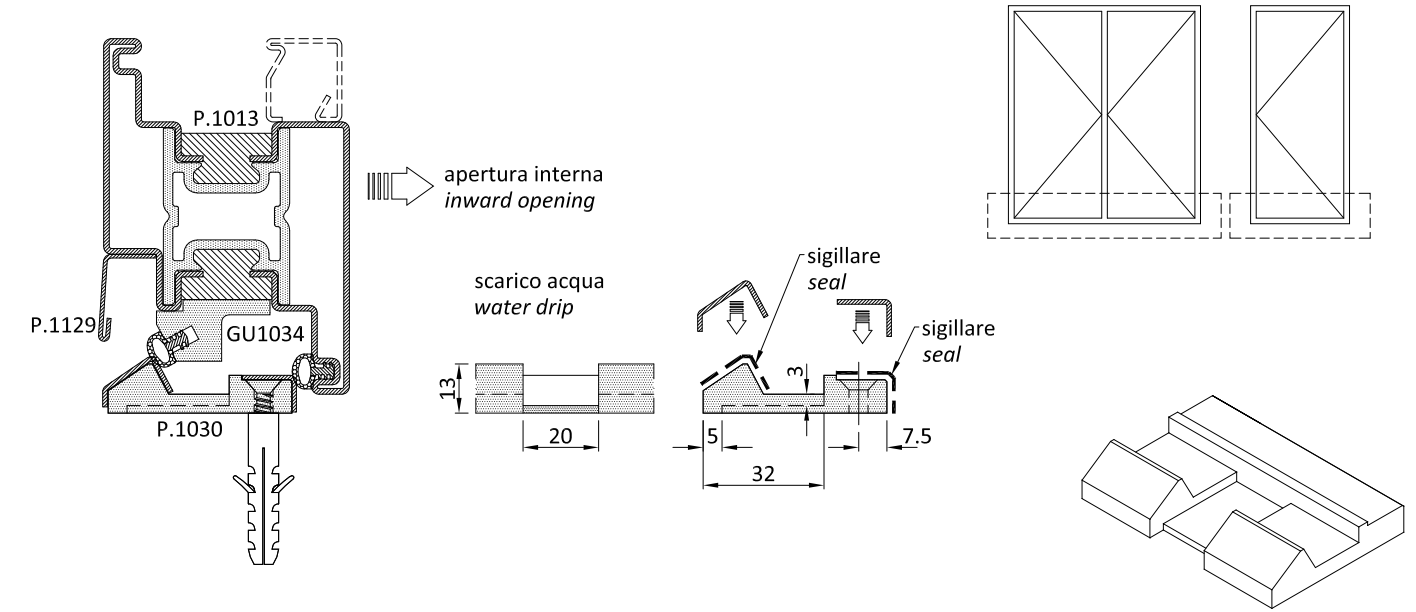



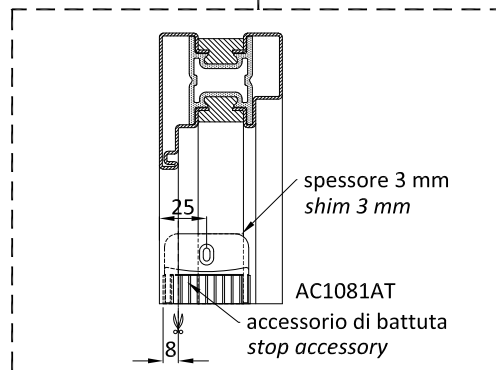
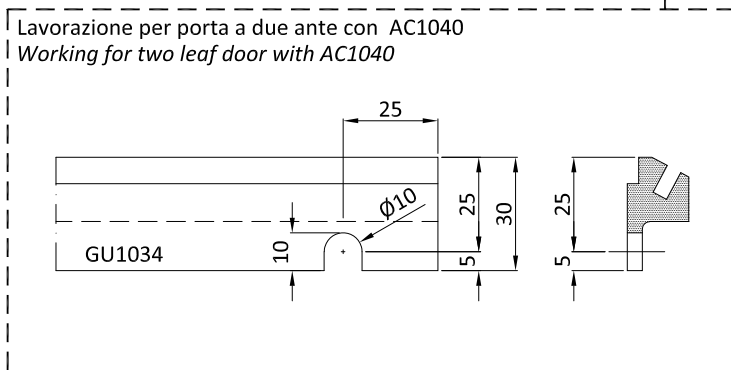
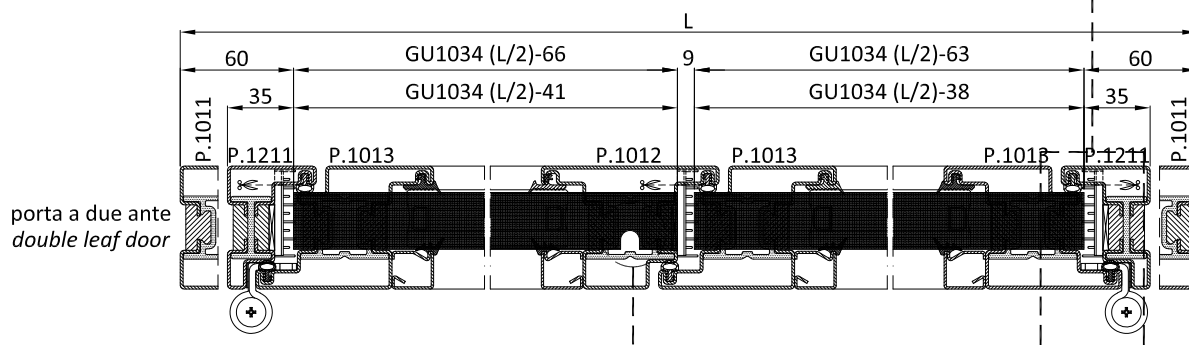
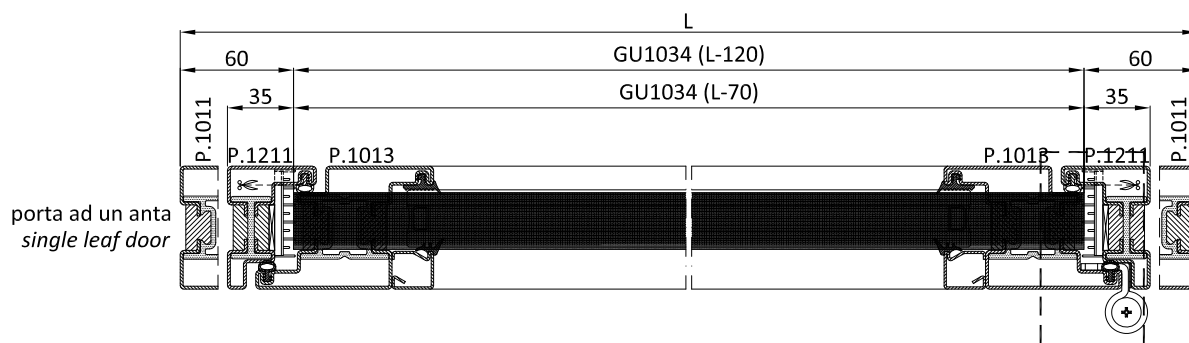
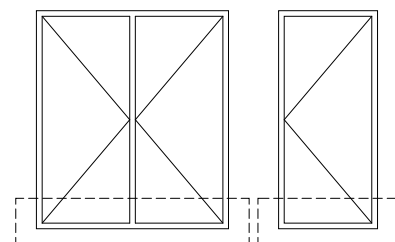
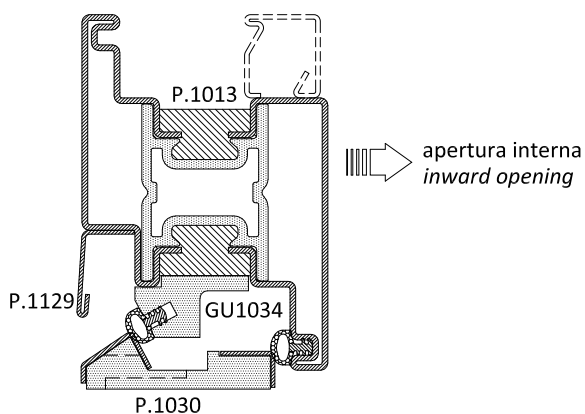

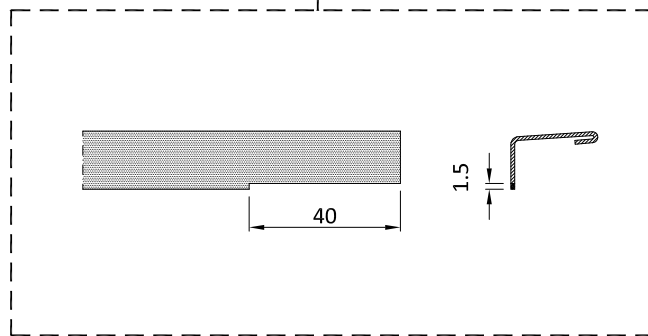
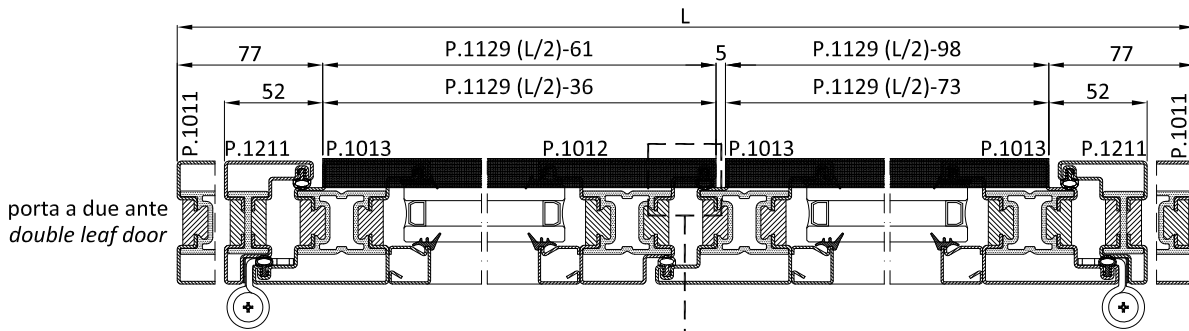
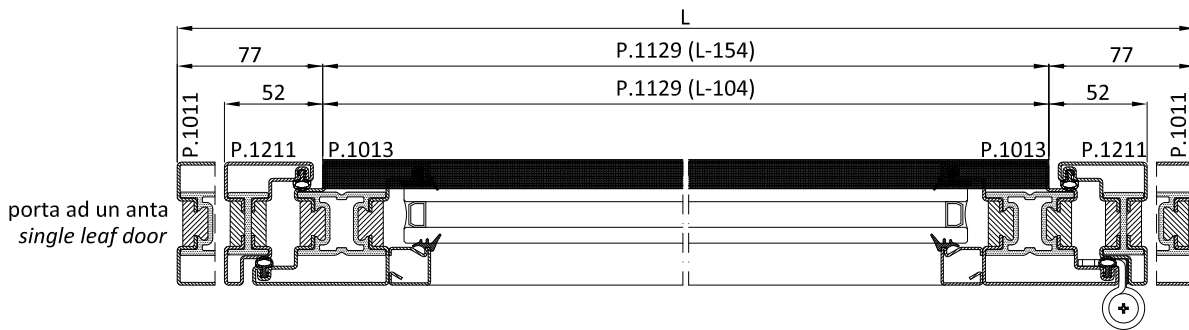
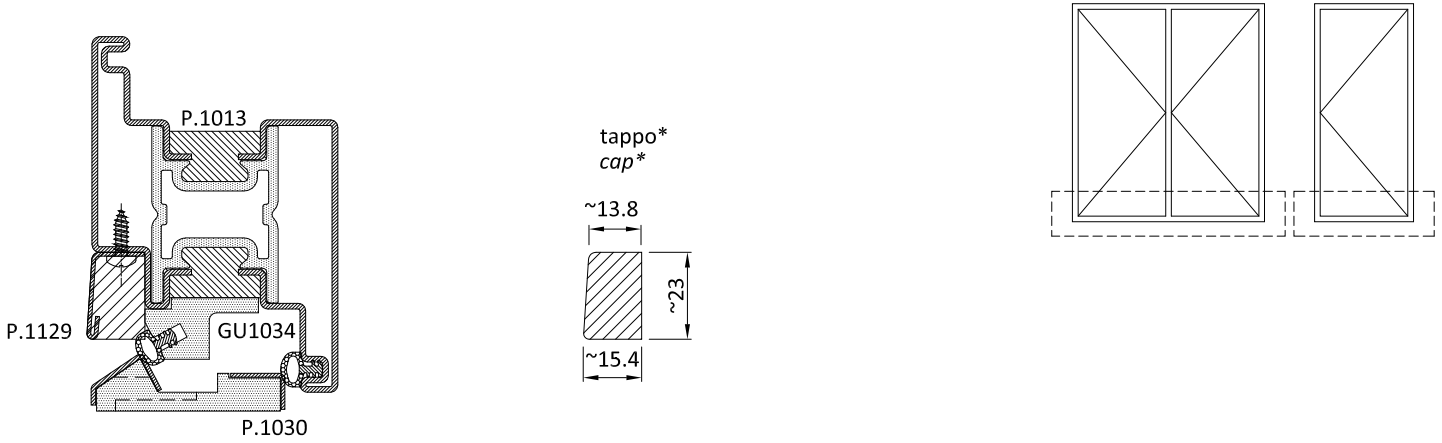

\*non forniti  
\*not included

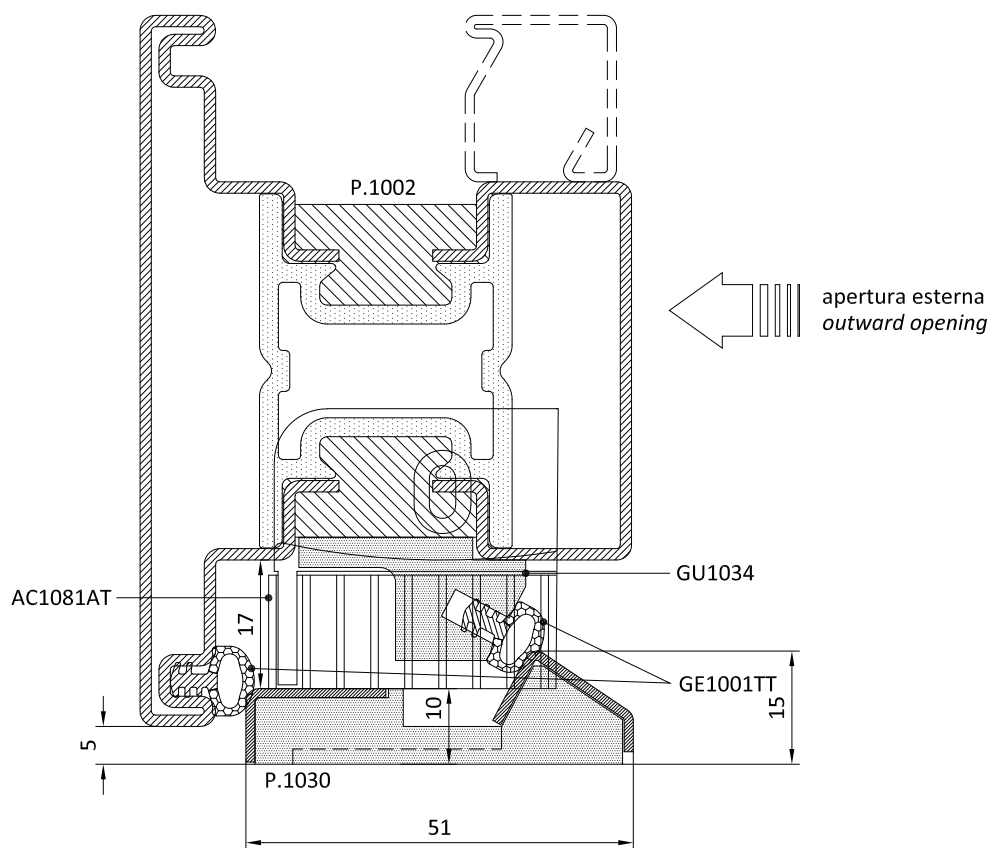
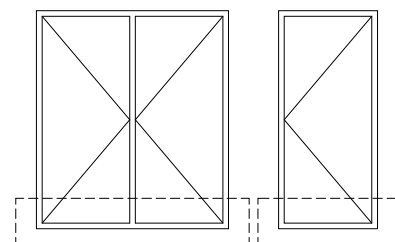

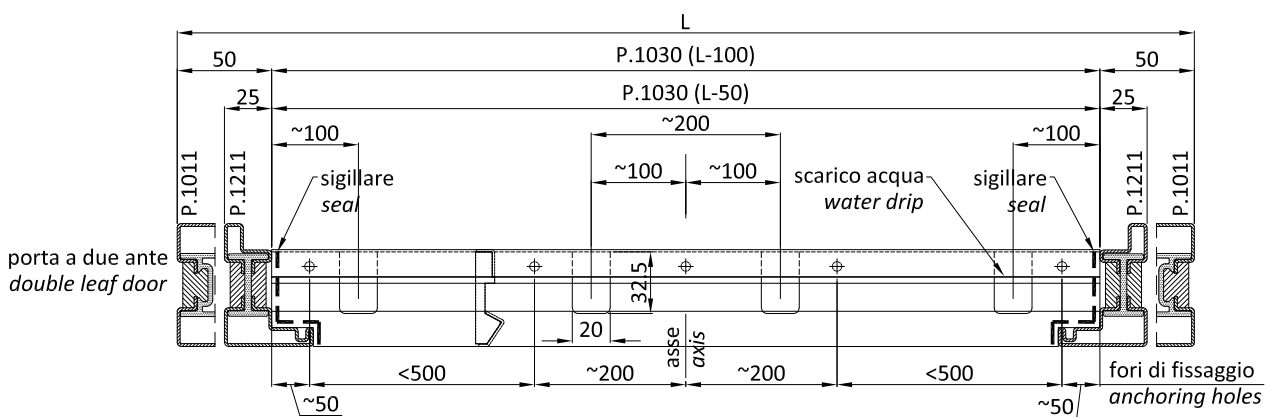
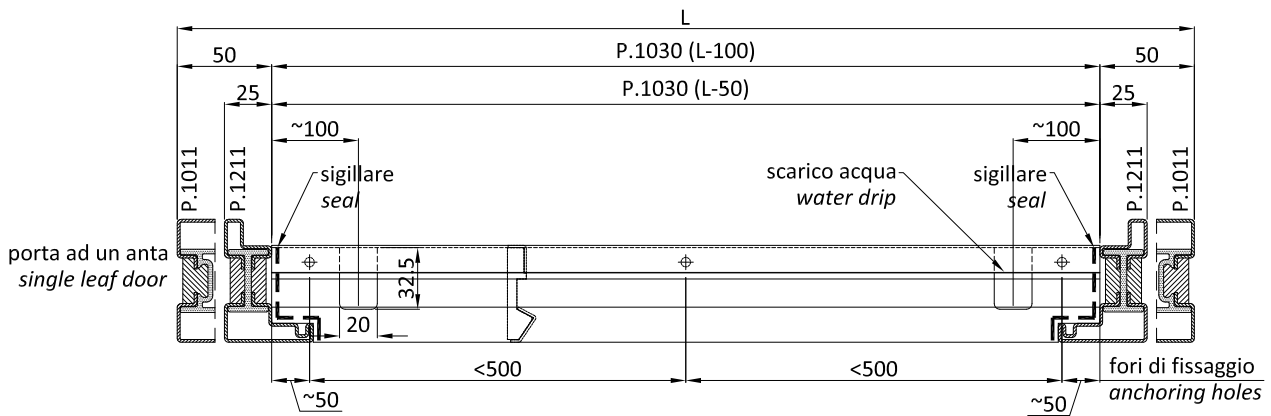
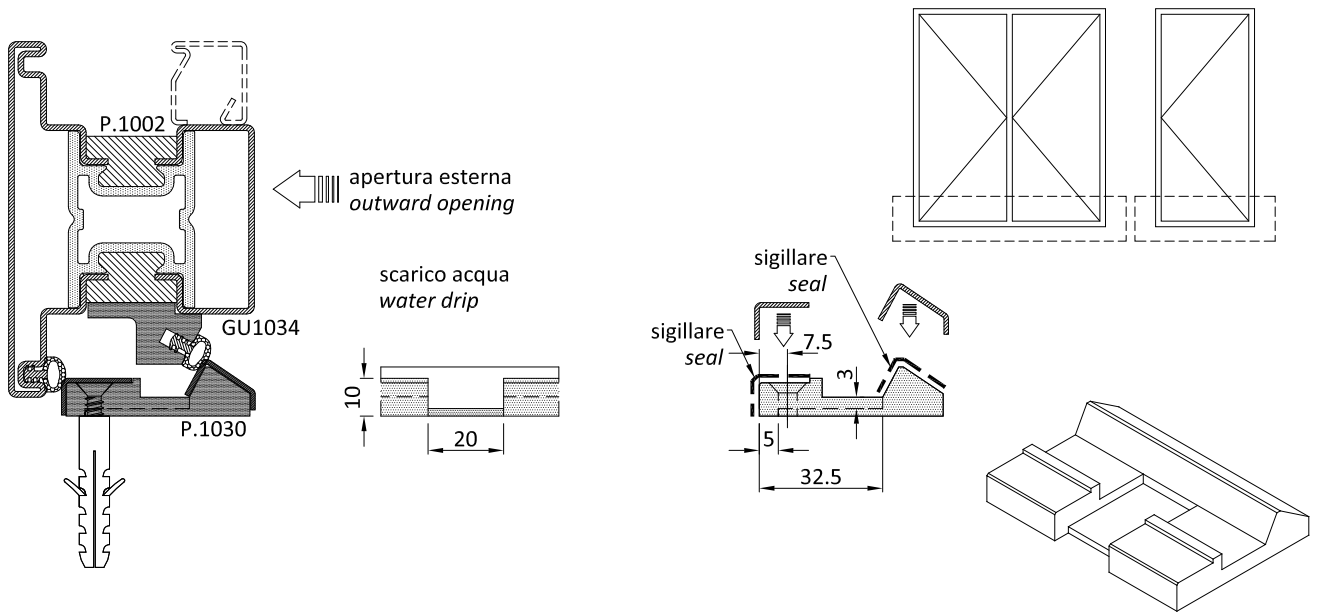

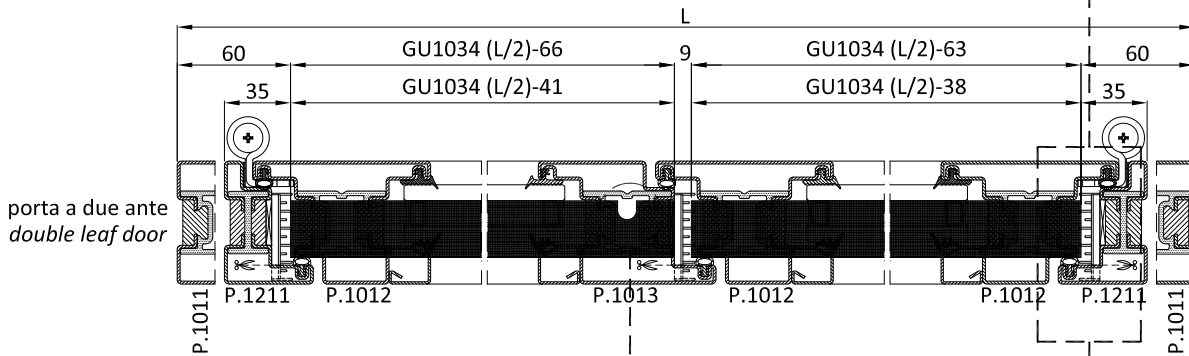
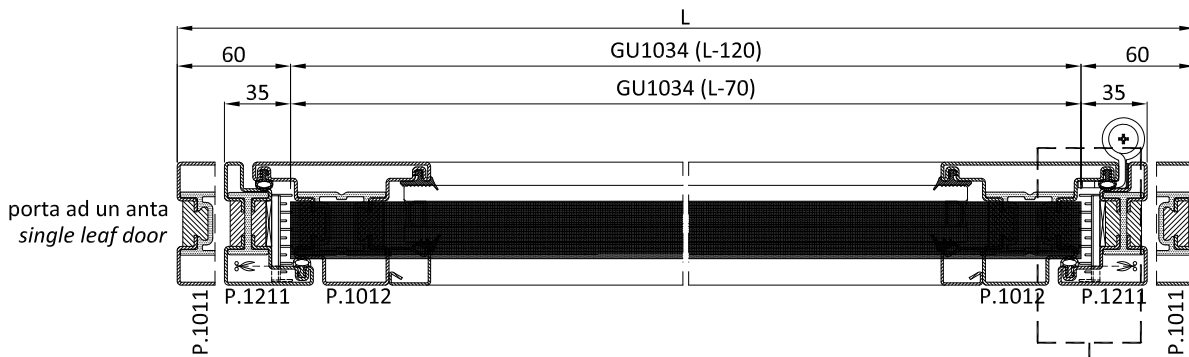
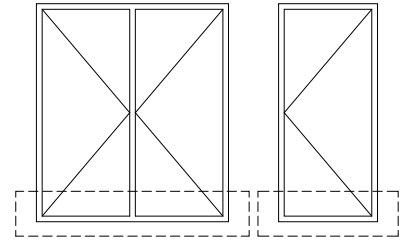
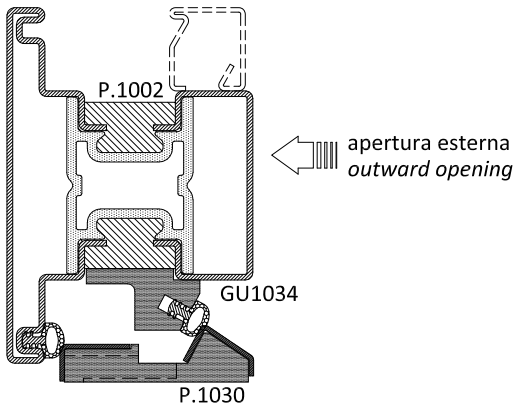

Lavorazione per porta a due ante con AC1040  
Working for two leaf door with AC1040

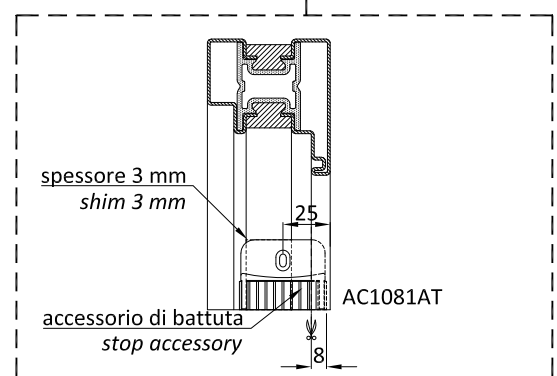
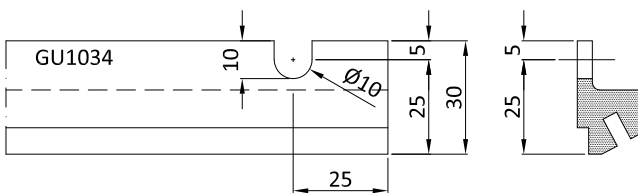

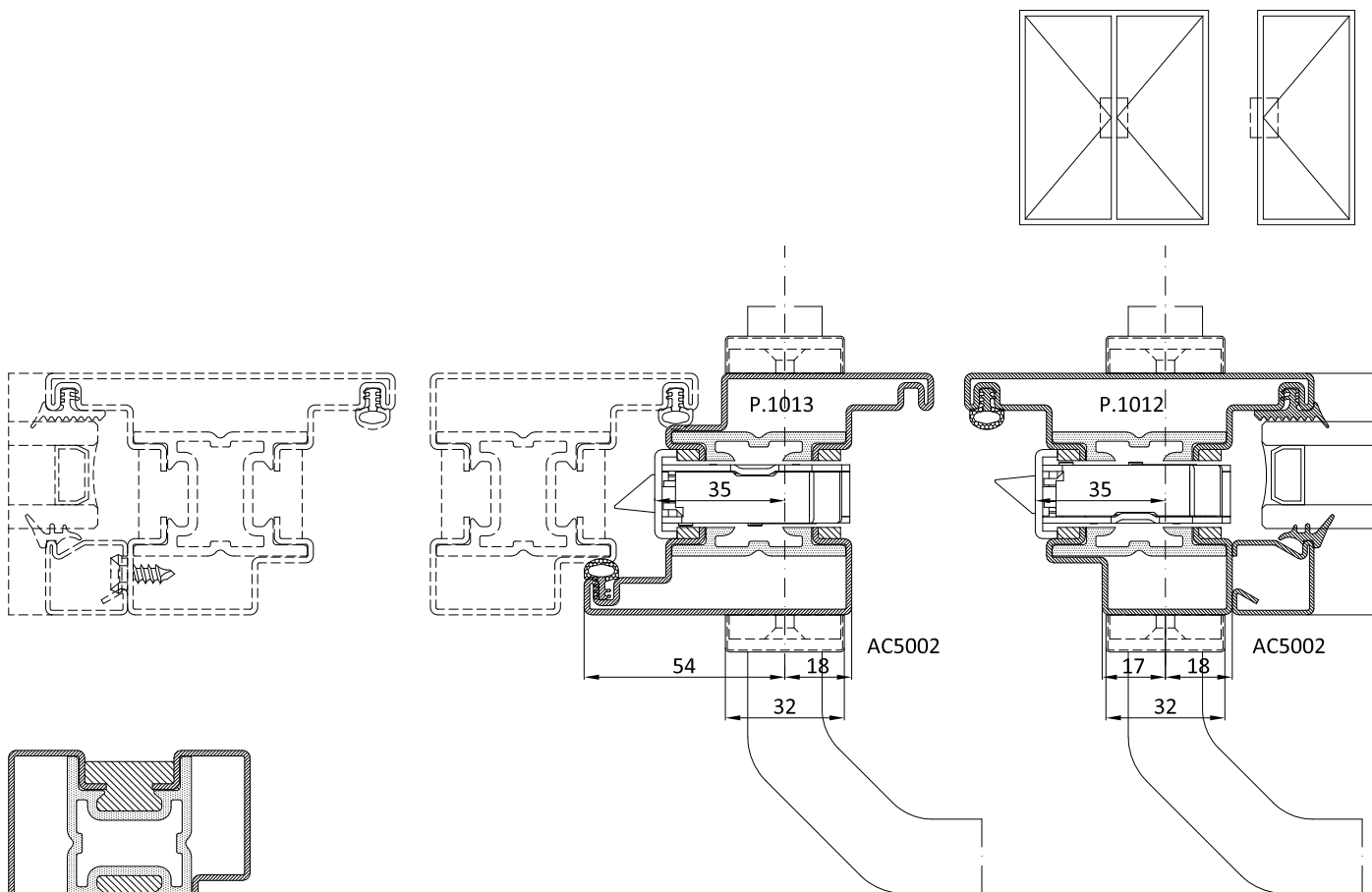

AC5002 :

- 1) Impugnatura
- 2) Rosetta
- 3) Corpo maniglia
- 4) Vite TPS 3.9x15.9
- 5) Quadro

AC5002 :

- 1) Handle grip
- 2) Washer
- 3) Handle body
- 4) Countersunk head screws 3.9x15.9
- 5) Spindle bar

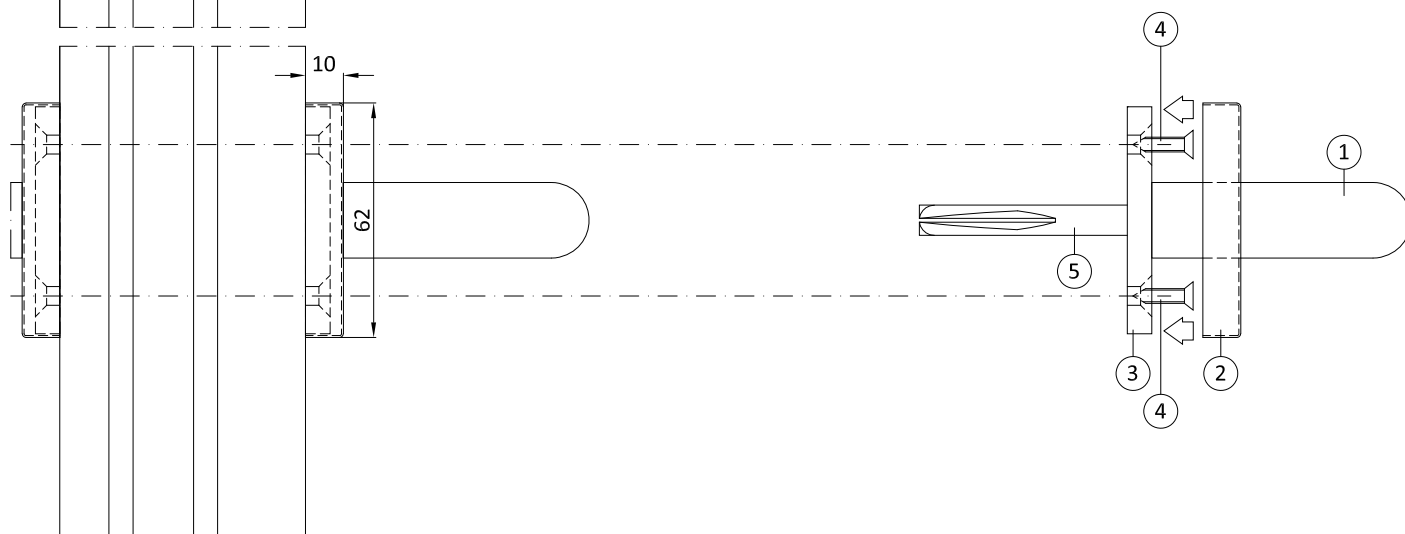

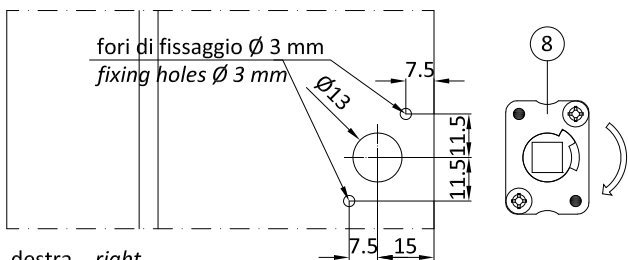

destra \_right  
Lavorazione speculare per anta SX  
Same working for left hand

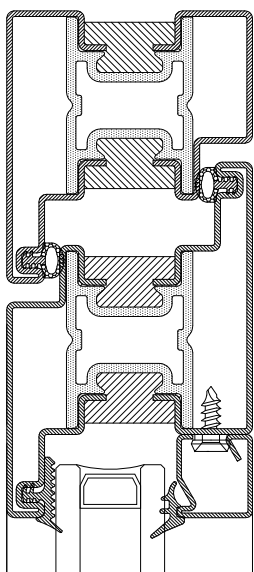
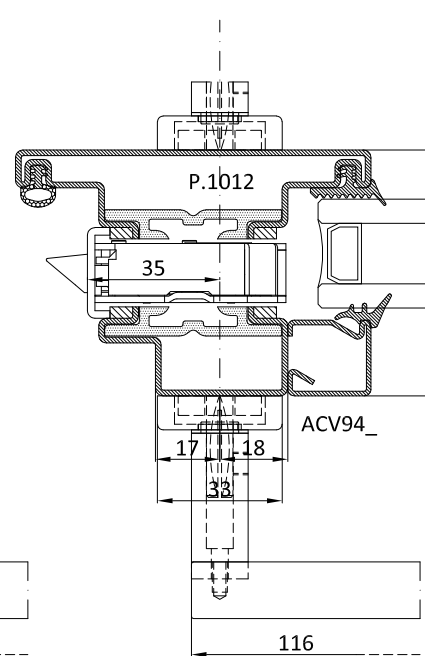
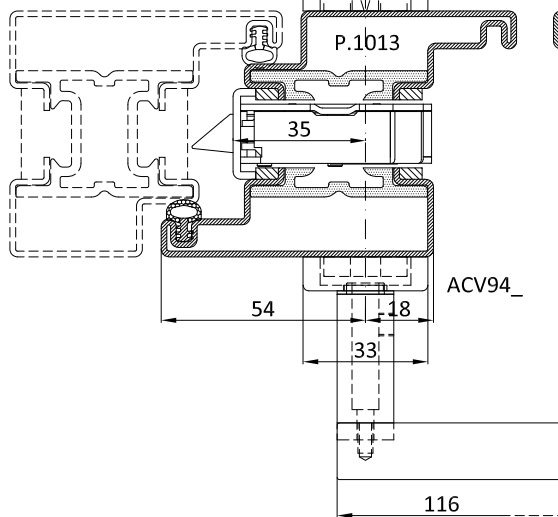
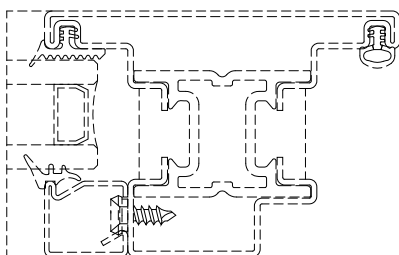

ACV94- :

- 1) Impugnatura
- 2) Rondella
- 3) Rosetta
- 4) Grano M6x6
- 5) Quadro
- 6) Vite TC 3.5x12.7
- 7) Molla

ACV94- :

- 1) Handle grip
- 2) Ring
- 3) Rose
- 4) Dowel M6x6
- 5) Spindle bar
- 6) Flat head screws 3.5x12.7
- 7) Spring

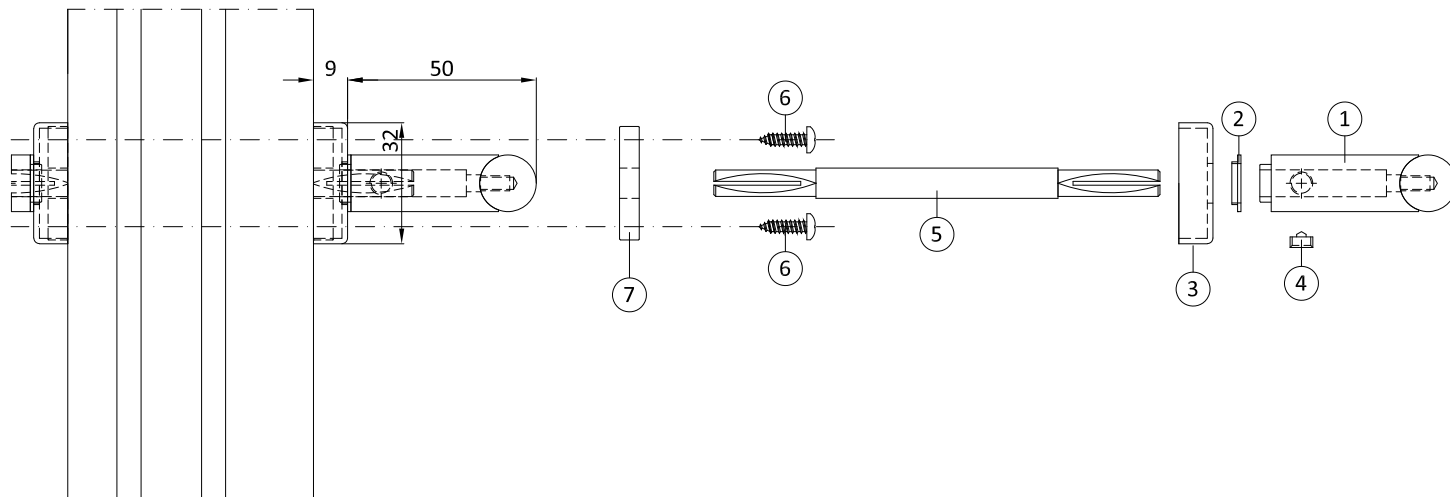

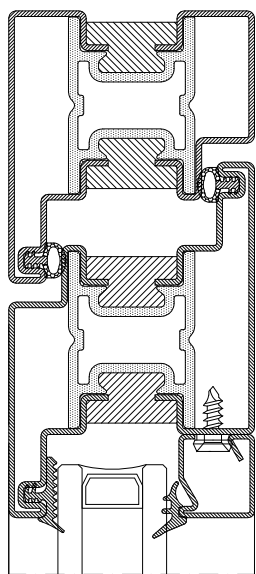
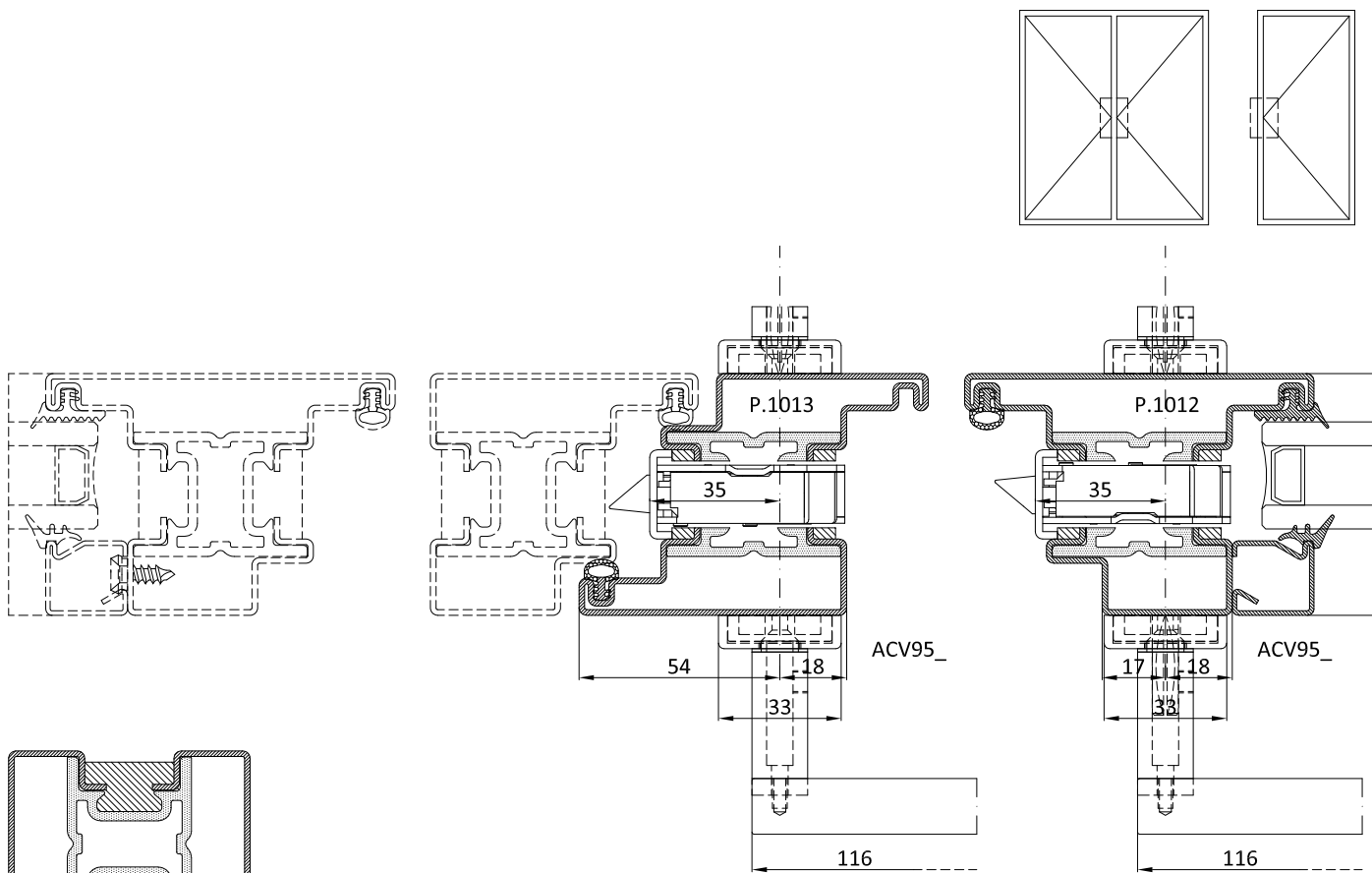

ACV95- :

- 1) Impugnatura
- 2) Rondella
- 3) Rosetta
- 4) Grano M6x6
- 5) Quadro
- 6) Vite TPS 3.9x15.9
- 7) Adattatore per molla
- 8) Molla

ACV95- :

- 1) Handle grip
- 2) Ring
- 3) Rose
- 4) Dowel M6x6
- 5) Spindle bar
- 6) Countersunk head screws 3.9x15.9
- 7) Adapter for spring
- 8) Spring

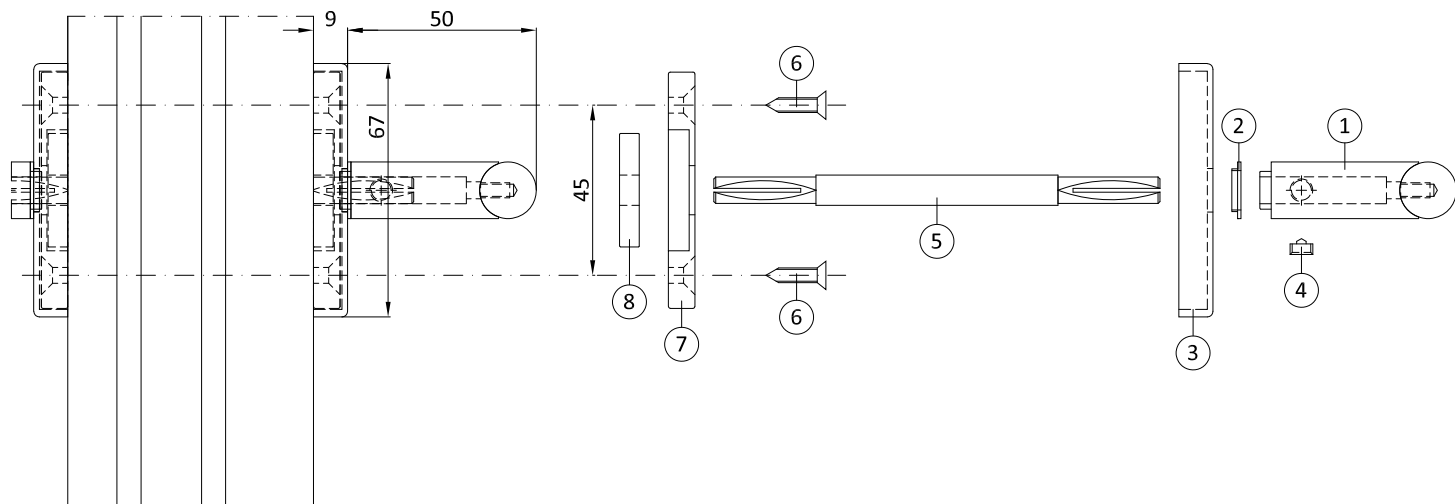



Porta | Door

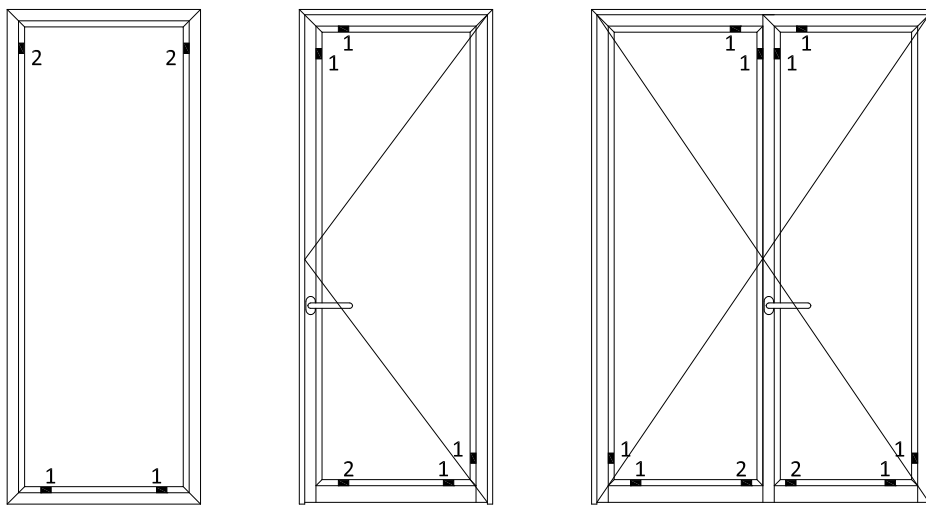

1) spessore portante | carry shim

2) spessore distanziatore | compensation shim

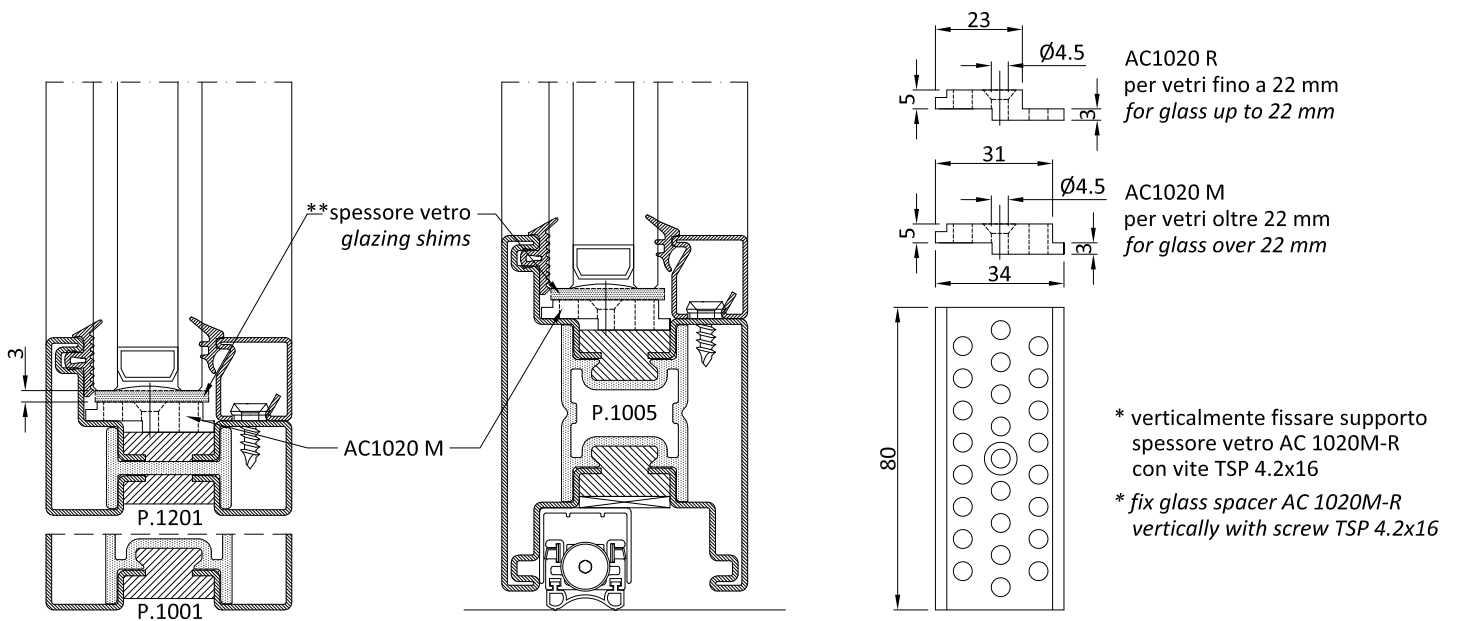

Note / Note

- La larghezza degli spessori è almeno pari o maggiore (+2 mm) dello spessore del vetro installato.
- La posizione degli spessori deve essere garantita dall'utilizzo di materiale adeguato che ne eviti lo spostamento.
- The shims' width is the same or greater (+2 mm) than the thickness of the glass installed.
- The position of the shims has to be ensured by using appropriate material that avoids creeping.

\* vite TSP 4.2 x 16 mm non inclusa - screw TSP 4.2 x 16 mm not included

\*\* spessori vetro non inclusi - glass thickness not included



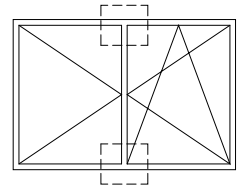
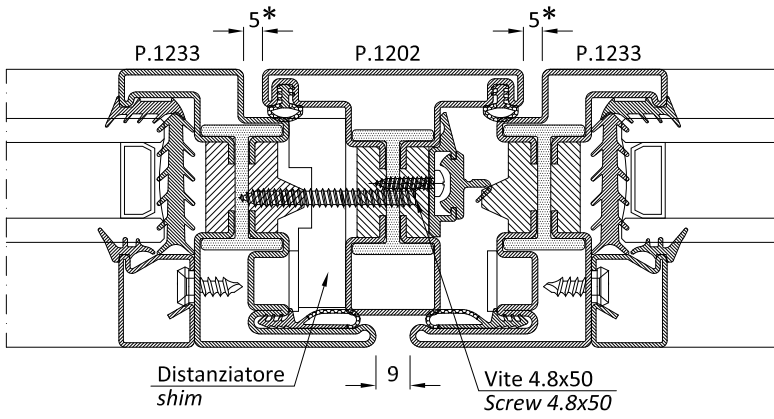

A = Fori di fissaggio P.1202 con P.1233  
A = Anchoring holes P.1202 with P.1233

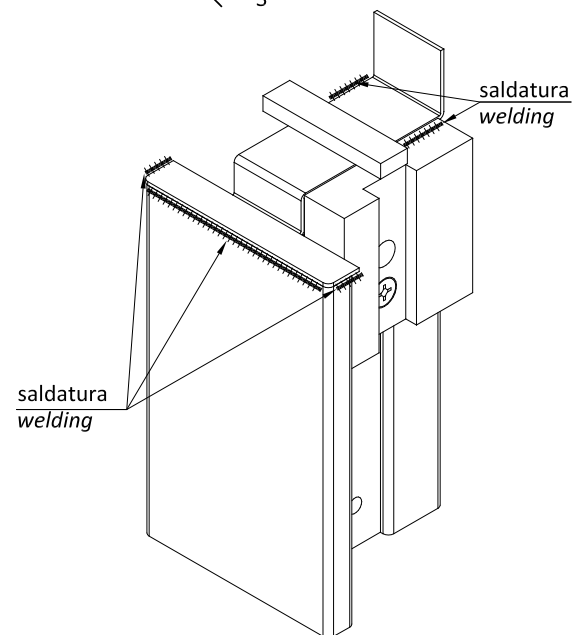
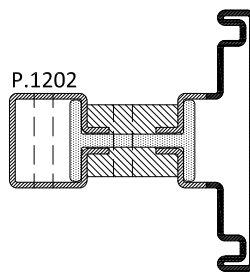
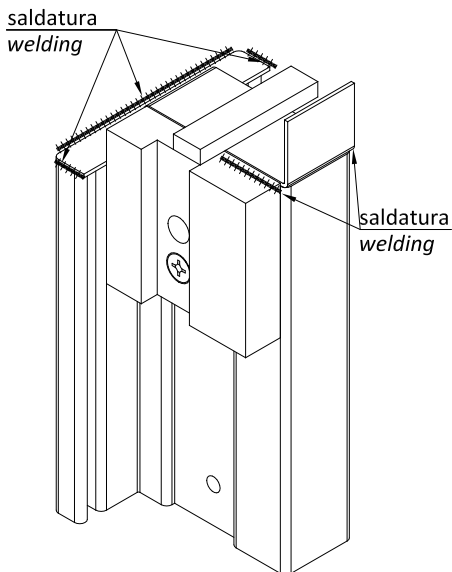
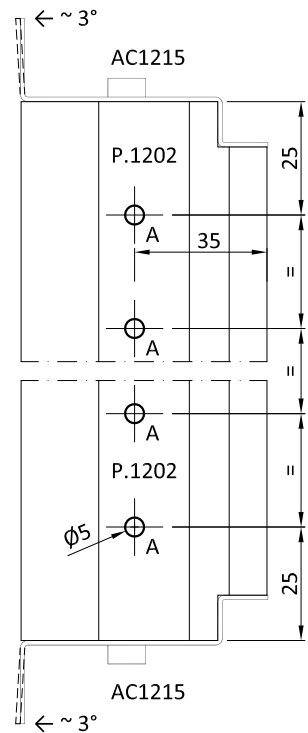
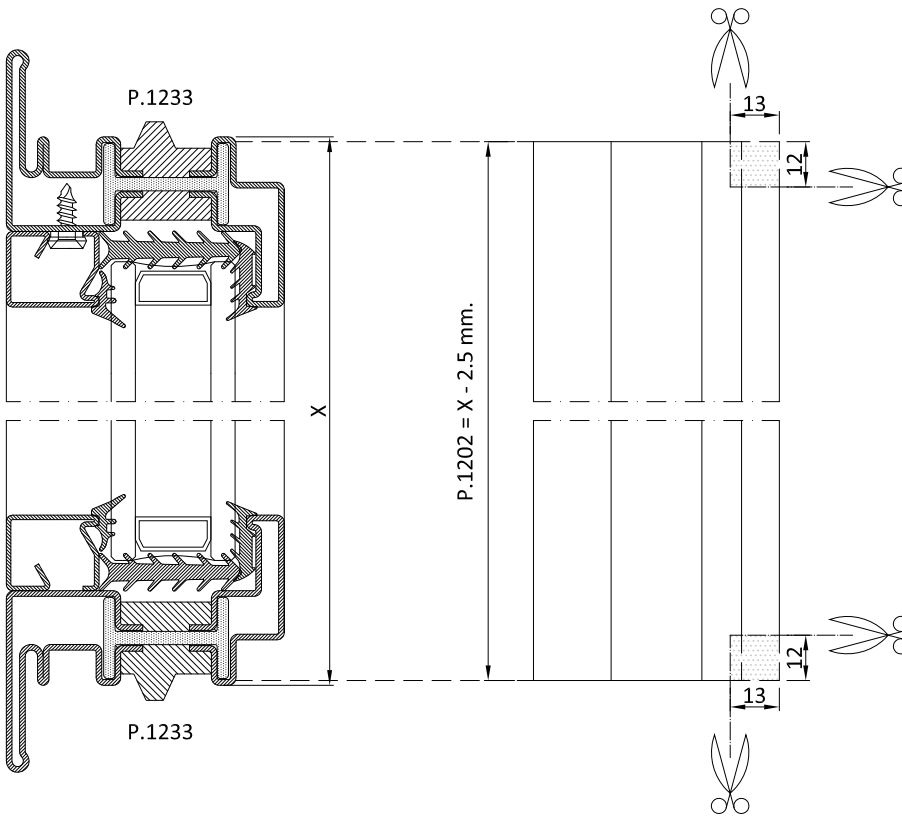

Saldare e sigillare l'accessorio AC1215 al profilo montante P.1202  
Weld and seal AC1215 to P.1202 transom profile

\* Vedi tabella 4.1.5  
\* See chart 4.1.5

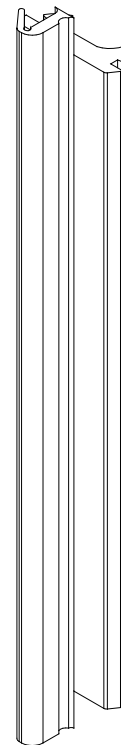
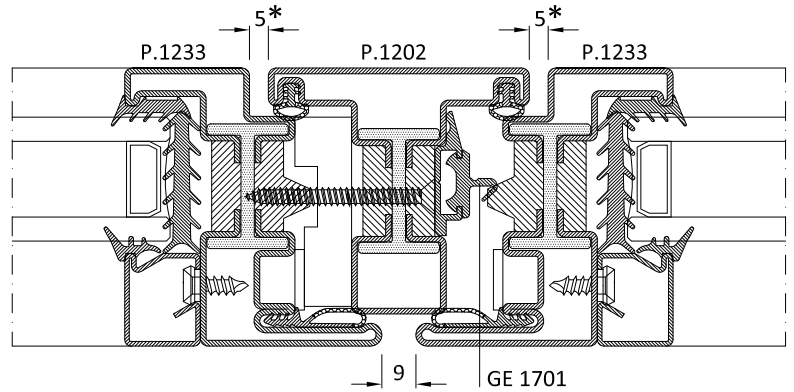
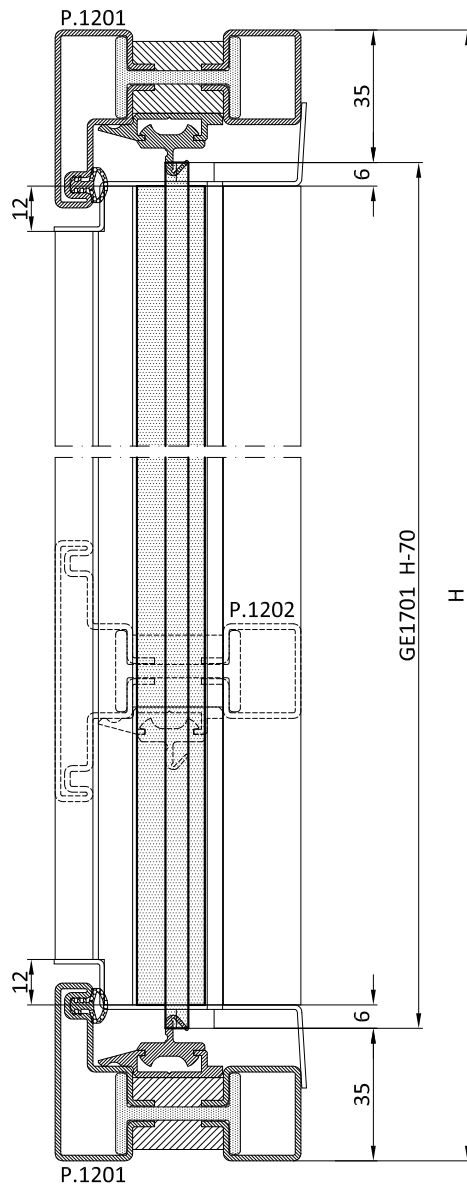
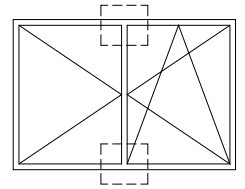

\* Vedi tabella 4.1.5  
\* See chart 4.1.5

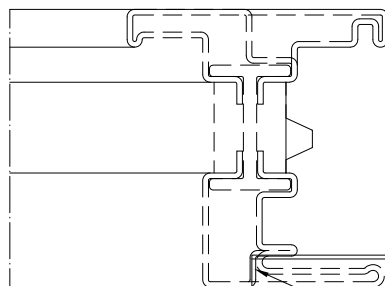
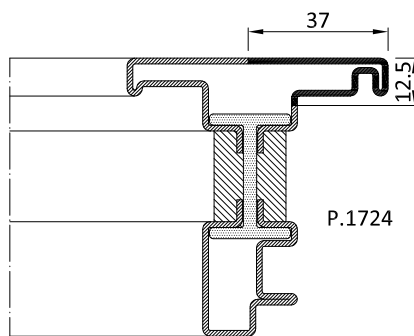
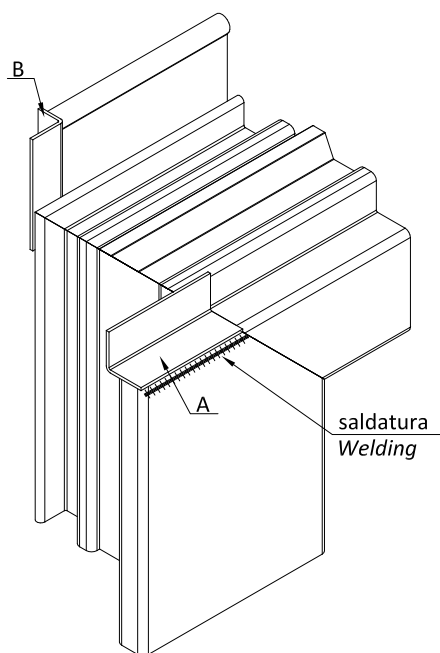
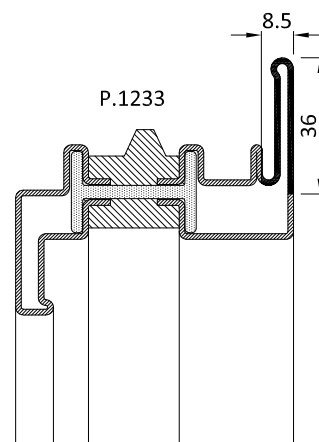
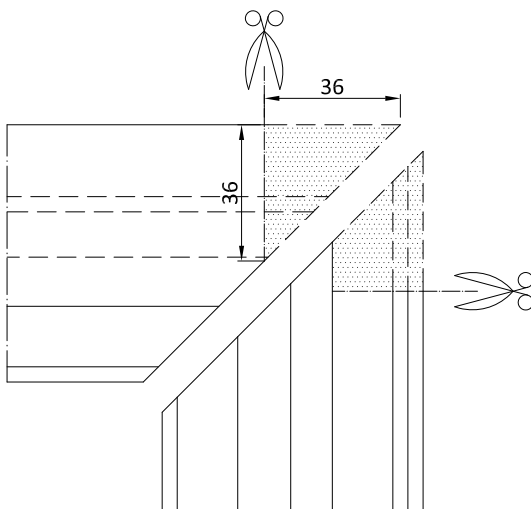
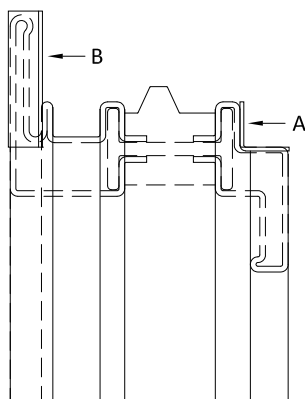
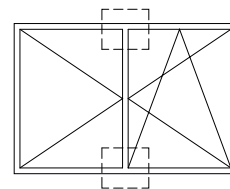
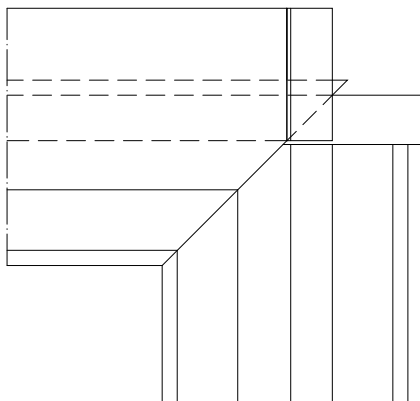
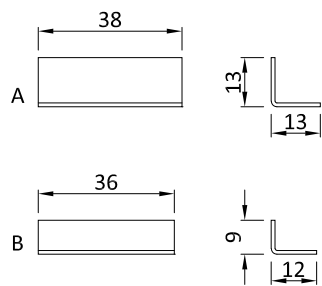

porzione da rifilare e saldare dopo l'assieme dell'angolo  
area to cut and weld after the corner joint

Nota: i fondini sono forniti di dimensioni maggiori da rifilare dopo la saldatura.  
Note: the ending caps for T-Z joint are furnished in larger dimensions and should be trimmed down after welding.

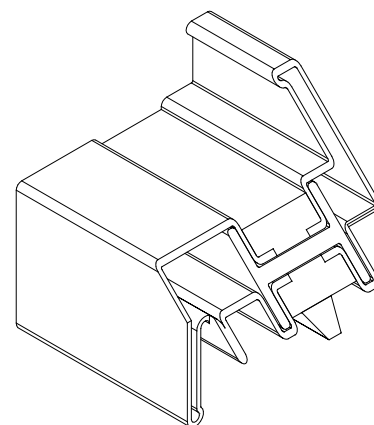
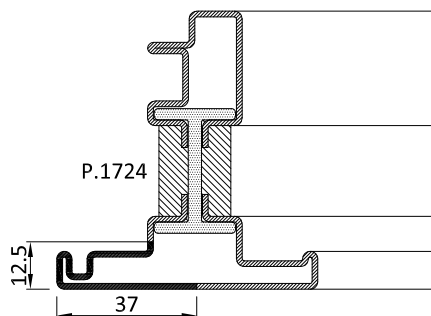
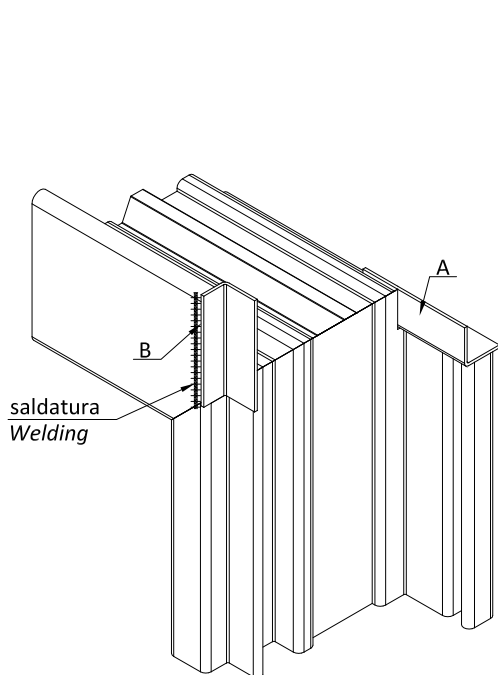
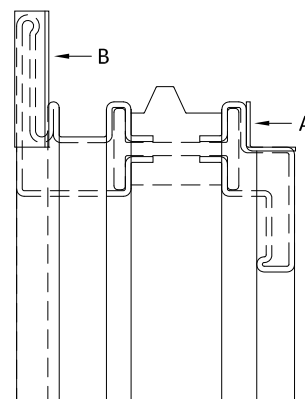
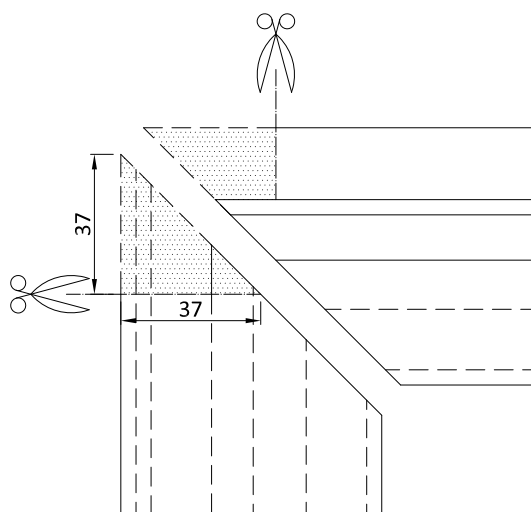
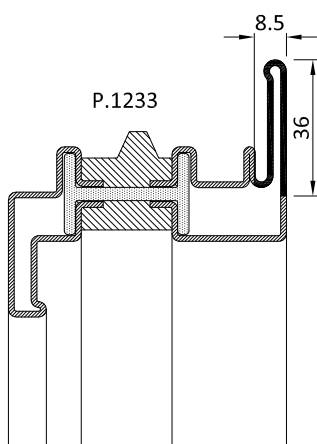
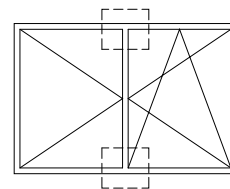
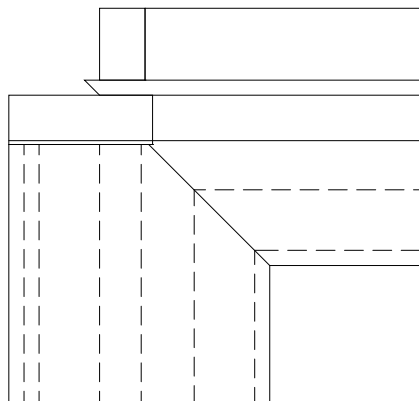
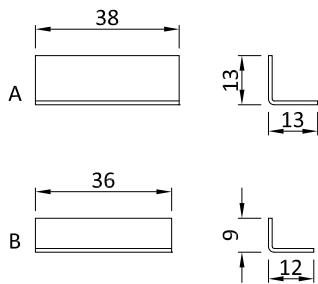

Nota: i fondini sono forniti di dimensioni maggiori da rifilare dopo la saldatura.  
Note: the ending caps for T-Z joint are furnished in larger dimensions and should be trimmed down after welding.

- 1) Asportare il poliammide.
- 1) Remove the polyamide.
- 2) Tagliare la guarnizione GE1704 a 50 mm. dal filo esterno del polliamide.
- 2) Cut the gasket GE1704 at 50 mm from the end thread of polyamide.
- 3) Asportare la la parte dell'estruso GU1702 che interferisce con il fondino A.
- 3) Remove the part of the extrudate GU1702 that interferes with the rubber ending cap A.
- 4) Posizionare il fondino di gomma ed incollarlo alla guarnizione GE1701 a mezzo di colla ciano-acrilica.
- 4) Position the rubber ending cap and stick it to the gasket GE1701 with cyano-acrylic glue

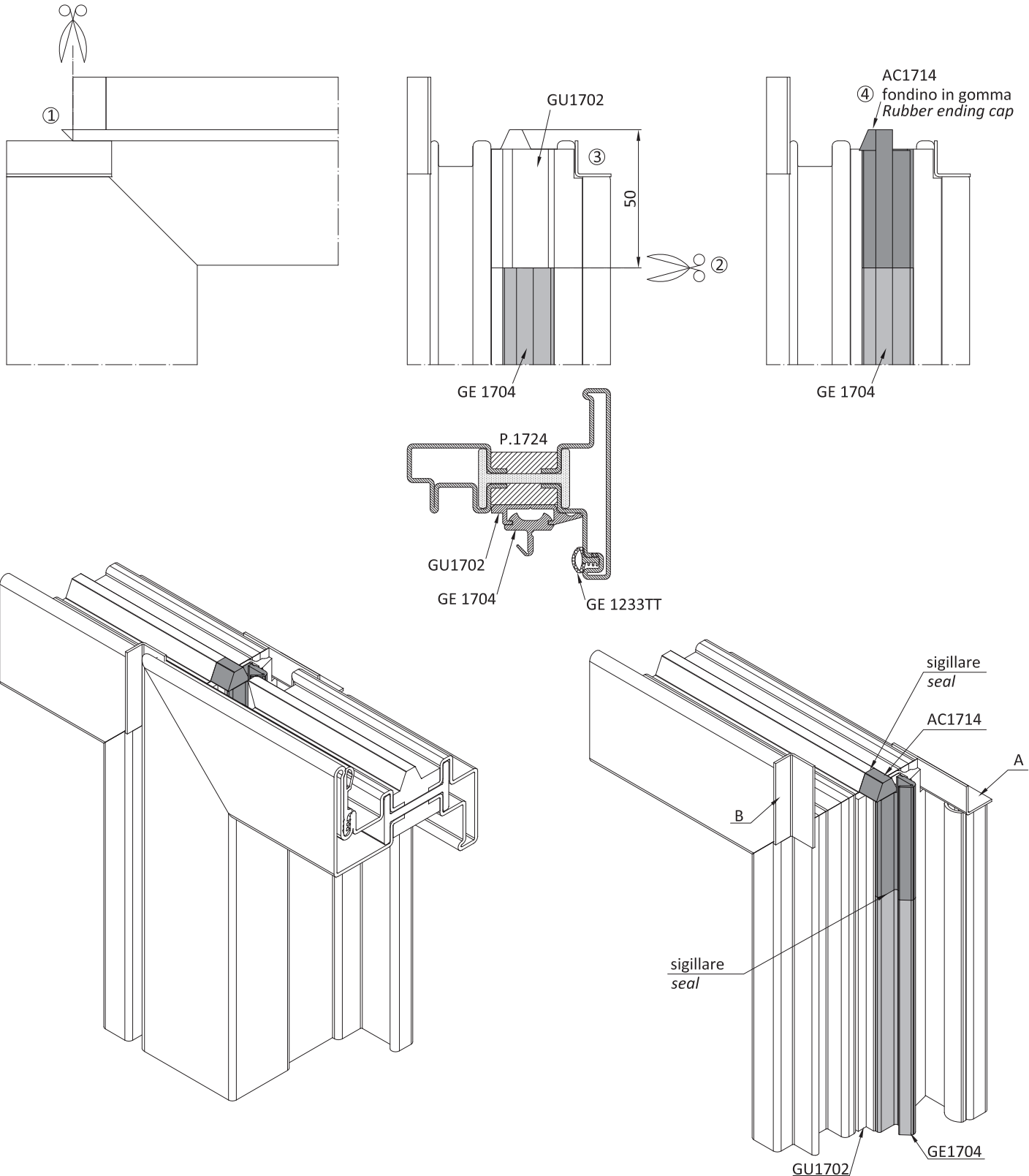
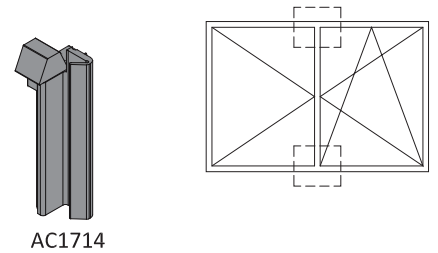

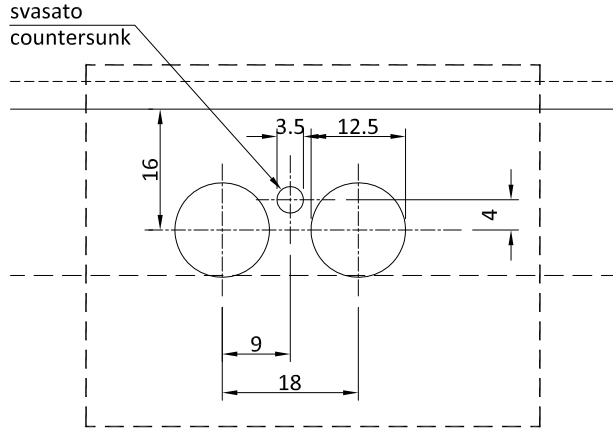
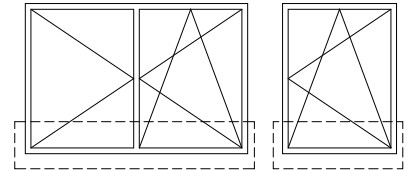

Particolare A - Detail "A"

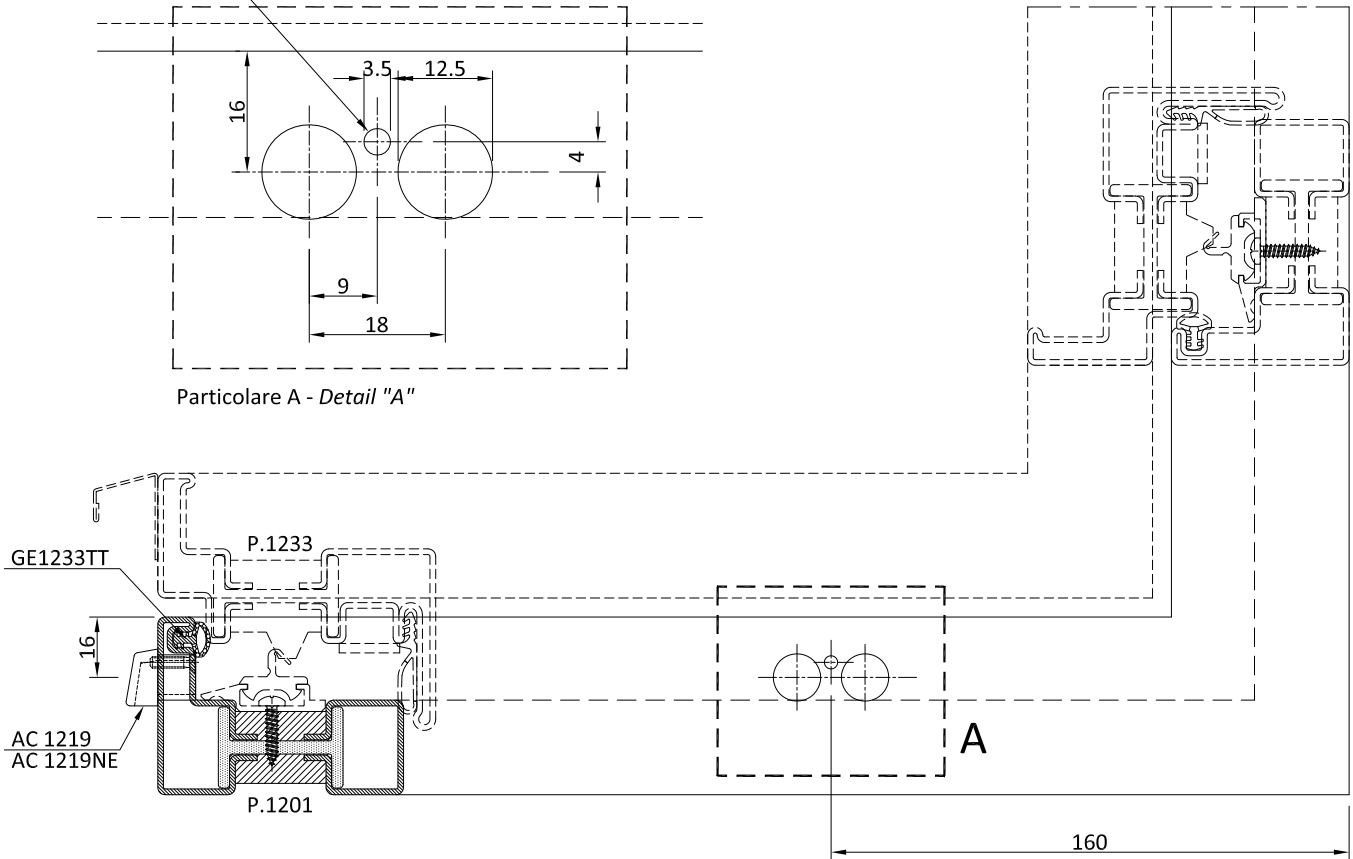

Tagliare la guarnizione per 20 mm | Cut the gasket to 20 mm

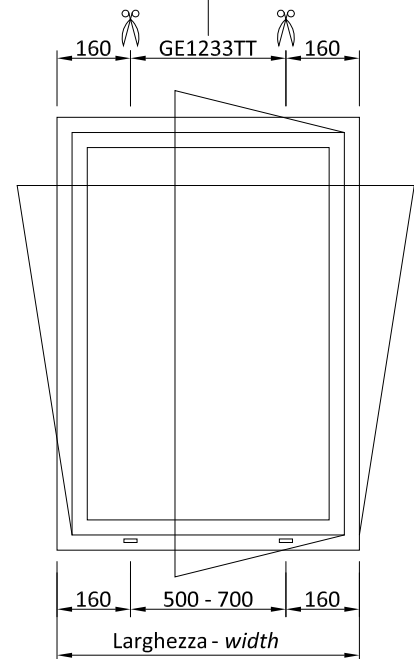
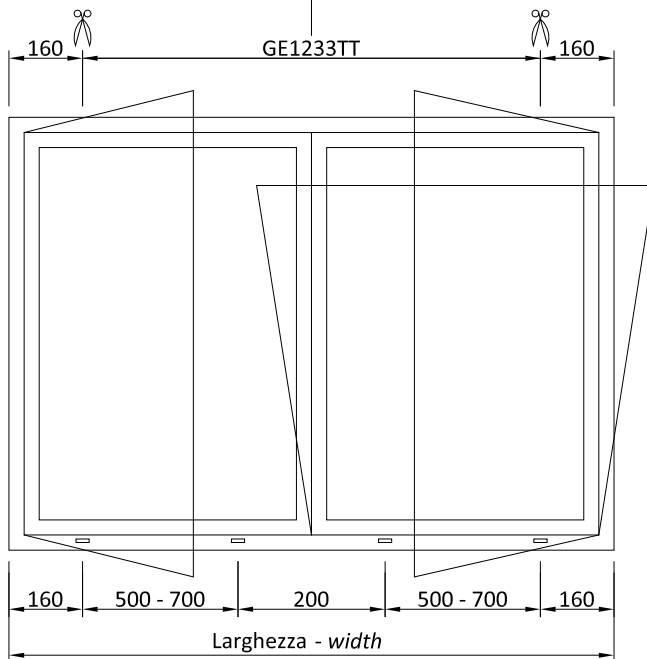

- 1) Eseguire i fori come da disegno .
- 2) Posizionare lo scarico acqua e sigillare fissare con viti in dotazione M3x12.
- 3) Posizionare il supporto della guarnizione di giunto GU1702 e fissarlo con viti TC 3.5x13 (non fornita).
- 4) Sigillare la guarnizione di giunto GE1701 con il supporto GU1702 per tutta lunghezza e per 200 mm. in altezza sul telaio.
- 5) Posizionare la guarnizione di giunto centrale GE1701 e gli angoli vulcanizzati AC1716, incollare gli angoli alla guarnizione a mezzo di colla ciano-acrilica.

- 1) Drill the holes according to drawing .
- 2) Install the water drip accessory, seal and secure with the supplied M3x12 screw.
- 3) Position the support of the weather strip GU1702 and anchor it with the double-sided adhesive tape provided and screws TC 3.5x13 (not provided).
- 4) Seal the weather strip GE1701 with the support GU1702 for the whole length and for 200 mm vertically on the frame.
- 5) Install the central weather strip GE1701 and the vulcanised corners AC1716, glue the corners to the weather strip using cyanoacrylate glue.

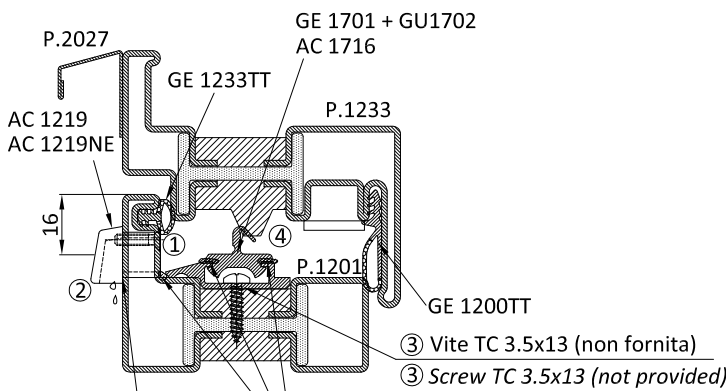
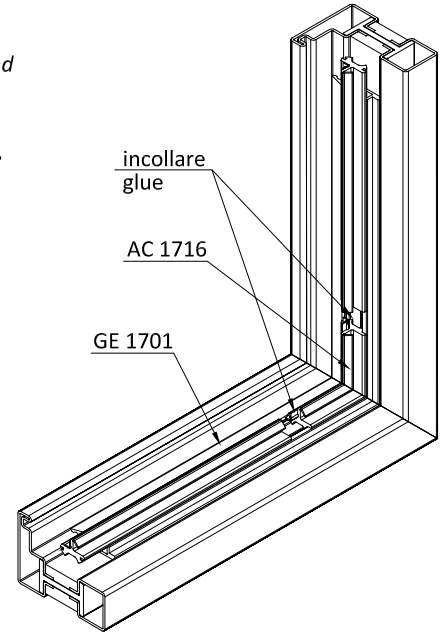
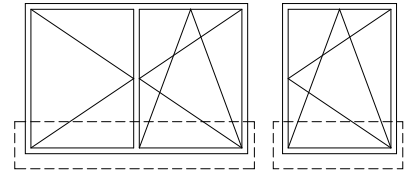

- ③ Vite TC 3.5x13 (non fornita)
- ③ Screw TC 3.5x13 (not provided)

- ④ sigillare per tutta la lunghezza la base inferiore e per 200 mm. in altezza il telaio.
- ④ Seal the lower frame for its whole length and for 200 mm vertically.

sigillare il perimetro dello scarico acqua  
seal the perimeter of water drip

incollare gli angoli vulcanizzati AC1716 alla guarnizione con colla cianoacrilica  
Glue the vulcanised corner AC1716 to the gasket using cyanoacrylate glue

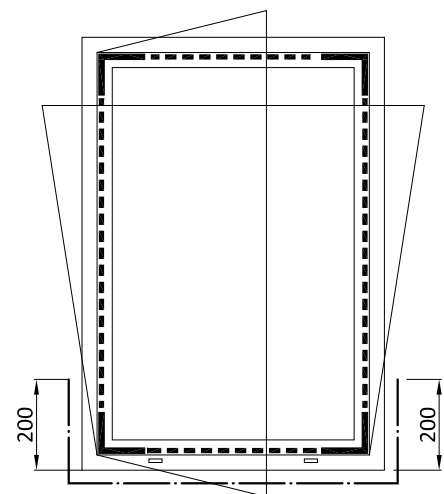
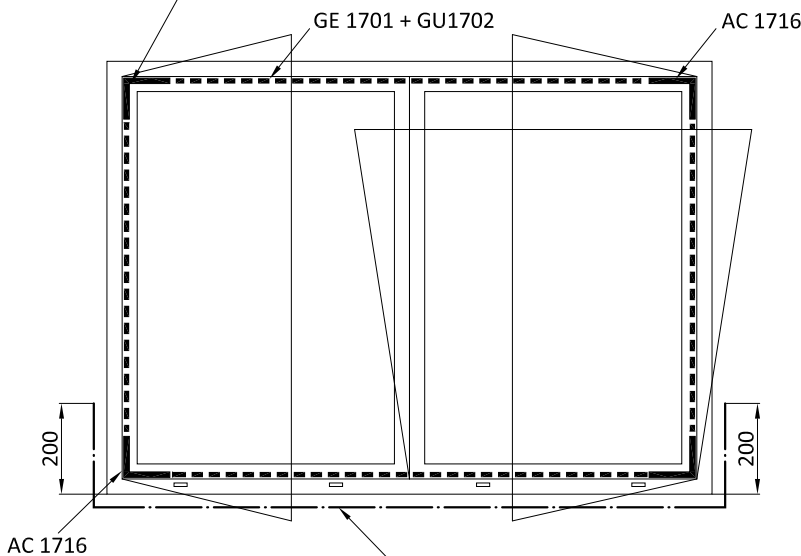

- ④ sigillare per tutta la lunghezza la base inferiore e per 200 mm. in altezza il telaio.
- ④ Seal the lower frame for its whole length and for 200 mm vertically.



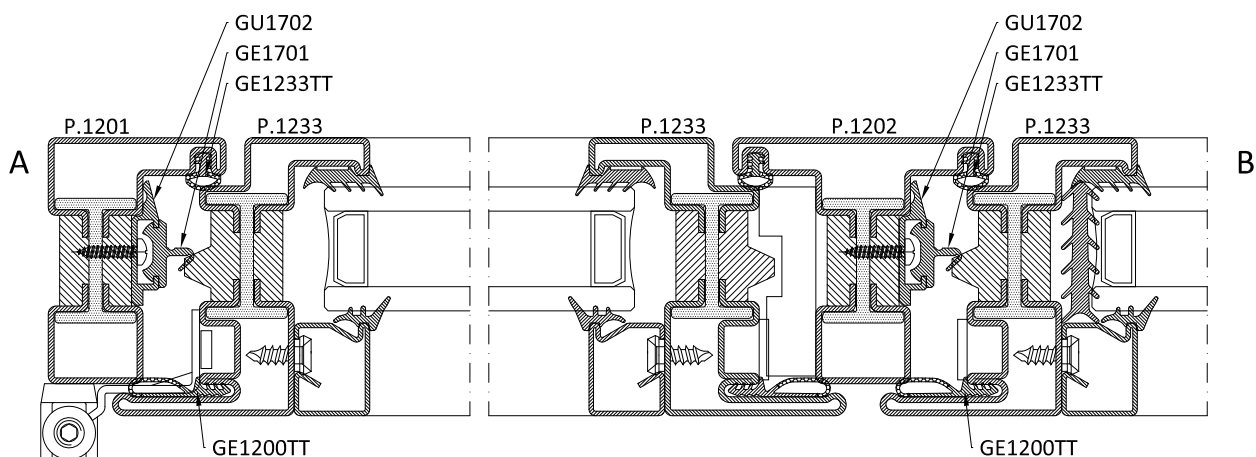
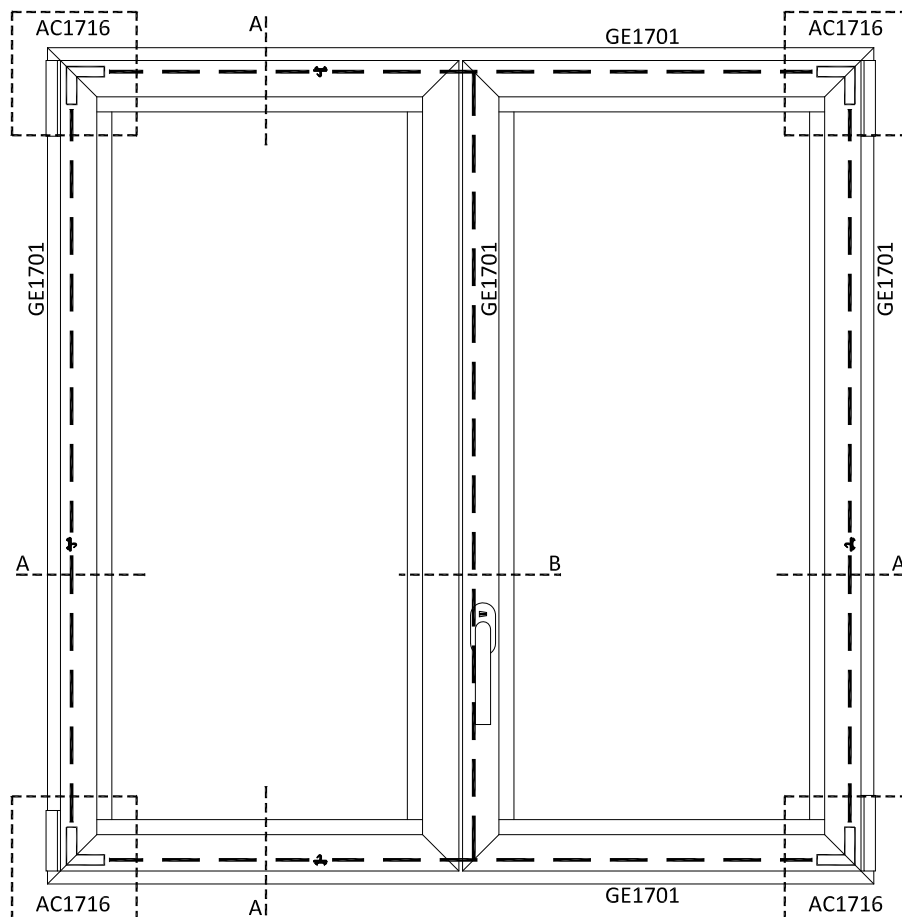
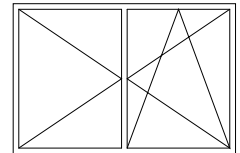

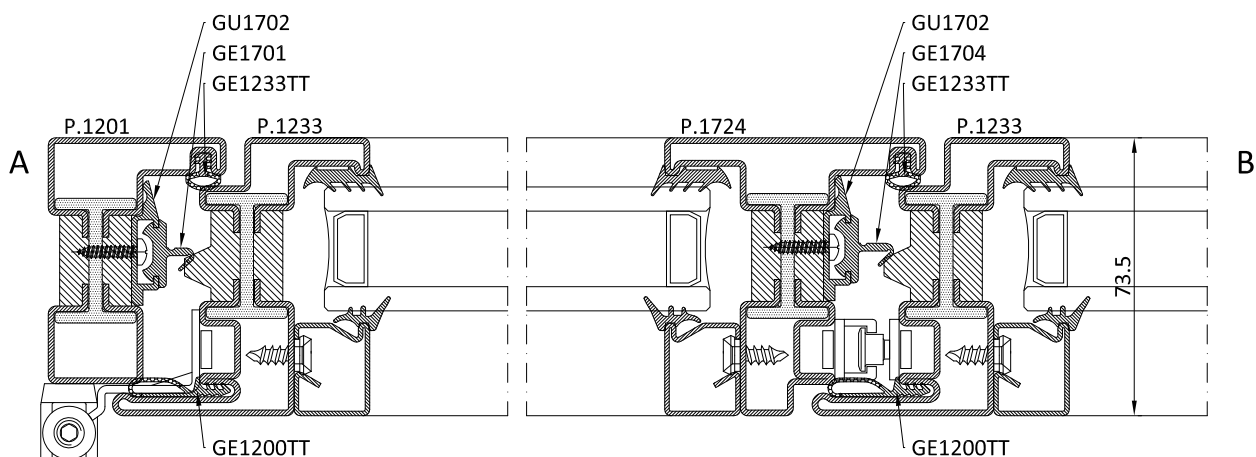
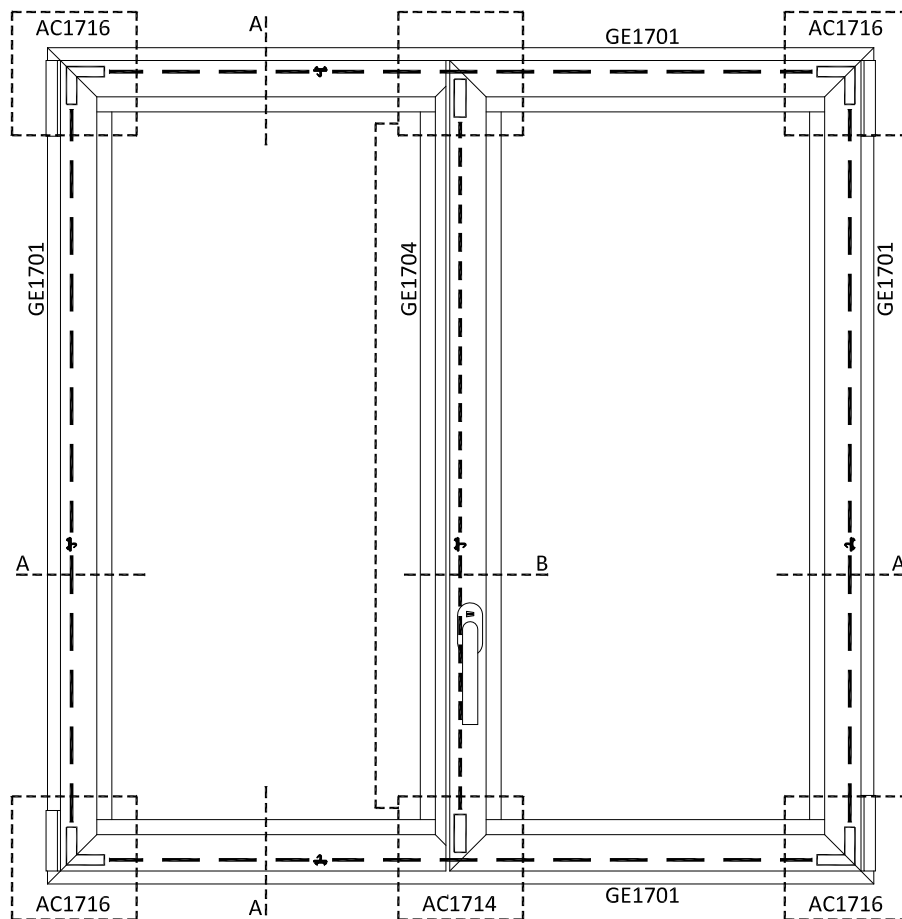
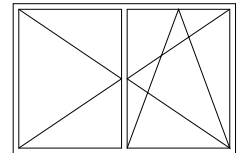

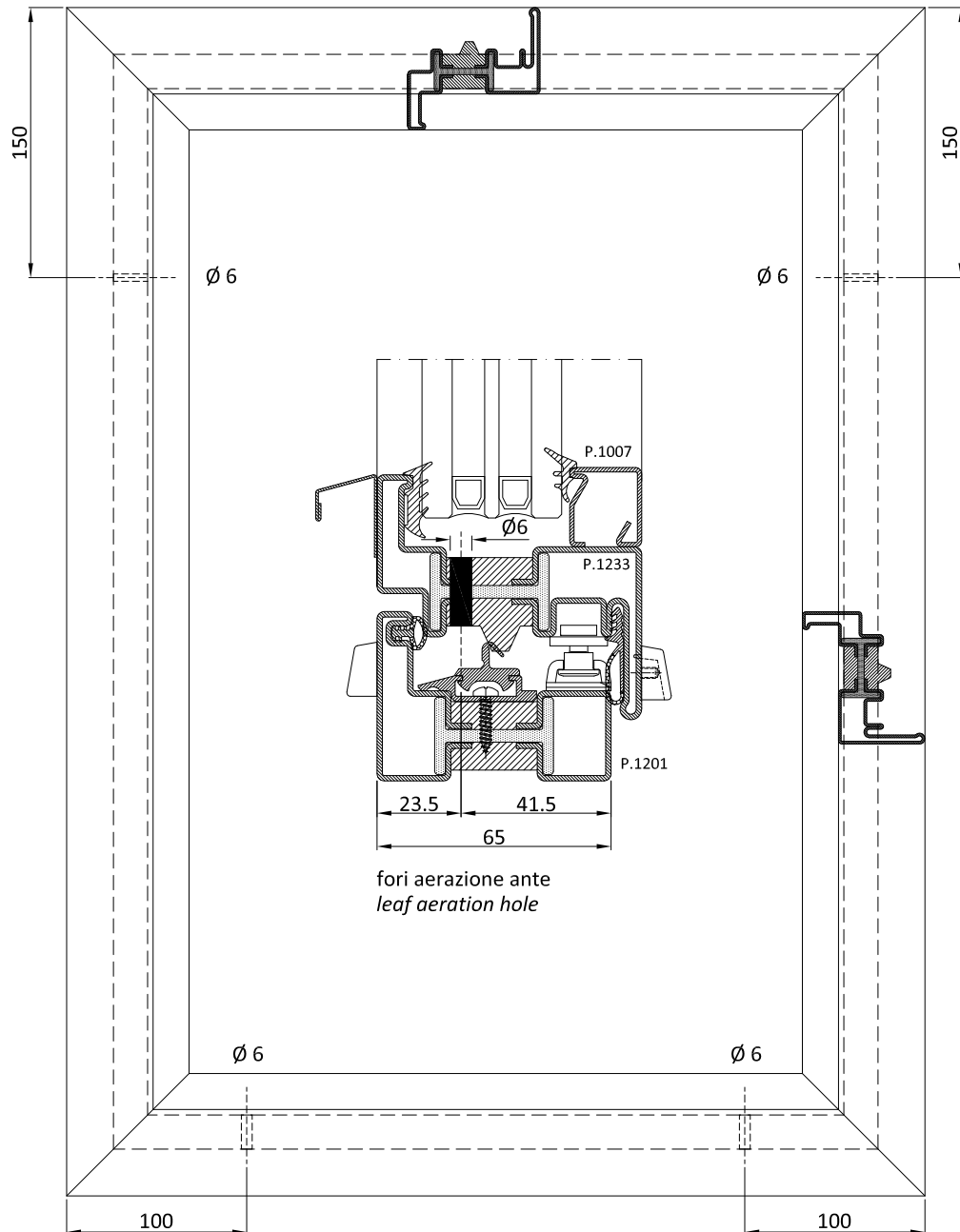
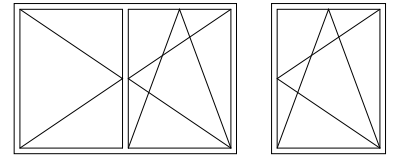

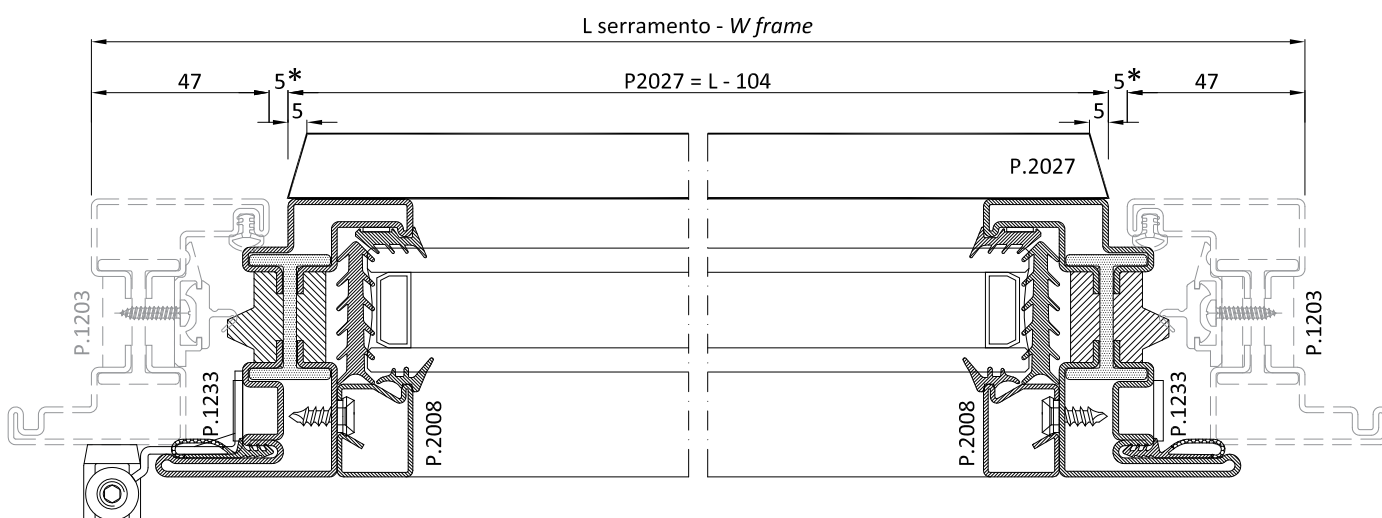
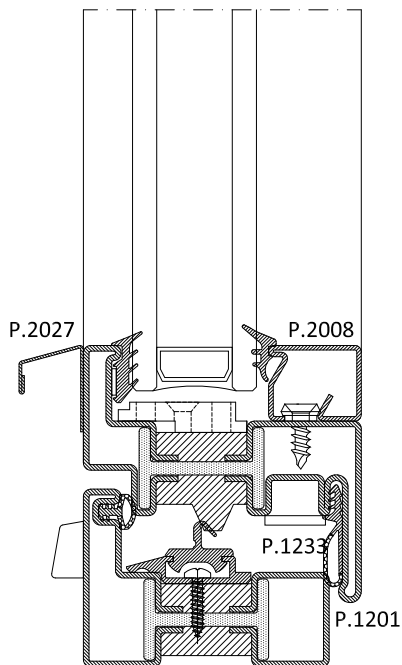
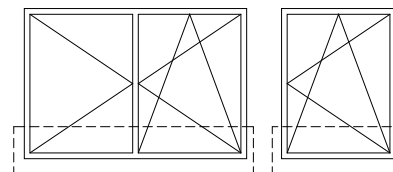

\* Vedi tabella 4.1.5  
\* See chart 4.1.5

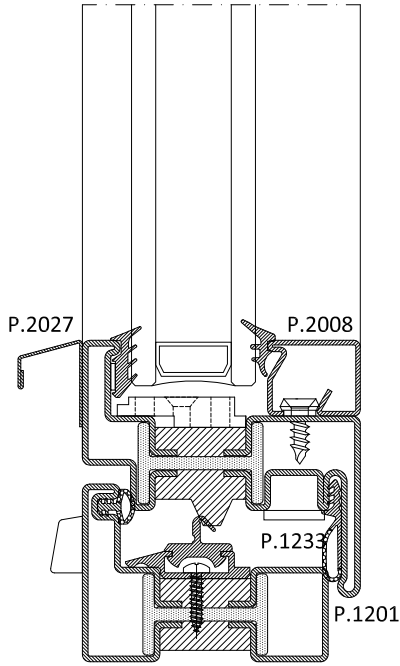
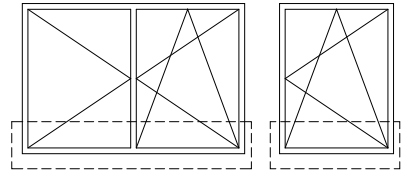

L serramento - W frame

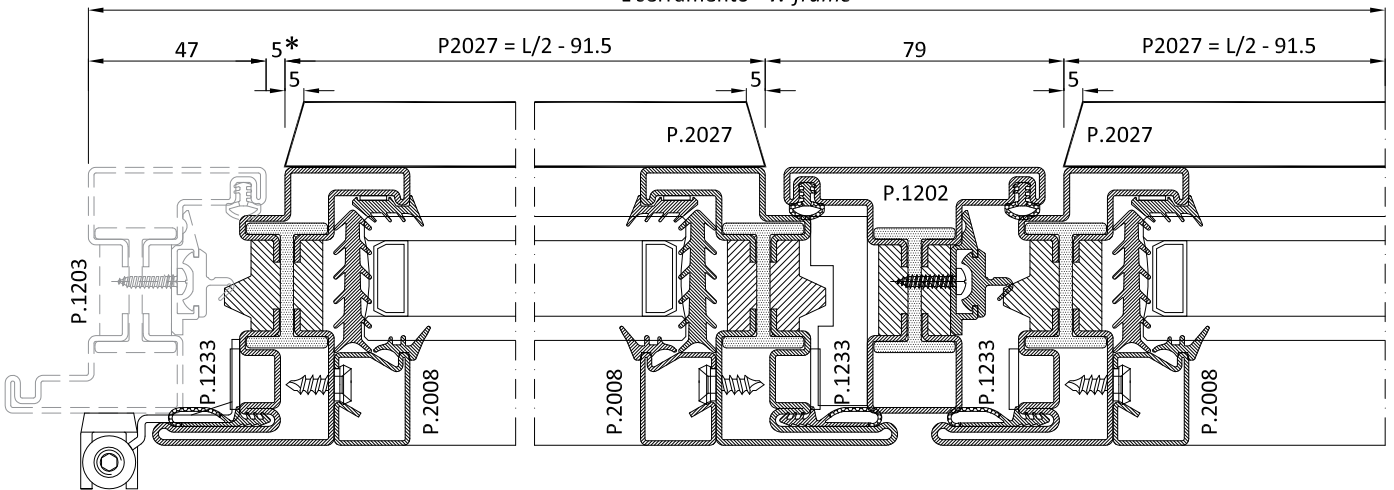

L serramento - W frame

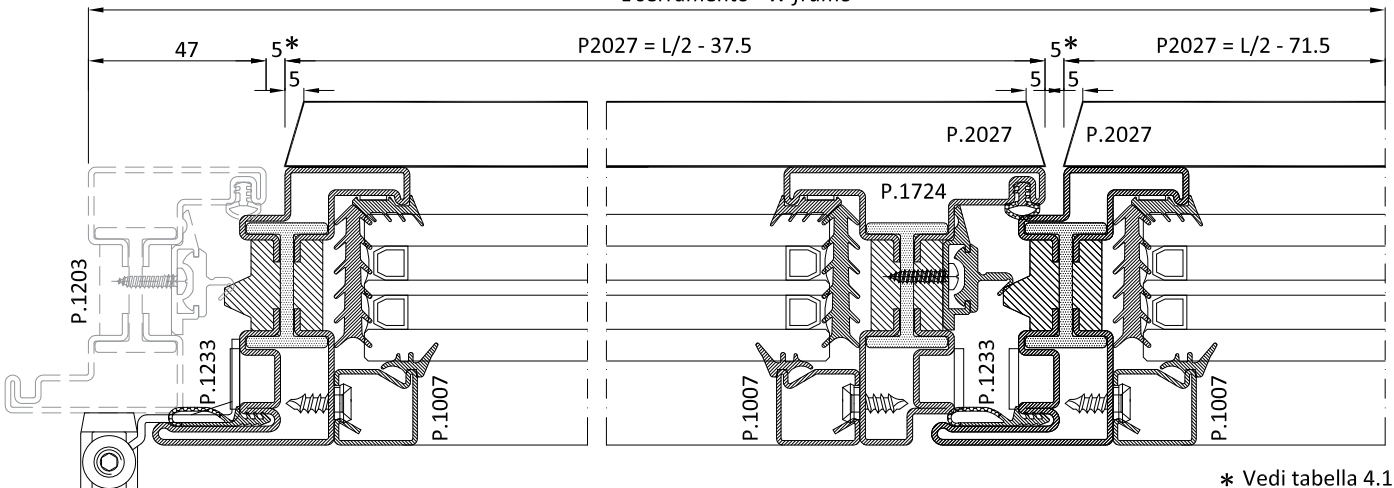

\* Vedi tabella 4.1.5  
\* See chart 4.1.5

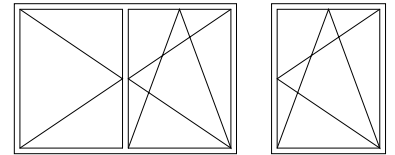

Easy	H altezza - height									
	661 860	861 1000	1001 1200	1201 1400	1401 1600	1601 1800	1801 2000	2001 2200	2201 2400	
L larghezza width	601-800	A1	B1	C1	D1	E1	F1	G1	H1	I1
	801-1000	-	B2	C2	D2	E2	F2	G2	H2	I2
	1001-1200	-	-	C3	D3	E3	F3	G3	H3	I3
	1201-1400	-	-	-	D4	E4	-	-	-	-

AGA271-5	AGA775	180 kg	Easy
AGE271-2-5-6	AGE775-6	150 kg	Easy
AGE281-2-5-6	AGE785-6	130 kg	Easy
AGE291-2-5-6	AGE795-6	130 kg	Easy
AG1273		80 kg	Easy
AG1278		80 kg	Easy

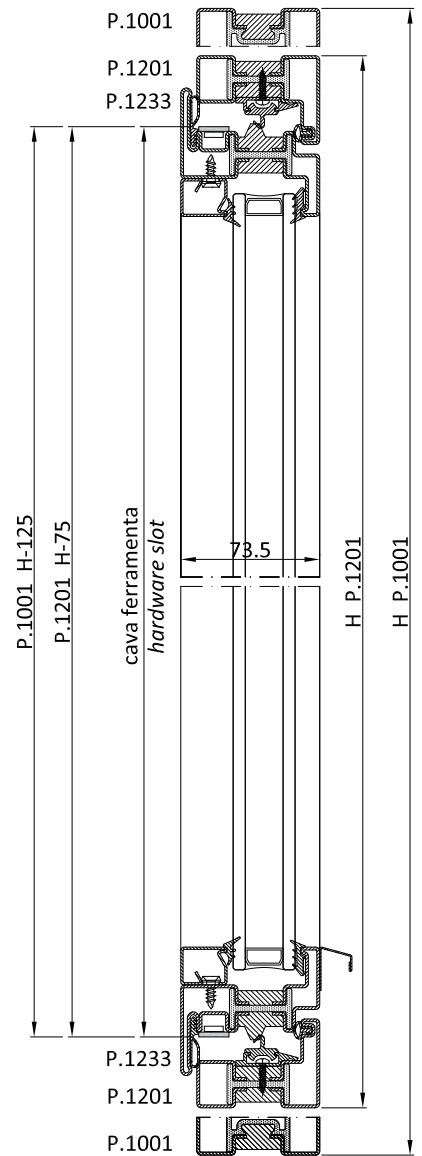
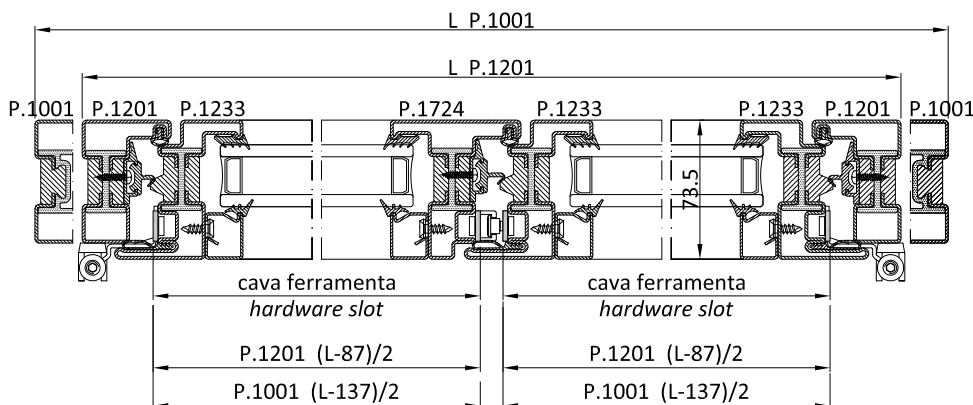
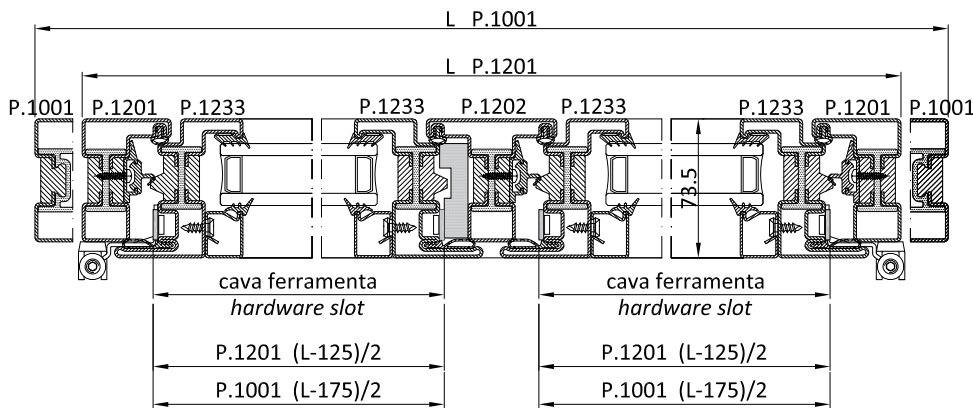
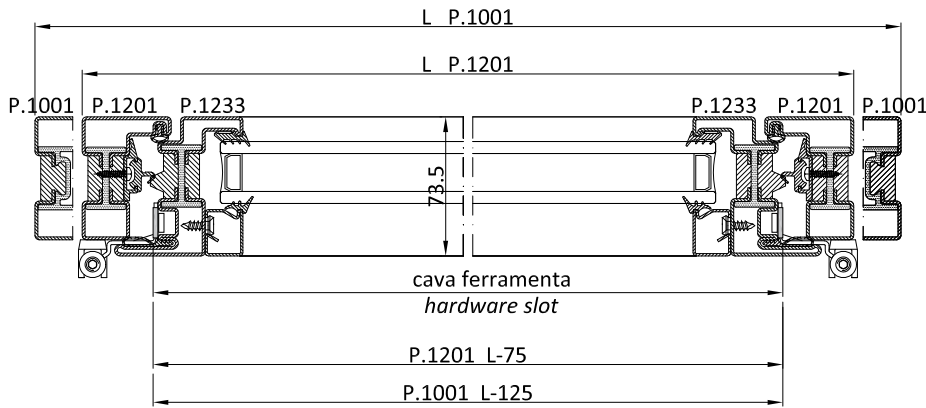

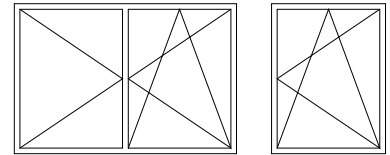

RC2		H altezza - height								
		661 860	861 1000	1001 1200	1201 1400	1401 1600	1601 1800	1801 2000	2001 2200	2201 2400
L larghezza width	601-800	A1	B1	C1	D1	E1	F1	G1	H1	I1
	801-1000	-	B2	C2	D2	E2	F2	G2	H2	I2
	1001-1200	-	-	C3	D3	E3	F3	G3	H3	I3
	1201-1400	-	-	-	D4	E4	-	-	-	-

AG1271-2-5-6                      150 kg    RC2  
 AG1281-2-5-6                      130 kg    RC2  
 AG1291-2-5-6                      130 kg    RC2

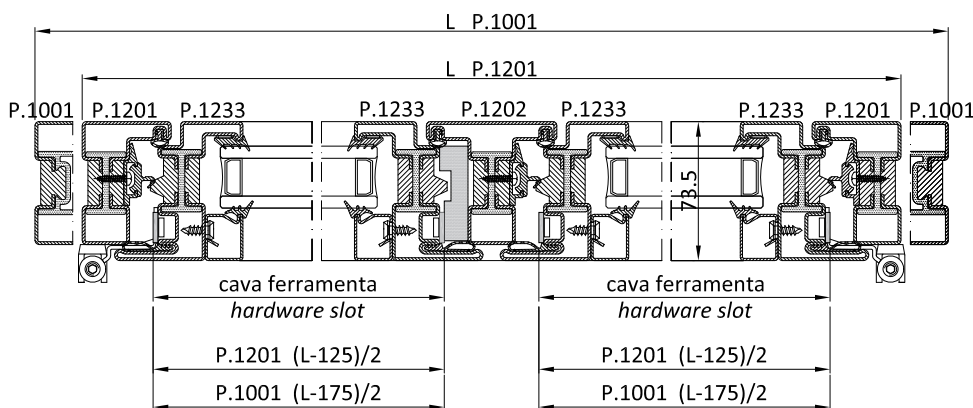
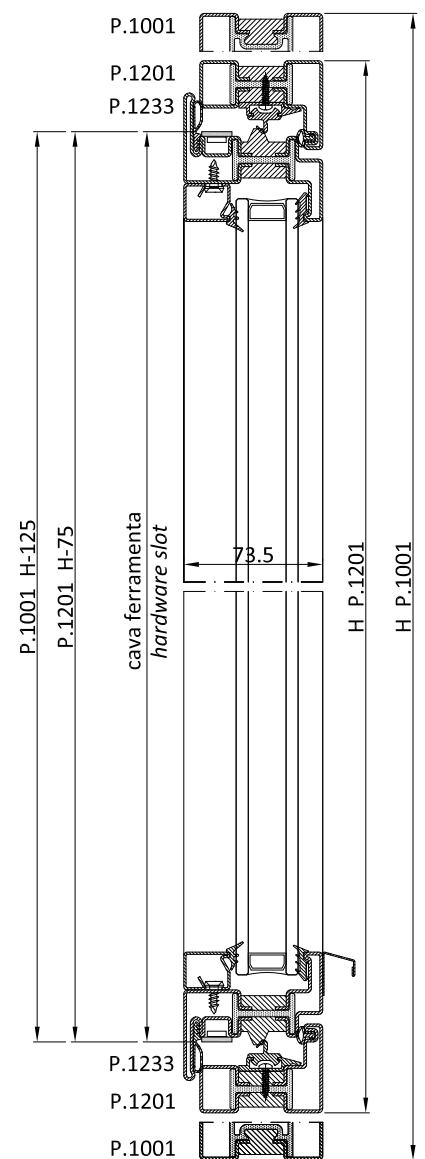
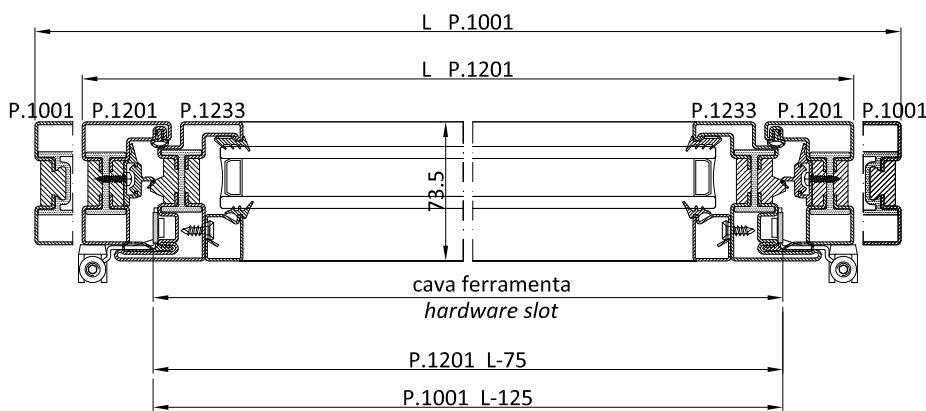

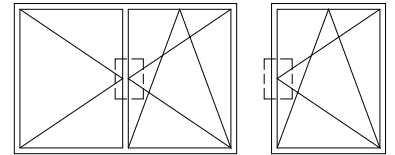

Fori per inserimento quadro comando e fissaggio maniglia / movimento DK  
Holes for inserting control panel and anchoring of handle / TT (tilt and turn) movement

Asola per inserimento meccanismo cremonese  
Slot for insertion of cremone mechanism

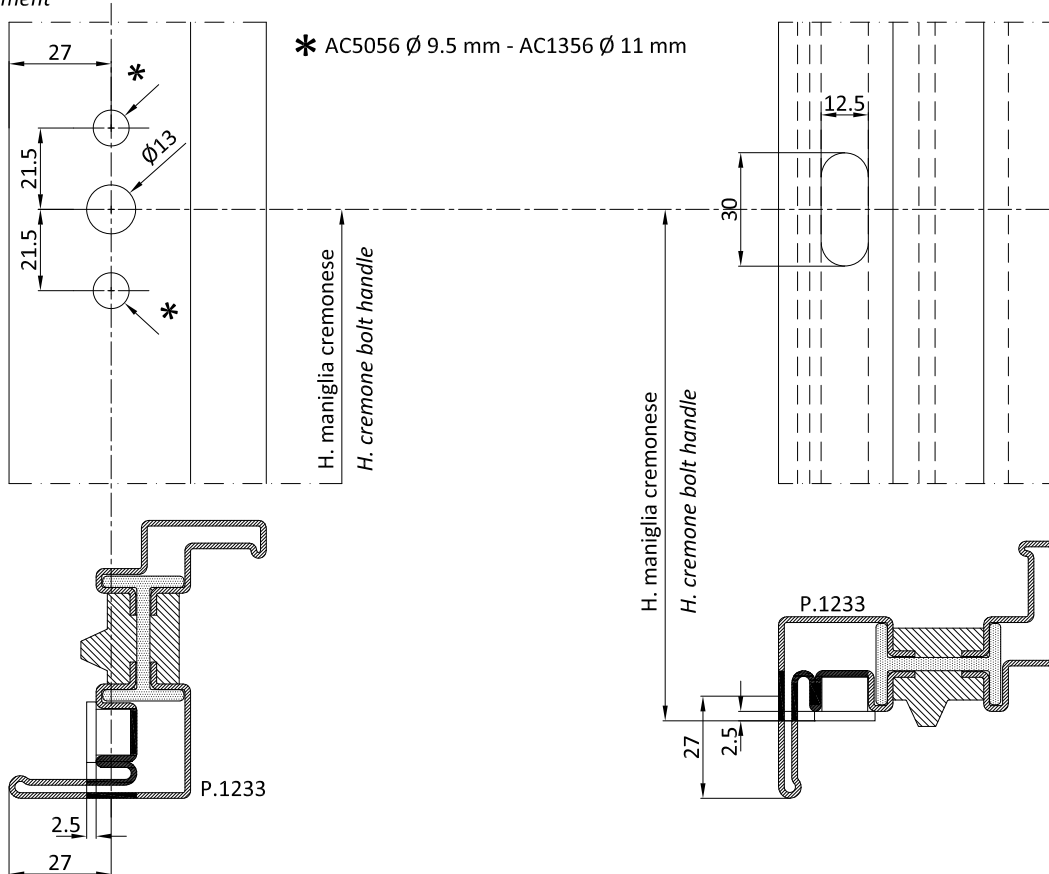

ALTEZZA MANIGLIA CREMONESE - CREMONE BOLT HANDLE HEIGHT			
Tipo Type	H cava ferramenta - H hardware slot Easy - RC2		
	H maniglia cremonese H cremone bolt handle		
Finestre Windows	Y	370 → 520 (No RC2)	H/2
	Z	521 → 660 (No RC2)	H/2
	A	661 → 860	H/2
	B	861 → 1000	H/2
	C	1001 → 1200	500
	D	1201 → 1400	500
	E	1401 → 1600	500
Porte - finestre French Windows	F	1601 → 1800	500
	G	1801 → 2000	1050
	H	2001 → 2200	1050
	I	2201 → 2400	1050
	J	2401 → 2600	1050
	K	2601 → 2800	1050
	L	2801 → 3000	1050



Easy peso massimo anta 150 kg  
maximum leaf weight 150 kg

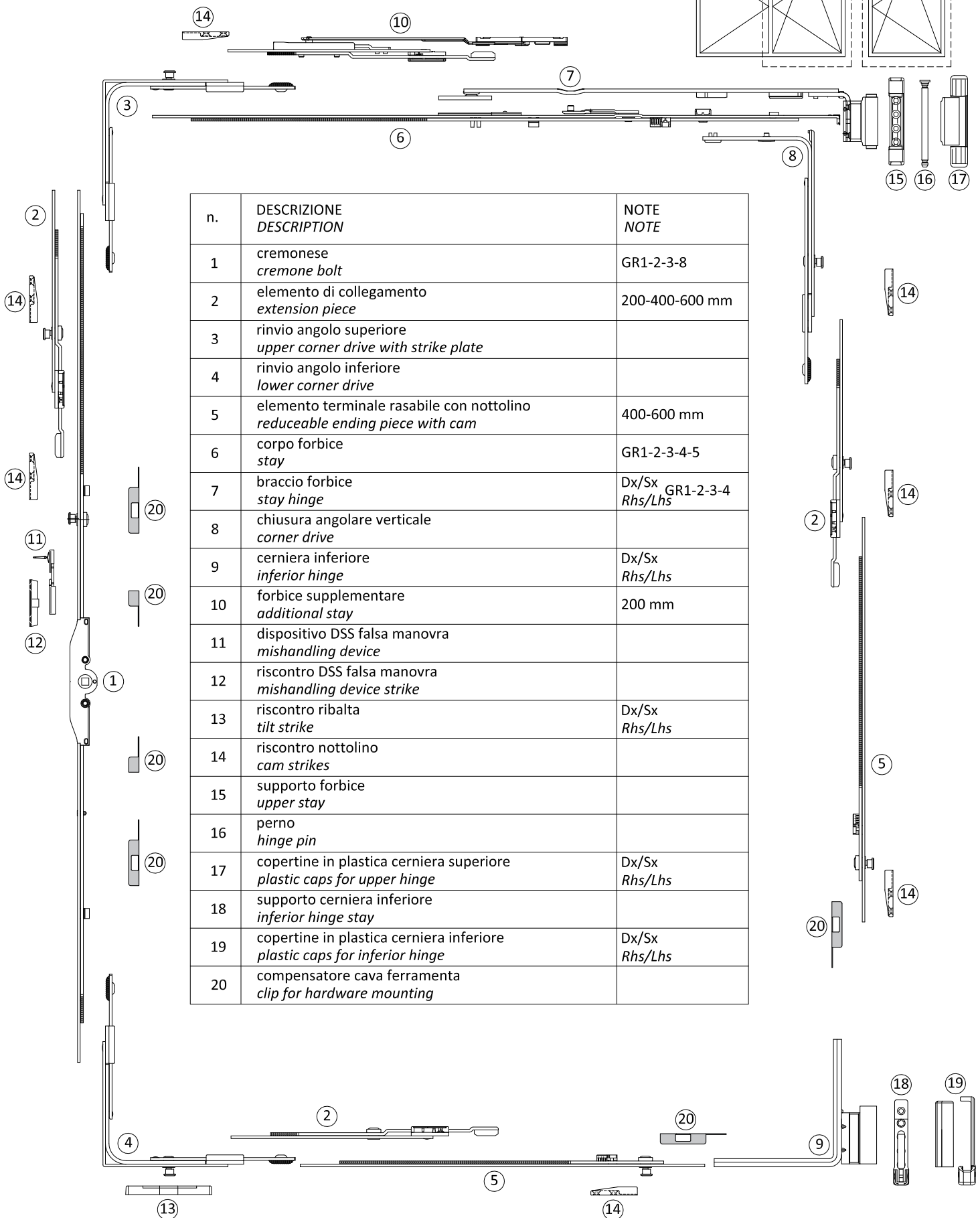
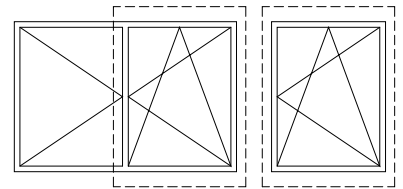

n.	DESCRIZIONE DESCRIPTION	NOTE NOTE
1	cremonese <i>cremone bolt</i>	GR1-2-3-8
2	elemento di collegamento <i>extension piece</i>	200-400-600 mm
3	rinvio angolo superiore <i>upper corner drive with strike plate</i>	
4	rinvio angolo inferiore <i>lower corner drive</i>	
5	elemento terminale rasabile con nottolino <i>reduceable ending piece with cam</i>	400-600 mm
6	corpo forbice <i>stay</i>	GR1-2-3-4-5
7	braccio forbice <i>stay hinge</i>	Dx/Sx GR1-2-3-4 Rhs/Lhs
8	chiusura angolare verticale <i>corner drive</i>	
9	cerniera inferiore <i>inferior hinge</i>	Dx/Sx Rhs/Lhs
10	forbice supplementare <i>additional stay</i>	200 mm
11	dispositivo DSS falsa manovra <i>mishandling device</i>	
12	riscontro DSS falsa manovra <i>mishandling device strike</i>	
13	riscontro ribalta <i>tilt strike</i>	Dx/Sx Rhs/Lhs
14	riscontro nottolino <i>cam strikes</i>	
15	supporto forbice <i>upper stay</i>	
16	perno <i>hinge pin</i>	
17	copertine in plastica cerniera superiore <i>plastic caps for upper hinge</i>	Dx/Sx Rhs/Lhs
18	supporto cerniera inferiore <i>inferior hinge stay</i>	
19	copertine in plastica cerniera inferiore <i>plastic caps for inferior hinge</i>	Dx/Sx Rhs/Lhs
20	compensatore cava ferramenta <i>clip for hardware mounting</i>	

Easy

peso massimo anta 150 kg  
maximum leaf weight 150 kg

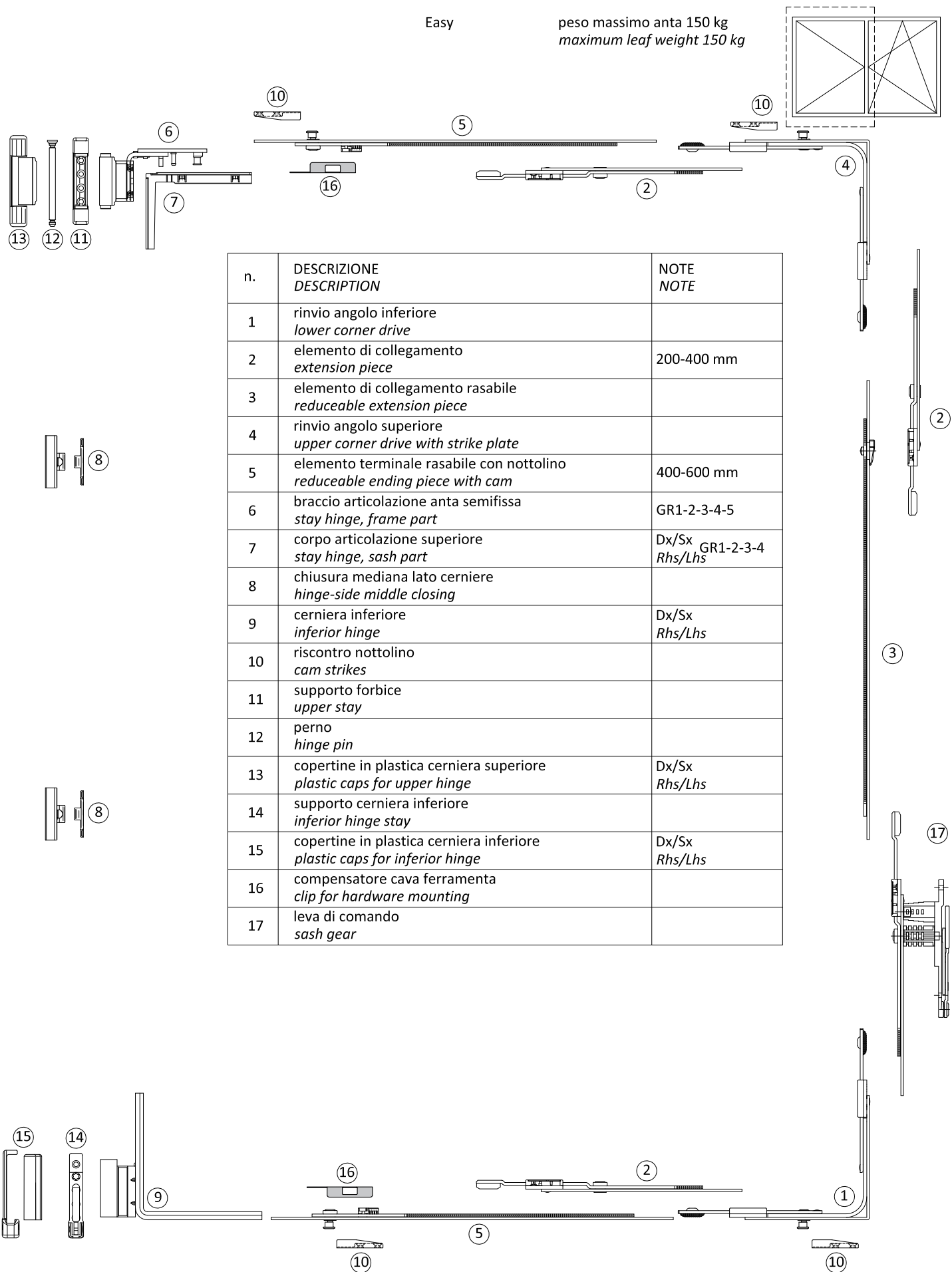

n.	DESCRIZIONE DESCRIPTION	NOTE NOTE
1	rinvio angolo inferiore lower corner drive	
2	elemento di collegamento extension piece	200-400 mm
3	elemento di collegamento rasabile reduceable extension piece	
4	rinvio angolo superiore upper corner drive with strike plate	
5	elemento terminale rasabile con nottolino reduceable ending piece with cam	400-600 mm
6	braccio articolazione anta semifissa stay hinge, frame part	GR1-2-3-4-5
7	corpo articolazione superiore stay hinge, sash part	Dx/Sx GR1-2-3-4 Rhs/Lhs
8	chiusura mediana lato cerniere hinge-side middle closing	
9	cerniera inferiore inferior hinge	Dx/Sx Rhs/Lhs
10	riscontro nottolino cam strikes	
11	supporto forbice upper stay	
12	perno hinge pin	
13	copertine in plastica cerniera superiore plastic caps for upper hinge	Dx/Sx Rhs/Lhs
14	supporto cerniera inferiore inferior hinge stay	
15	copertine in plastica cerniera inferiore plastic caps for inferior hinge	Dx/Sx Rhs/Lhs
16	compensatore cava ferramenta clip for hardware mounting	
17	leva di comando sash gear	

Easy

peso massimo anta 150 kg  
maximum leaf weight 150 kg

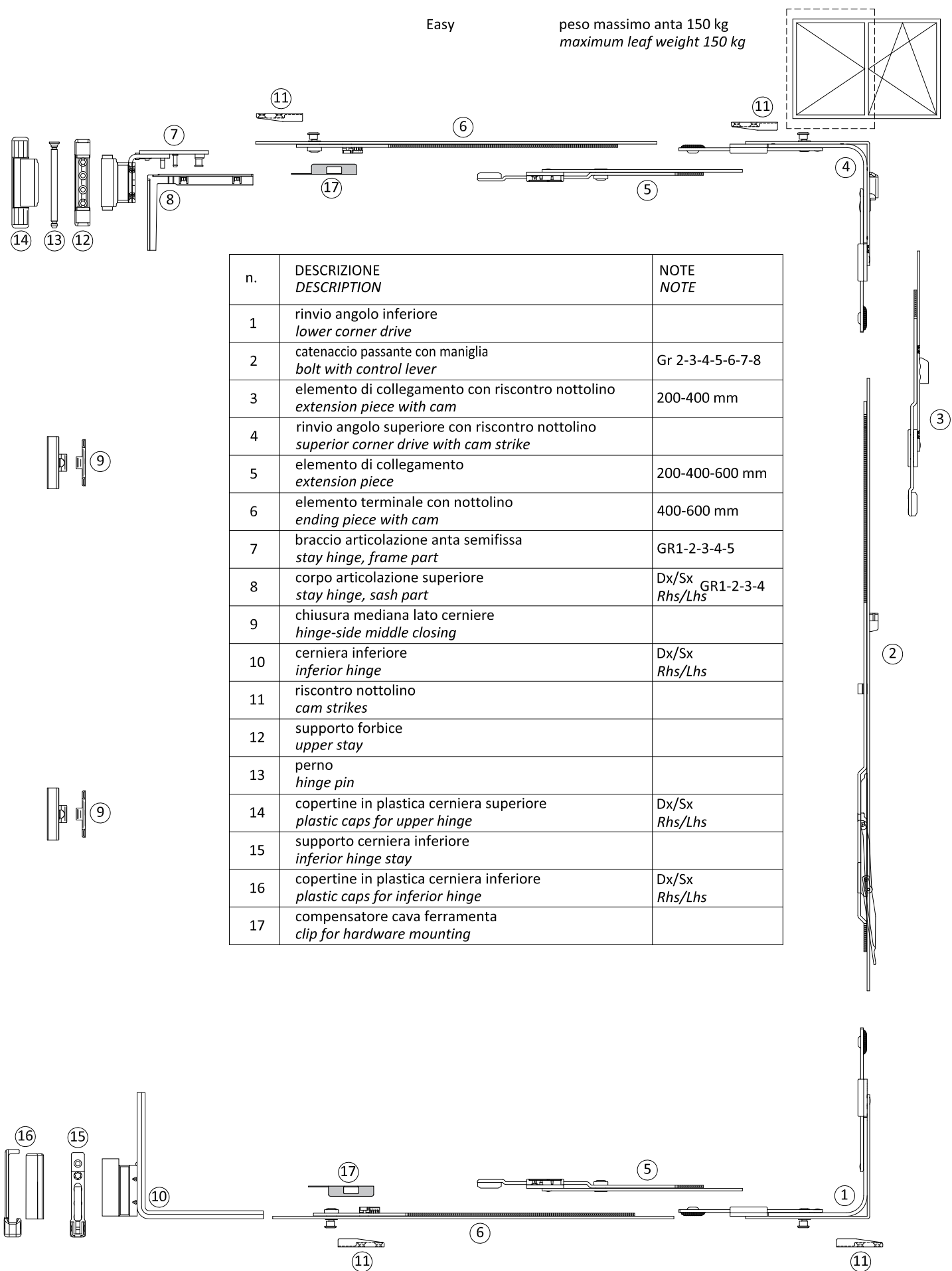

n.	DESCRIZIONE DESCRIPTION	NOTE NOTE
1	rinvio angolo inferiore lower corner drive	
2	catenaccio passante con maniglia bolt with control lever	Gr 2-3-4-5-6-7-8
3	elemento di collegamento con riscontro nottolino extension piece with cam	200-400 mm
4	rinvio angolo superiore con riscontro nottolino superior corner drive with cam strike	
5	elemento di collegamento extension piece	200-400-600 mm
6	elemento terminale con nottolino ending piece with cam	400-600 mm
7	braccio articolazione anta semifissa stay hinge, frame part	GR1-2-3-4-5
8	corpo articolazione superiore stay hinge, sash part	Dx/Sx GR1-2-3-4 Rhs/Lhs
9	chiusura mediana lato cerniere hinge-side middle closing	
10	cerniera inferiore inferior hinge	Dx/Sx Rhs/Lhs
11	riscontro nottolino cam strikes	
12	supporto forbice upper stay	
13	perno hinge pin	
14	copertine in plastica cerniera superiore plastic caps for upper hinge	Dx/Sx Rhs/Lhs
15	supporto cerniera inferiore inferior hinge stay	
16	copertine in plastica cerniera inferiore plastic caps for inferior hinge	Dx/Sx Rhs/Lhs
17	compensatore cava ferramenta clip for hardware mounting	

RC2

peso massimo anta 150 kg  
maximum leaf weight 150 kg

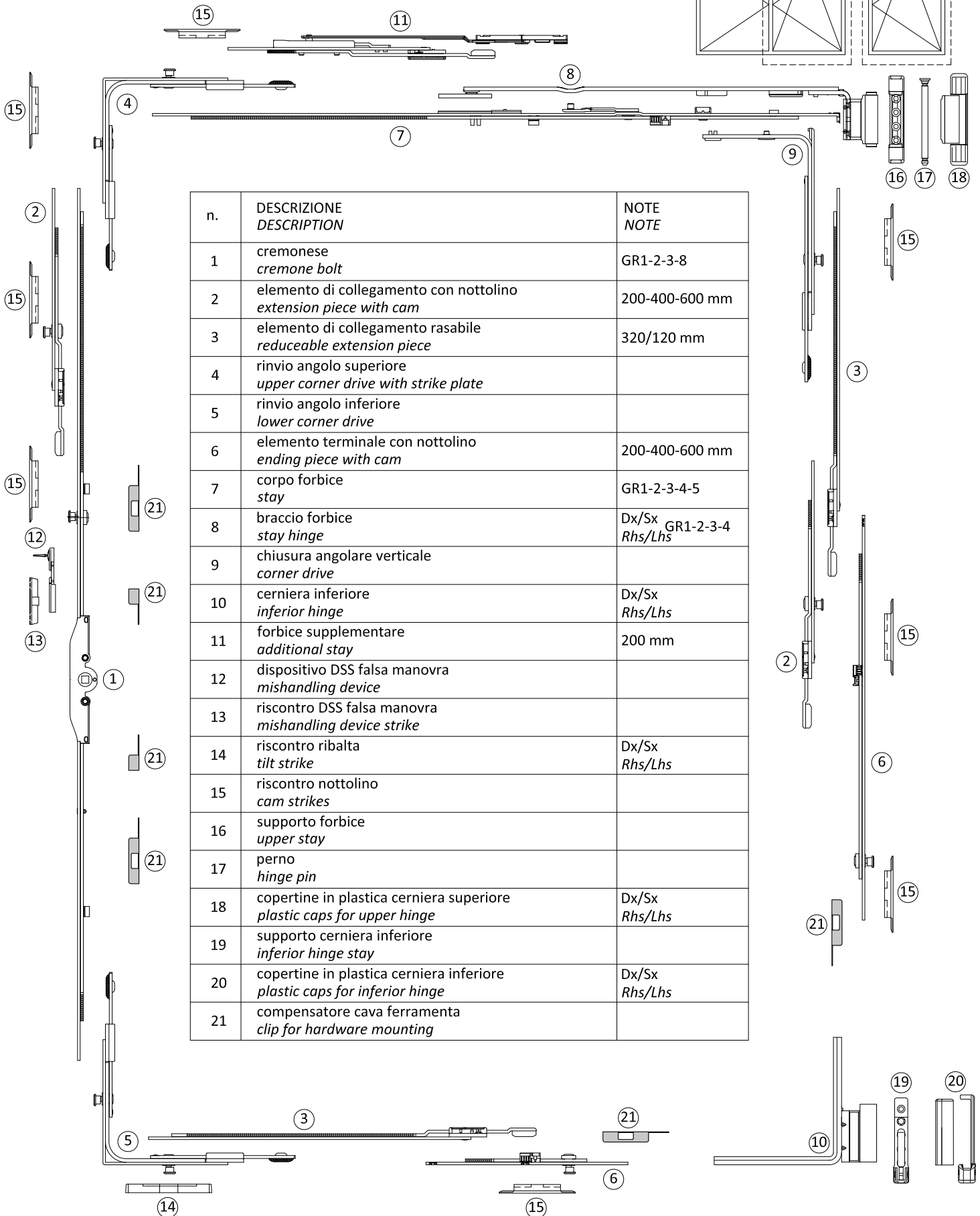
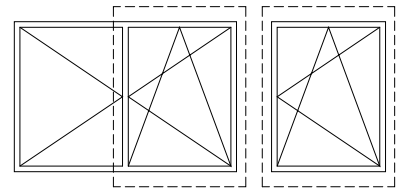

n.	DESCRIZIONE DESCRIPTION	NOTE NOTE
1	cremonese cremone bolt	GR1-2-3-8
2	elemento di collegamento con nottolino extension piece with cam	200-400-600 mm
3	elemento di collegamento rasabile reduceable extension piece	320/120 mm
4	rinvio angolo superiore upper corner drive with strike plate	
5	rinvio angolo inferiore lower corner drive	
6	elemento terminale con nottolino ending piece with cam	200-400-600 mm
7	corpo forbice stay	GR1-2-3-4-5
8	braccio forbice stay hinge	Dx/Sx GR1-2-3-4 Rhs/Lhs
9	chiusura angolare verticale corner drive	
10	cerniera inferiore inferior hinge	Dx/Sx Rhs/Lhs
11	forbice supplementare additional stay	200 mm
12	dispositivo DSS falsa manovra mishandling device	
13	riscontro DSS falsa manovra mishandling device strike	
14	riscontro ribalta tilt strike	Dx/Sx Rhs/Lhs
15	riscontro nottolino cam strikes	
16	supporto forbice upper stay	
17	perno hinge pin	
18	copertine in plastica cerniera superiore plastic caps for upper hinge	Dx/Sx Rhs/Lhs
19	supporto cerniera inferiore inferior hinge stay	
20	copertine in plastica cerniera inferiore plastic caps for inferior hinge	Dx/Sx Rhs/Lhs
21	compensatore cava ferramenta clip for hardware mounting	



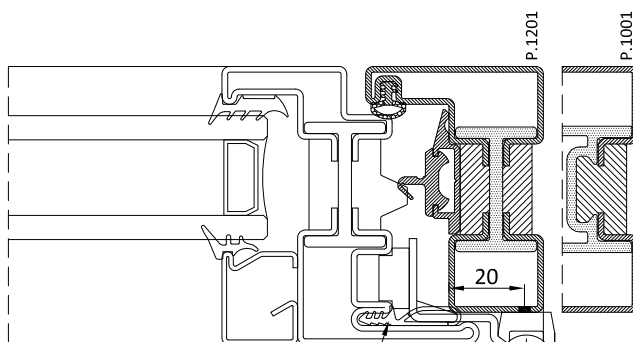
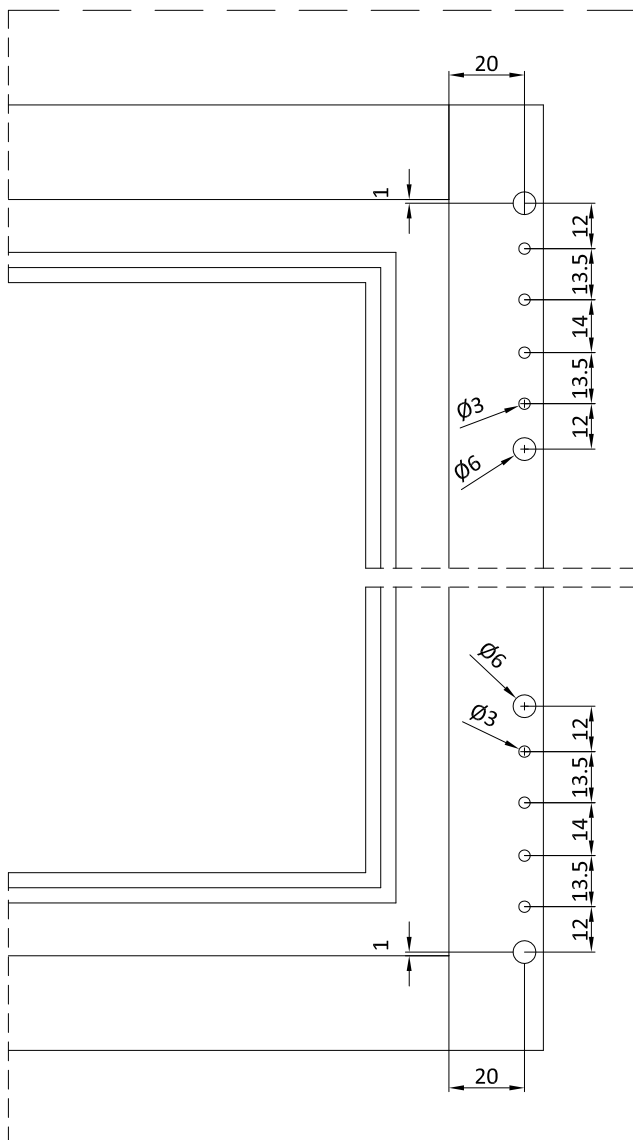
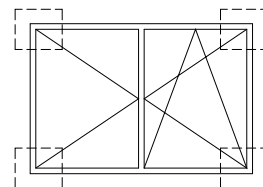

GE1200TT - tagliare la guarnizione dove interseca le cerniere  
GE1200TT - cut the gasket where the hinges cross

Fori eseguibili con maschera ATG271  
Holes to be done with ATG271



Easy peso massimo anta 130 kg  
maximum leaf weight 130 kg

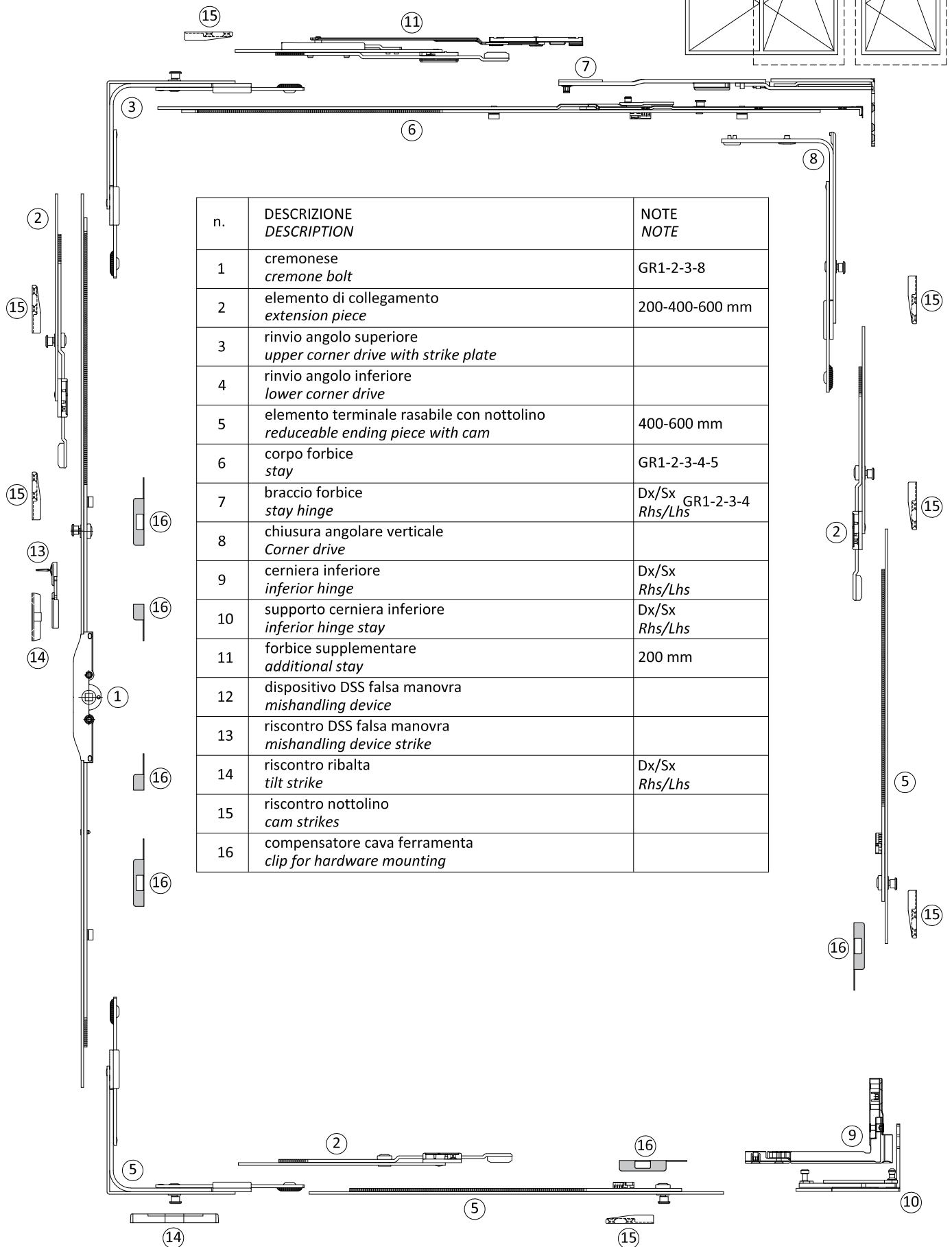
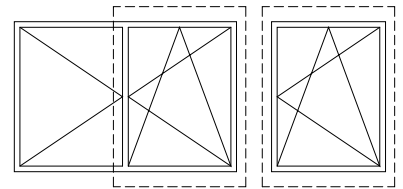

Easy

peso massimo anta 130 kg  
maximum leaf weight 130 kg

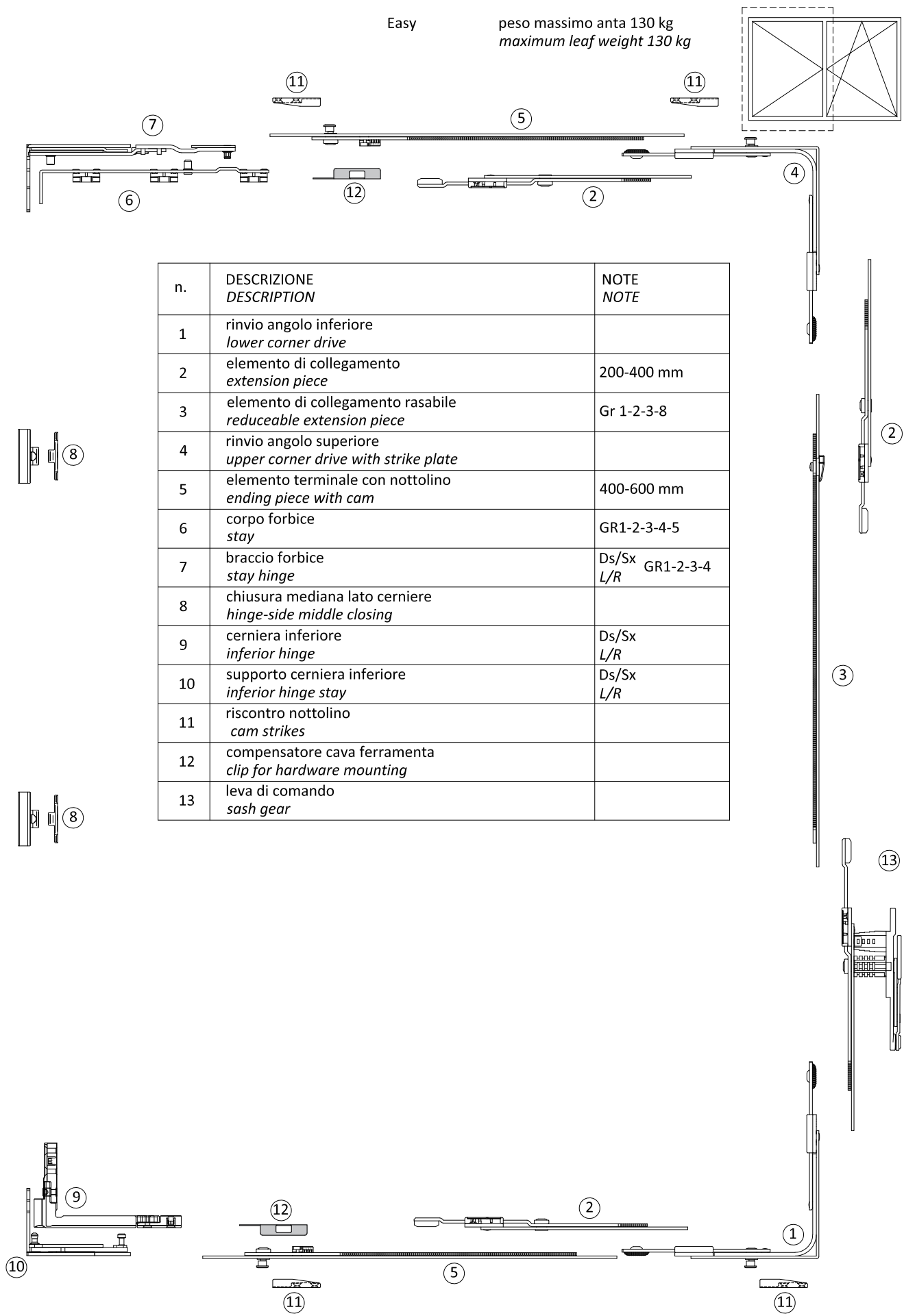

n.	DESCRIZIONE DESCRIPTION	NOTE NOTE
1	rinvio angolo inferiore lower corner drive	
2	elemento di collegamento extension piece	200-400 mm
3	elemento di collegamento rasabile reduceable extension piece	Gr 1-2-3-8
4	rinvio angolo superiore upper corner drive with strike plate	
5	elemento terminale con nottolino ending piece with cam	400-600 mm
6	corpo forbice stay	GR1-2-3-4-5
7	braccio forbice stay hinge	Ds/Sx L/R GR1-2-3-4
8	chiusura mediana lato cerniere hinge-side middle closing	
9	cerniera inferiore inferior hinge	Ds/Sx L/R
10	supporto cerniera inferiore inferior hinge stay	Ds/Sx L/R
11	riscontro nottolino cam strikes	
12	compensatore cava ferramenta clip for hardware mounting	
13	leva di comando sash gear	



Easy

peso massimo anta 130 kg  
maximum leaf weight 130 kg

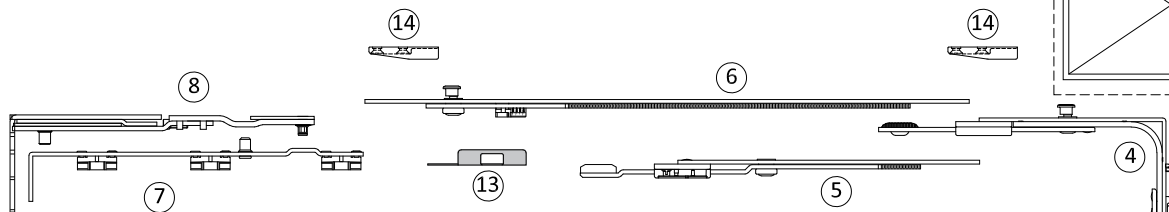
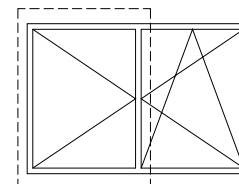

n.	DESCRIZIONE DESCRIPTION	NOTE NOTE
1	rinvio angolo inferiore lower corner drive	
2	catenaccio passante con maniglia bolt with control lever	Gr 2-3-4-5-6-7-8
3	elemento di collegamento con riscontro nottolino extension piece with cam	200-400 mm
4	rinvio angolo superiore con riscontro nottolino superior corner drive with cam strike	
5	elemento di collegamento extension piece	200-400-600 mm
6	elemento terminale con nottolino ending piece with cam	400-600 mm
7	corpo forbice stay	GR1-2-3-4-5
8	braccio forbice stay hinge	Ds/Sx L/R GR1-2-3-4
9	chiusura mediana lato cerniere hinge-side middle closing	
10	cerniera inferiore inferior hinge	Ds/Sx L/R
11	supporto cerniera inferiore inferior hinge stay	Ds/Sx L/R
12	riscontro nottolino cam strikes	
13	compensatore cava ferramenta clip for hardware mounting	

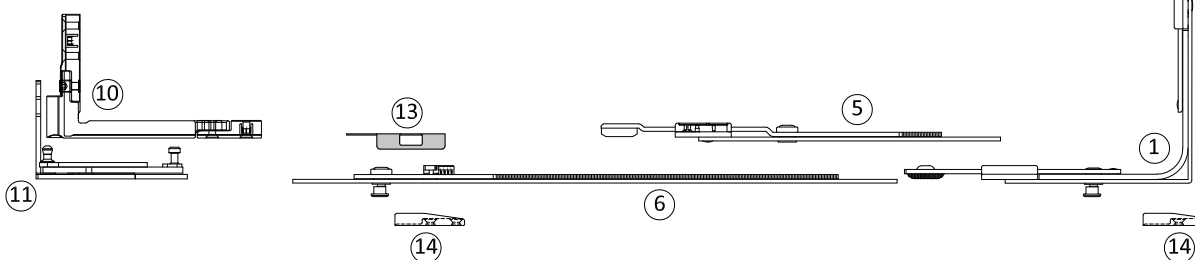
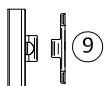
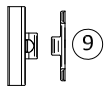

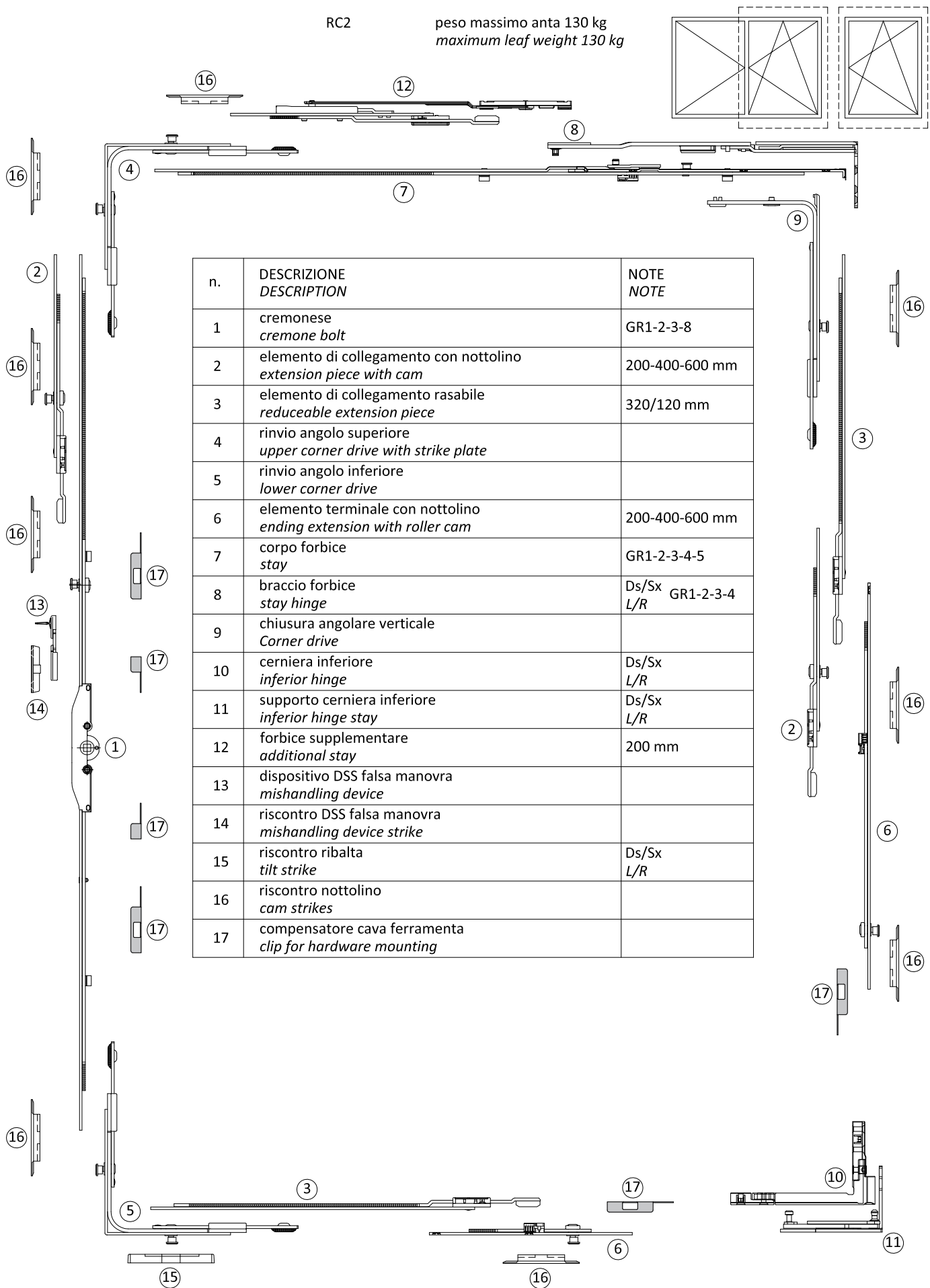

RC2

peso massimo anta 130 kg  
maximum leaf weight 130 kg

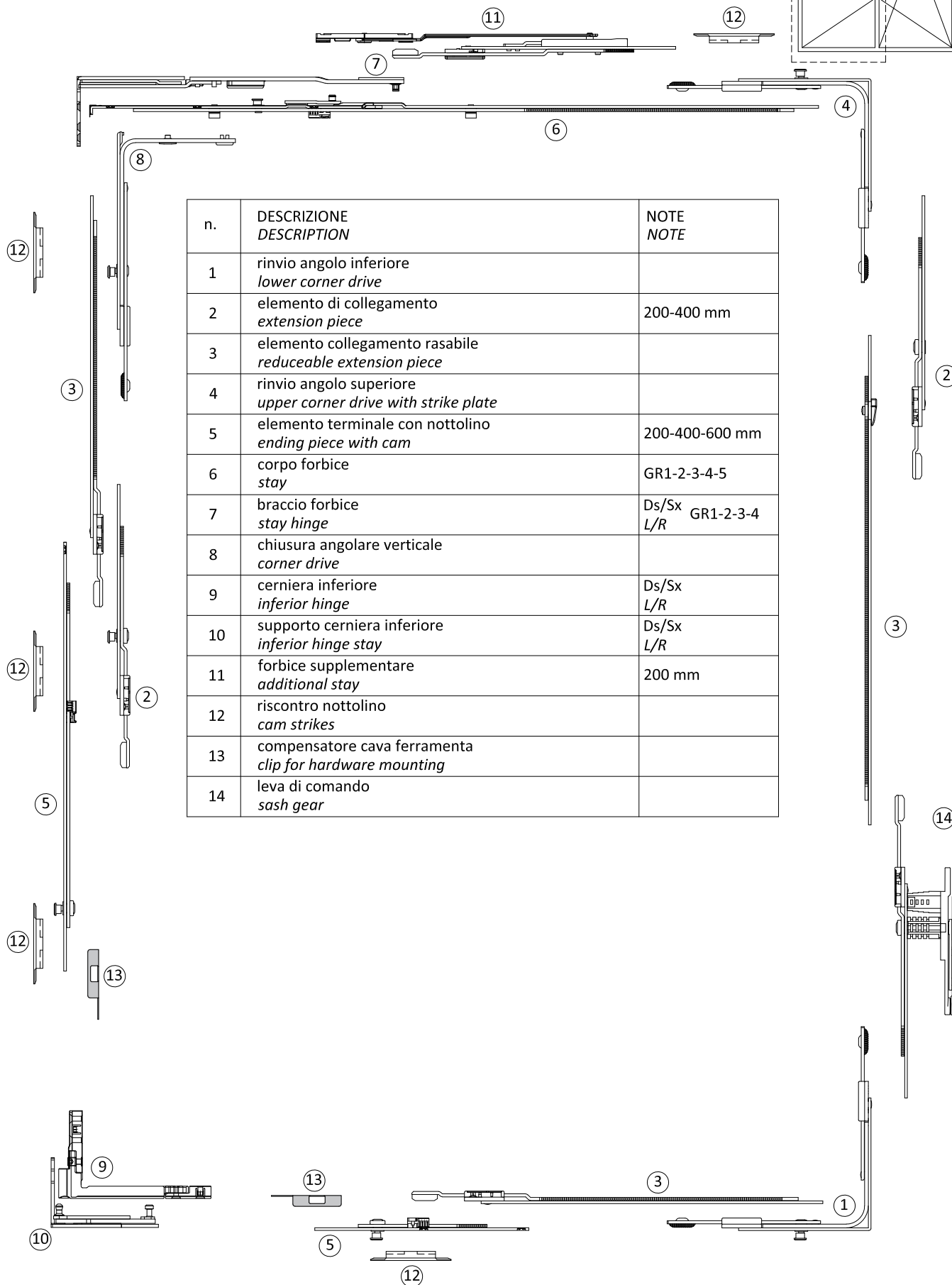
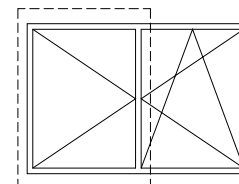

n.	DESCRIZIONE DESCRIPTION	NOTE NOTE
1	rinvio angolo inferiore lower corner drive	
2	elemento di collegamento extension piece	200-400 mm
3	elemento collegamento rasabile reduceable extension piece	
4	rinvio angolo superiore upper corner drive with strike plate	
5	elemento terminale con nottolino ending piece with cam	200-400-600 mm
6	corpo forbice stay	GR1-2-3-4-5
7	braccio forbice stay hinge	Ds/Sx L/R GR1-2-3-4
8	chiusura angolare verticale corner drive	
9	cerniera inferiore inferior hinge	Ds/Sx L/R
10	supporto cerniera inferiore inferior hinge stay	Ds/Sx L/R
11	forbice supplementare additional stay	200 mm
12	riscontro nottolino cam strikes	
13	compensatore cava ferramenta clip for hardware mounting	
14	leva di comando sash gear	

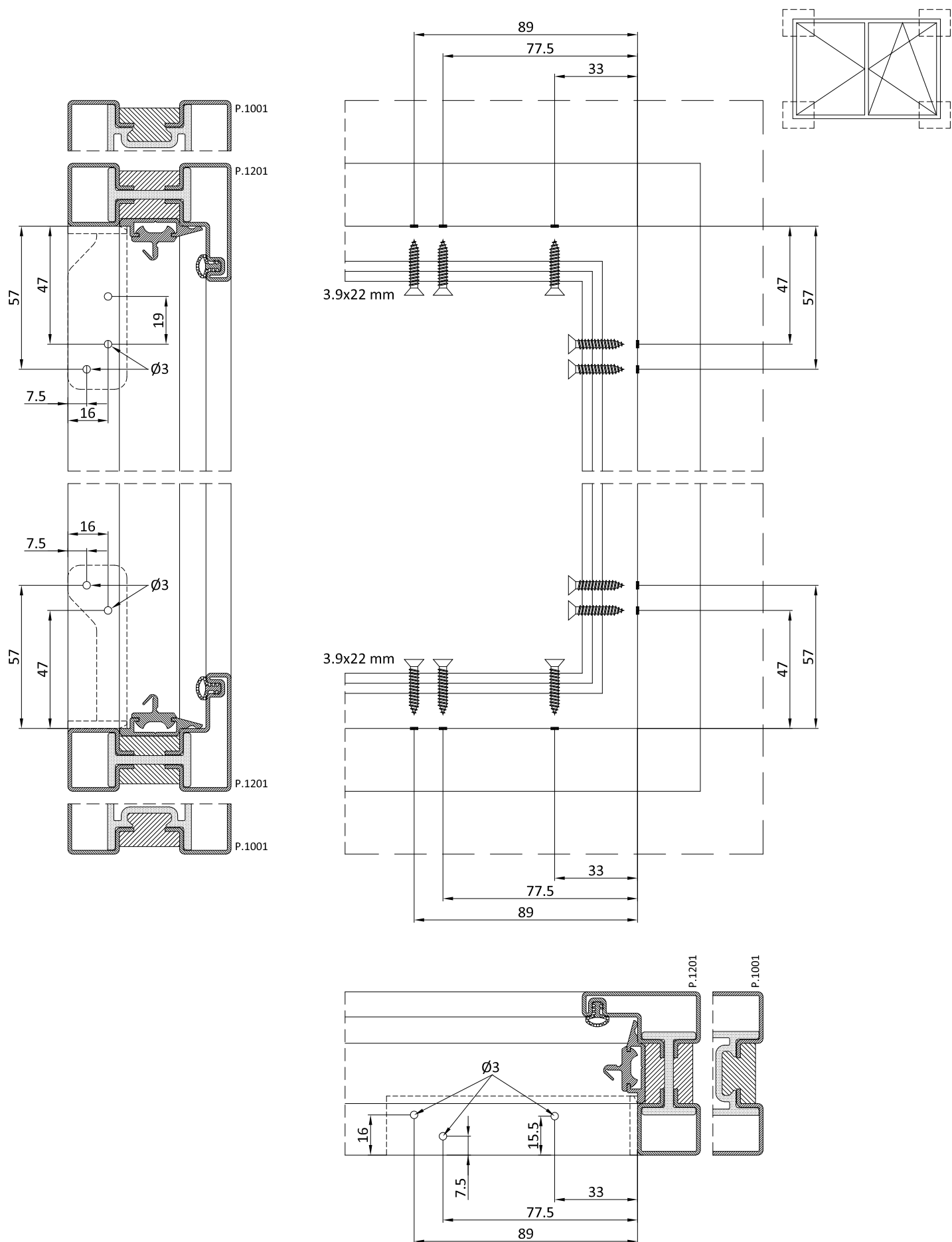

Fori eseguibili con maschera ATG281  
Holes to be done with ATG281



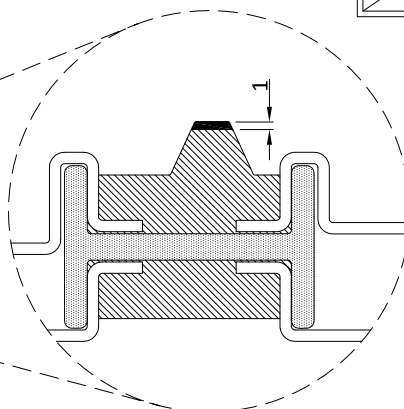
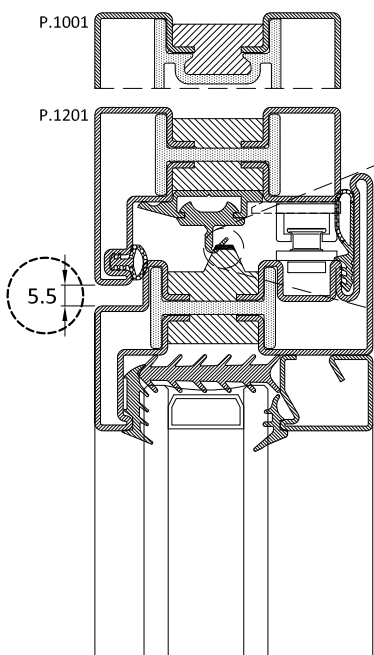
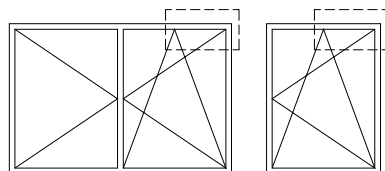

Larghezza cava ferramenta Width hardware slot [mm]	X [mm]
600 → 800	200
801 → 1400	280

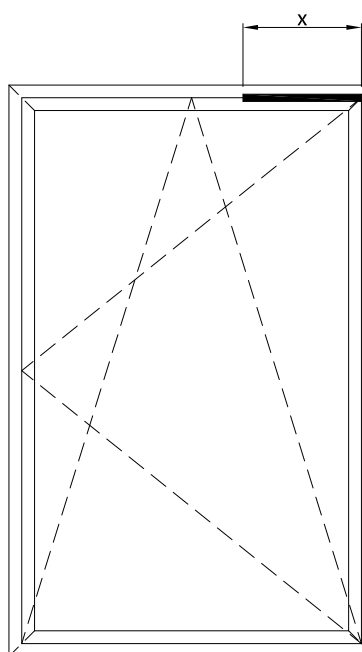
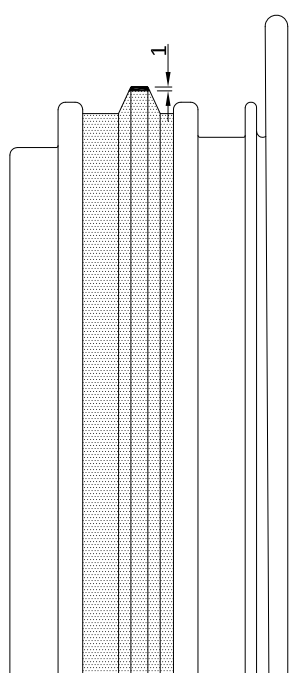
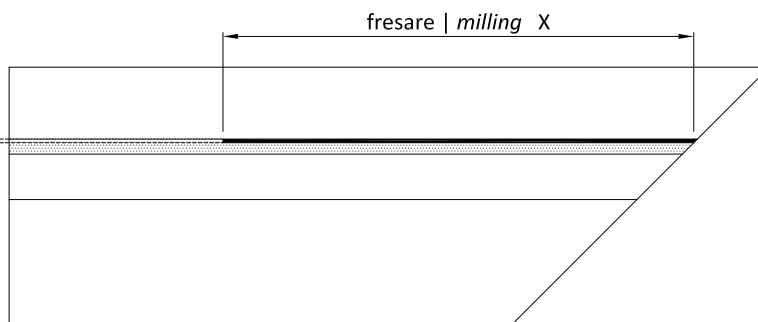
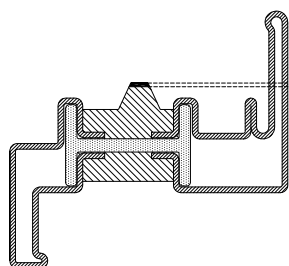

Easy peso massimo anta 130 kg  
maximum leaf weight 130 kg

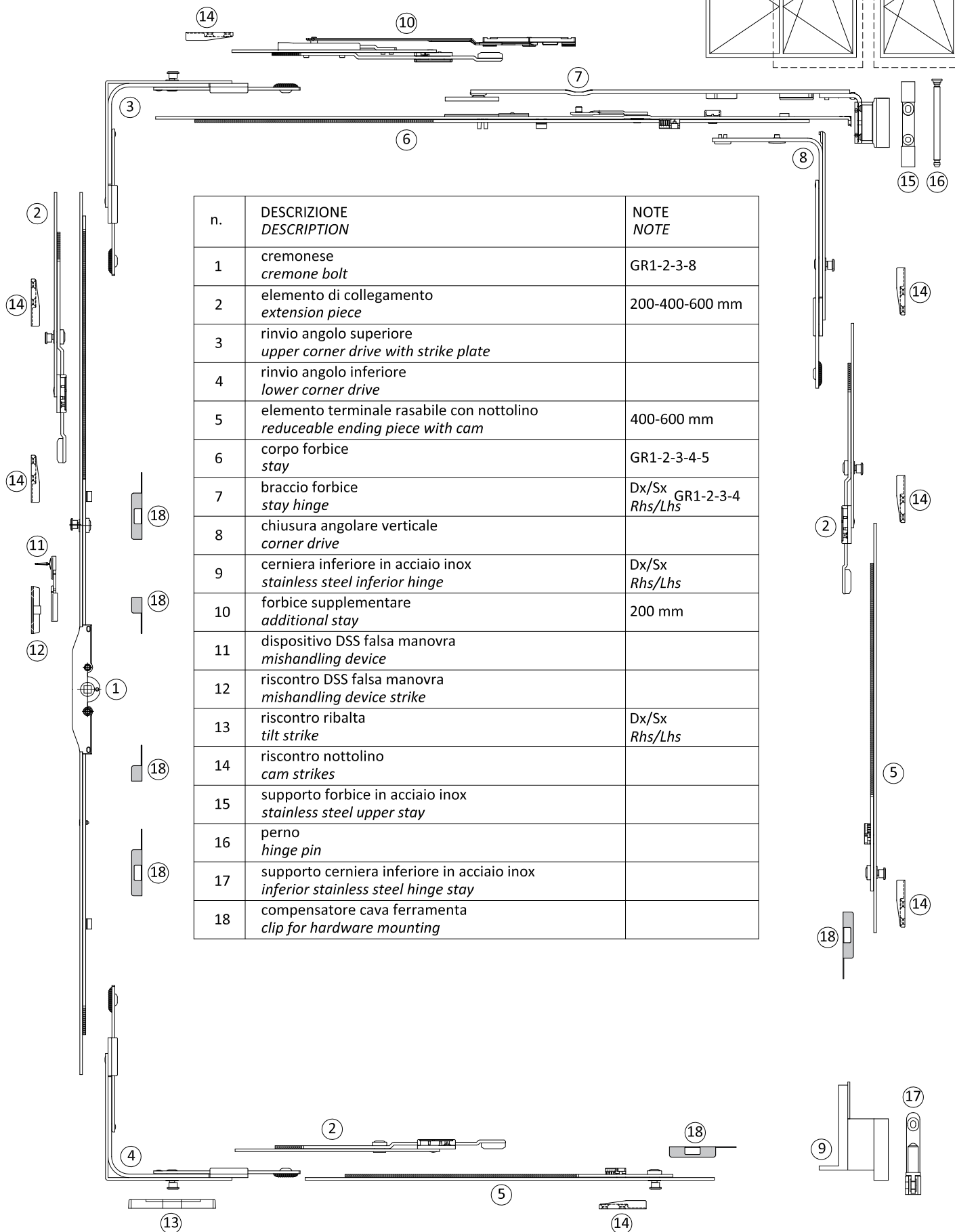
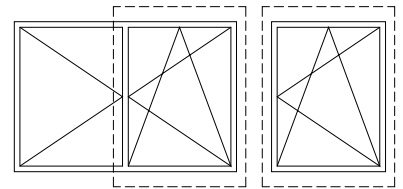

n.	DESCRIZIONE DESCRIPTION	NOTE NOTE
1	cremonese cremone bolt	GR1-2-3-8
2	elemento di collegamento extension piece	200-400-600 mm
3	rinvio angolo superiore upper corner drive with strike plate	
4	rinvio angolo inferiore lower corner drive	
5	elemento terminale rasabile con nottolino reduceable ending piece with cam	400-600 mm
6	corpo forbice stay	GR1-2-3-4-5
7	braccio forbice stay hinge	Dx/Sx GR1-2-3-4 Rhs/Lhs
8	chiusura angolare verticale corner drive	
9	cerniera inferiore in acciaio inox stainless steel inferior hinge	Dx/Sx Rhs/Lhs
10	forbice supplementare additional stay	200 mm
11	dispositivo DSS falsa manovra mishandling device	
12	riscontro DSS falsa manovra mishandling device strike	
13	riscontro ribalta tilt strike	Dx/Sx Rhs/Lhs
14	riscontro nottolino cam strikes	
15	supporto forbice in acciaio inox stainless steel upper stay	
16	perno hinge pin	
17	supporto cerniera inferiore in acciaio inox inferior stainless steel hinge stay	
18	compensatore cava ferramenta clip for hardware mounting	

Easy

peso massimo anta 130 kg  
maximum leaf weight 130 kg

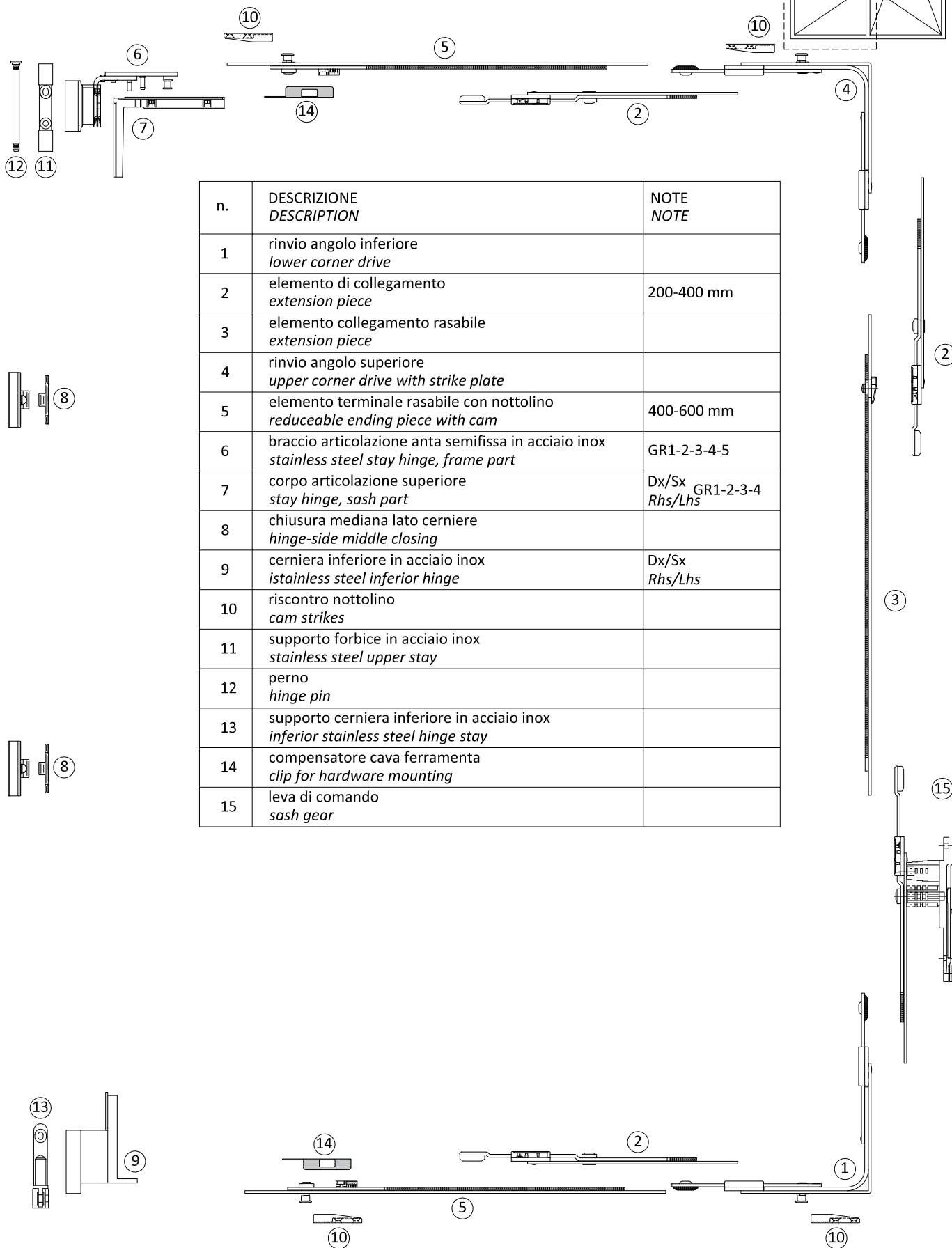
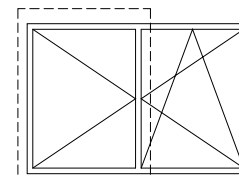

n.	DESCRIZIONE DESCRIPTION	NOTE NOTE
1	rinvio angolo inferiore lower corner drive	
2	elemento di collegamento extension piece	200-400 mm
3	elemento collegamento rasabile extension piece	
4	rinvio angolo superiore upper corner drive with strike plate	
5	elemento terminale rasabile con nottolino reduceable ending piece with cam	400-600 mm
6	braccio articolazione anta semifissa in acciaio inox stainless steel stay hinge, frame part	GR1-2-3-4-5
7	corpo articolazione superiore stay hinge, sash part	Dx/Sx GR1-2-3-4 Rhs/Lhs
8	chiusura mediana lato cerniere hinge-side middle closing	
9	cerniera inferiore in acciaio inox stainless steel inferior hinge	Dx/Sx Rhs/Lhs
10	riscontro nottolino cam strikes	
11	supporto forbice in acciaio inox stainless steel upper stay	
12	perno hinge pin	
13	supporto cerniera inferiore in acciaio inox inferior stainless steel hinge stay	
14	compensatore cava ferramenta clip for hardware mounting	
15	leva di comando sash gear	

Easy

peso massimo anta 130 kg  
maximum leaf weight 130 kg

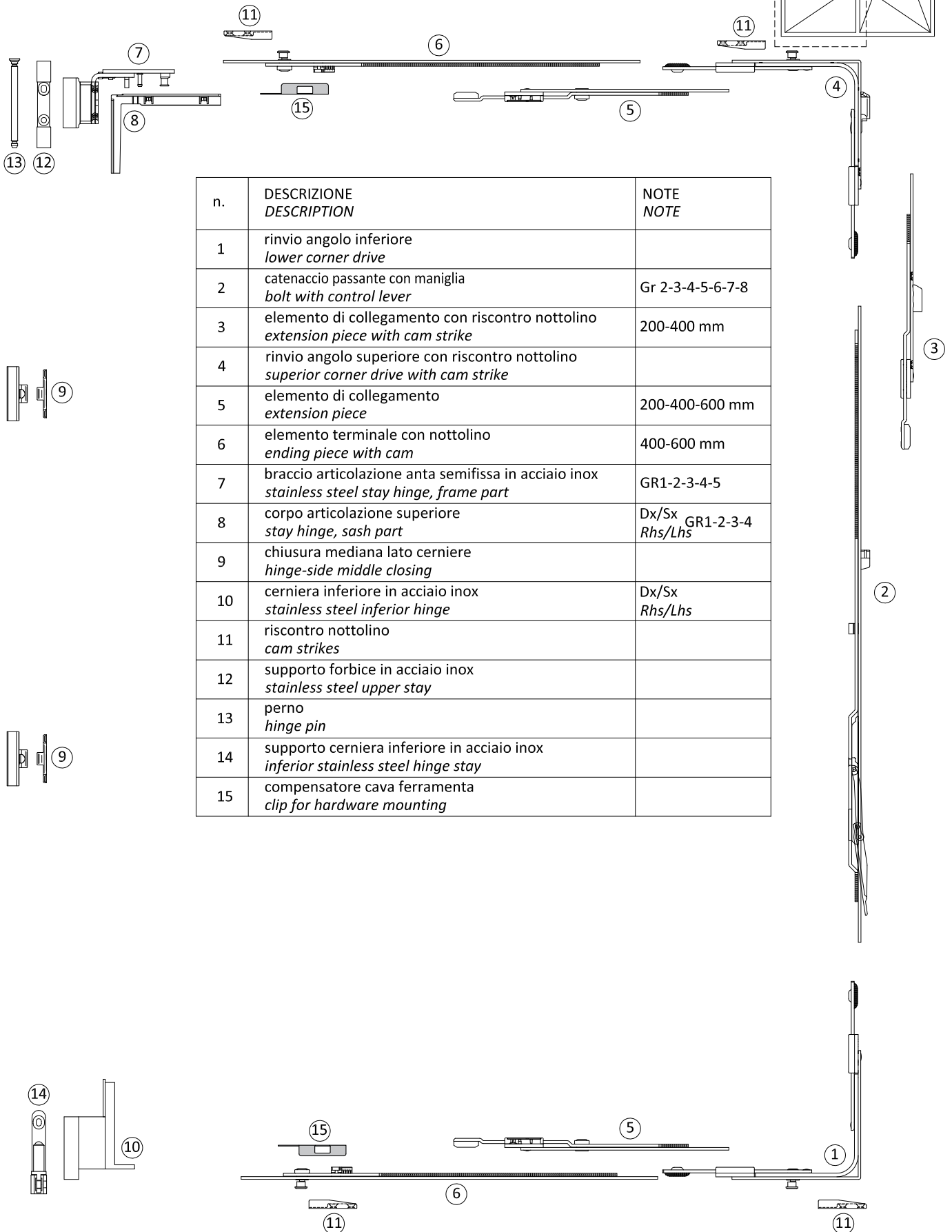
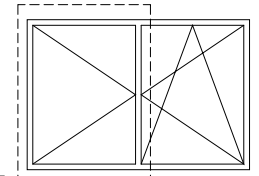

n.	DESCRIZIONE DESCRIPTION	NOTE NOTE
1	rinvio angolo inferiore lower corner drive	
2	catenaccio passante con maniglia bolt with control lever	Gr 2-3-4-5-6-7-8
3	elemento di collegamento con riscontro nottolino extension piece with cam strike	200-400 mm
4	rinvio angolo superiore con riscontro nottolino superior corner drive with cam strike	
5	elemento di collegamento extension piece	200-400-600 mm
6	elemento terminale con nottolino ending piece with cam	400-600 mm
7	braccio articolazione anta semifissa in acciaio inox stainless steel stay hinge, frame part	GR1-2-3-4-5
8	corpo articolazione superiore stay hinge, sash part	Dx/Sx GR1-2-3-4 Rhs/Lhs
9	chiusura mediana lato cerniere hinge-side middle closing	
10	cerniera inferiore in acciaio inox stainless steel inferior hinge	Dx/Sx Rhs/Lhs
11	riscontro nottolino cam strikes	
12	supporto forbice in acciaio inox stainless steel upper stay	
13	perno hinge pin	
14	supporto cerniera inferiore in acciaio inox inferior stainless steel hinge stay	
15	compensatore cava ferramenta clip for hardware mounting	



RC2

peso massimo anta 130 kg  
maximum leaf weight 130 kg

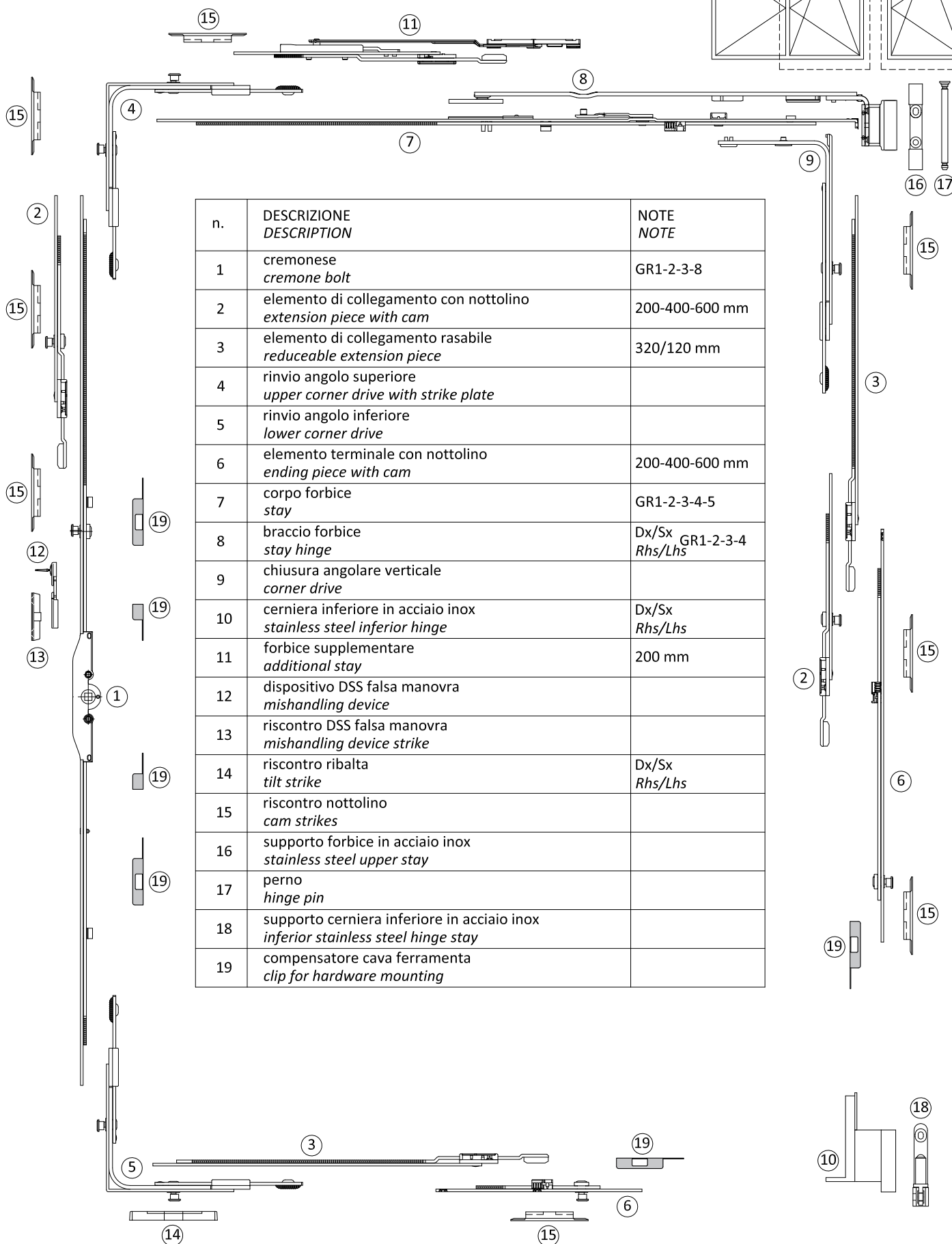
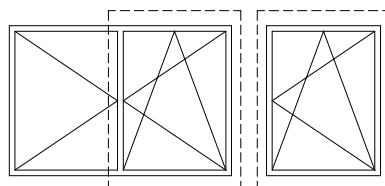

n.	DESCRIZIONE DESCRIPTION	NOTE NOTE
1	cremonese cremone bolt	GR1-2-3-8
2	elemento di collegamento con nottolino extension piece with cam	200-400-600 mm
3	elemento di collegamento rasabile reduceable extension piece	320/120 mm
4	rinvio angolo superiore upper corner drive with strike plate	
5	rinvio angolo inferiore lower corner drive	
6	elemento terminale con nottolino ending piece with cam	200-400-600 mm
7	corpo forbice stay	GR1-2-3-4-5
8	braccio forbice stay hinge	Dx/Sx GR1-2-3-4 Rhs/Lhs
9	chiusura angolare verticale corner drive	
10	cerniera inferiore in acciaio inox stainless steel inferior hinge	Dx/Sx Rhs/Lhs
11	forbice supplementare additional stay	200 mm
12	dispositivo DSS falsa manovra mishandling device	
13	riscontro DSS falsa manovra mishandling device strike	
14	riscontro ribalta tilt strike	Dx/Sx Rhs/Lhs
15	riscontro nottolino cam strikes	
16	supporto forbice in acciaio inox stainless steel upper stay	
17	perno hinge pin	
18	supporto cerniera inferiore in acciaio inox inferior stainless steel hinge stay	
19	compensatore cava ferramenta clip for hardware mounting	



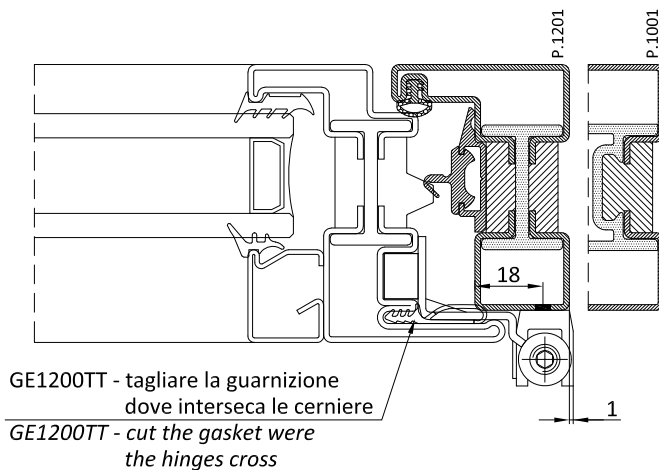
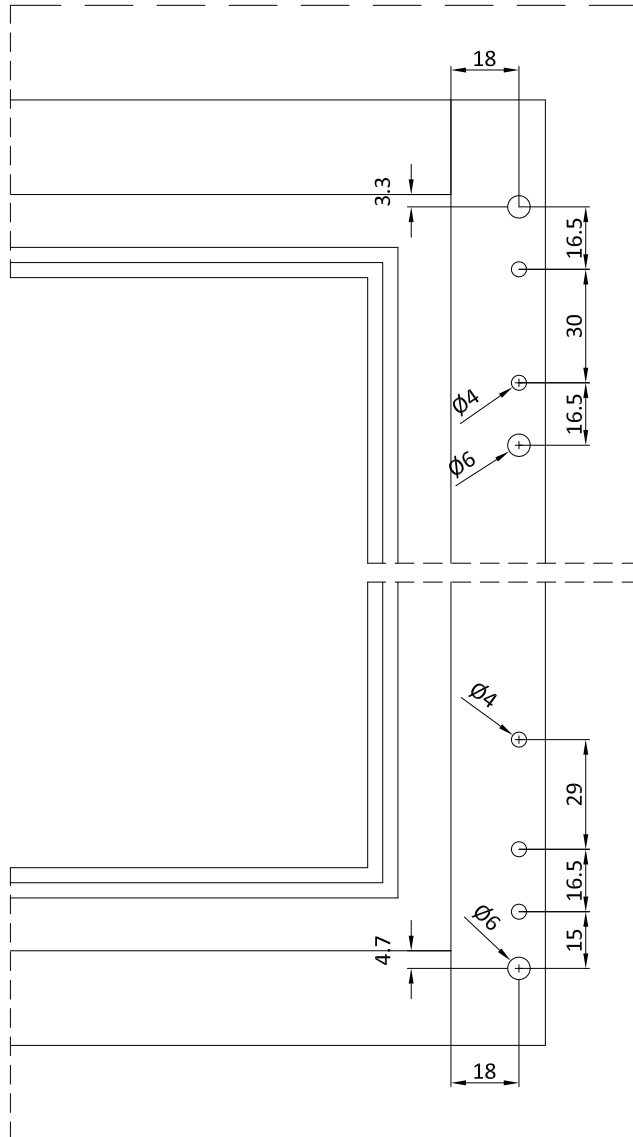
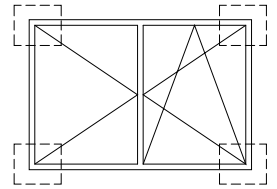

Fori eseguibili con maschera AT1242  
 Holes to be done with AT1242



Easy

peso massimo anta 180 kg  
(AC1237)  
maximum leaf weight 180 kg  
(AC1237)

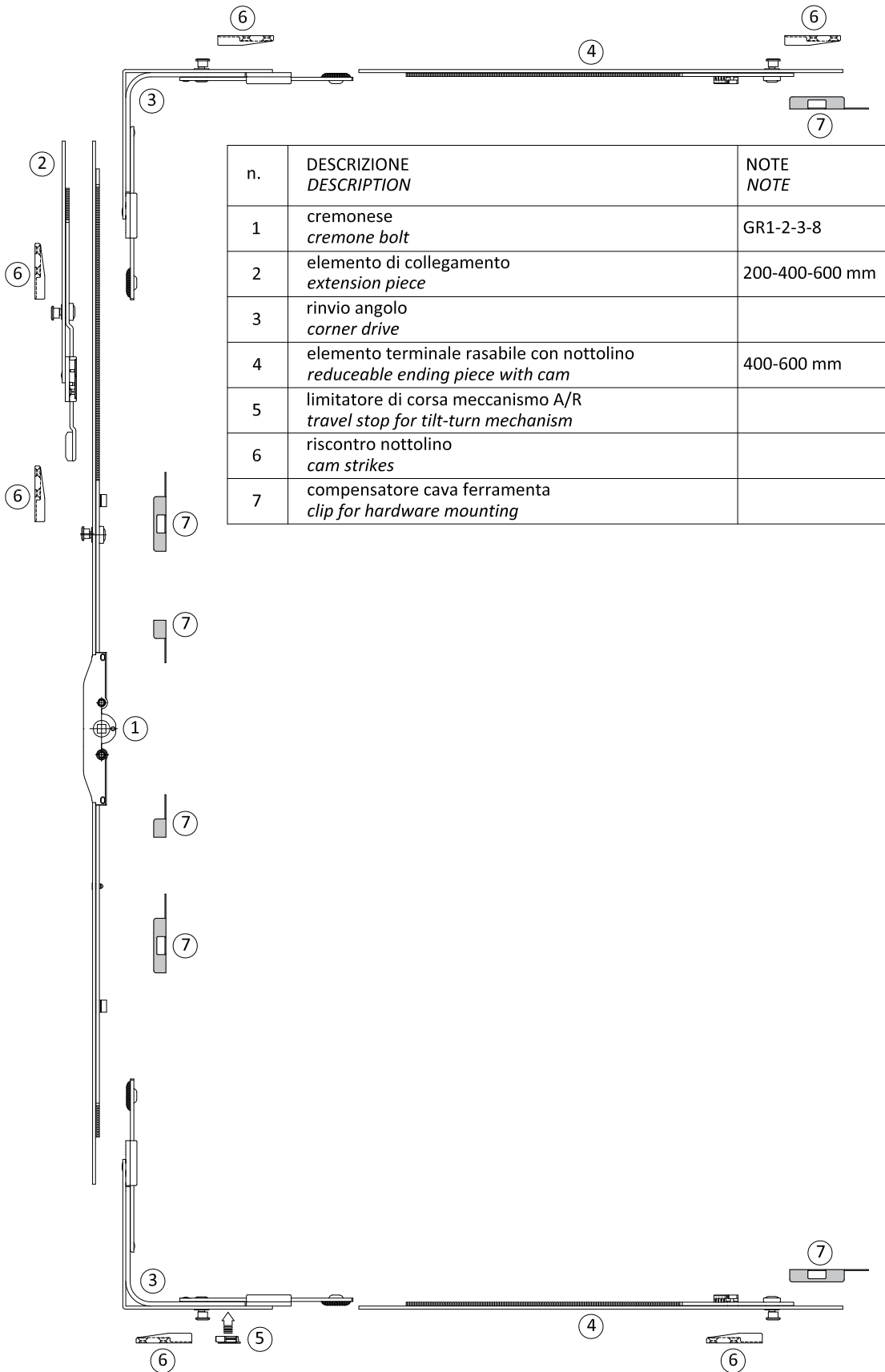
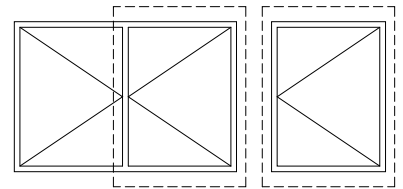

n.	DESCRIZIONE DESCRIPTION	NOTE NOTE
1	cremonese <i>cremone bolt</i>	GR1-2-3-8
2	elemento di collegamento <i>extension piece</i>	200-400-600 mm
3	rinvio angolo <i>corner drive</i>	
4	elemento terminale rasabile con nottolino <i>reduceable ending piece with cam</i>	400-600 mm
5	limitatore di corsa meccanismo A/R <i>travel stop for tilt-turn mechanism</i>	
6	riscontro nottolino <i>cam strikes</i>	
7	compensatore cava ferramenta <i>clip for hardware mounting</i>	

Easy

peso massimo anta 180 kg  
(AC1237)  
maximum leaf weight 180 kg  
(AC1237)

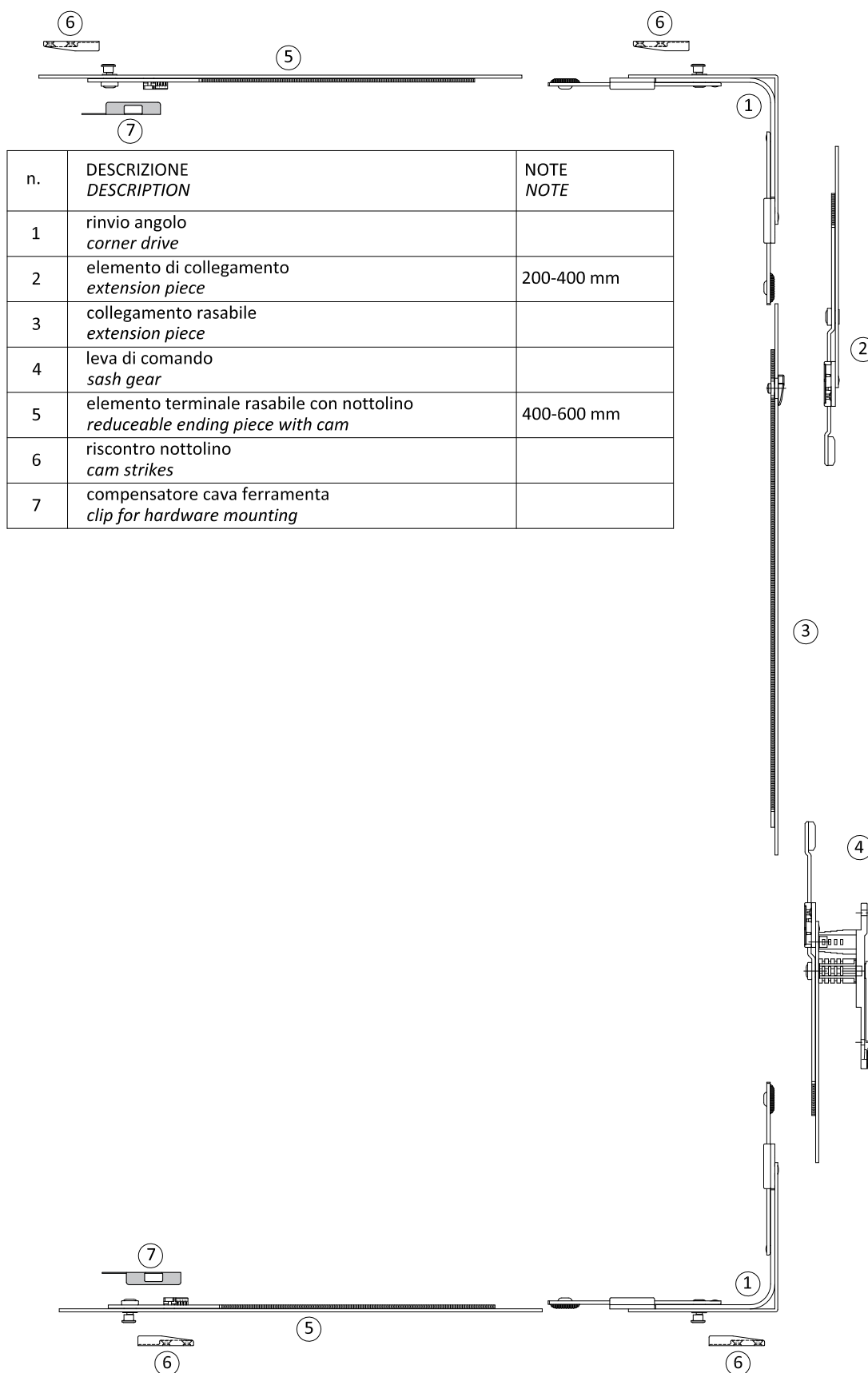
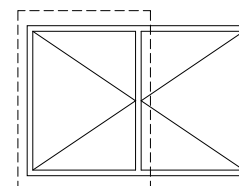

Easy

peso massimo anta 180 kg  
(AC1237)  
maximum leaf weight 180 kg  
(AC1237)

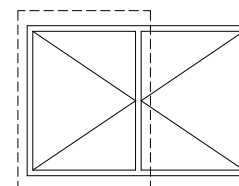

n.	DESCRIZIONE DESCRIPTION	NOTE NOTE
1	rinvio angolo inferiore lower corner drive	
2	catenaccio passante con maniglia bolt with control lever	Gr 2-3-4-5-6-7-8
3	elemento di collegamento con riscontro nottolino extension piece with cam strike	200-400 mm
4	rinvio angolo superiore upper corner drive with strike plate	
5	elemento terminale con nottolino ending piece with cam	400-600 mm
6	riscontro nottolino cam strikes	
7	compensatore cava ferramenta clip for hardware mounting	

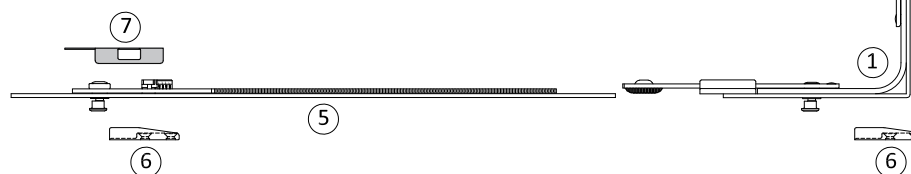
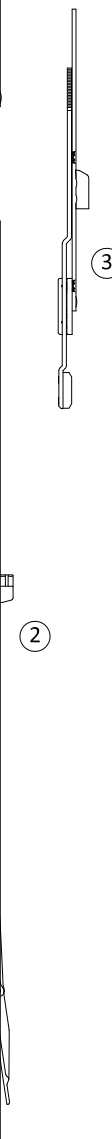

Easy RC2	H cava ferramenta H hardware slot [mm]	X [mm]	Y [mm]
	661 → 1000	183	173
	1001 → 1800	275	265
	1801 → 2400	855	845

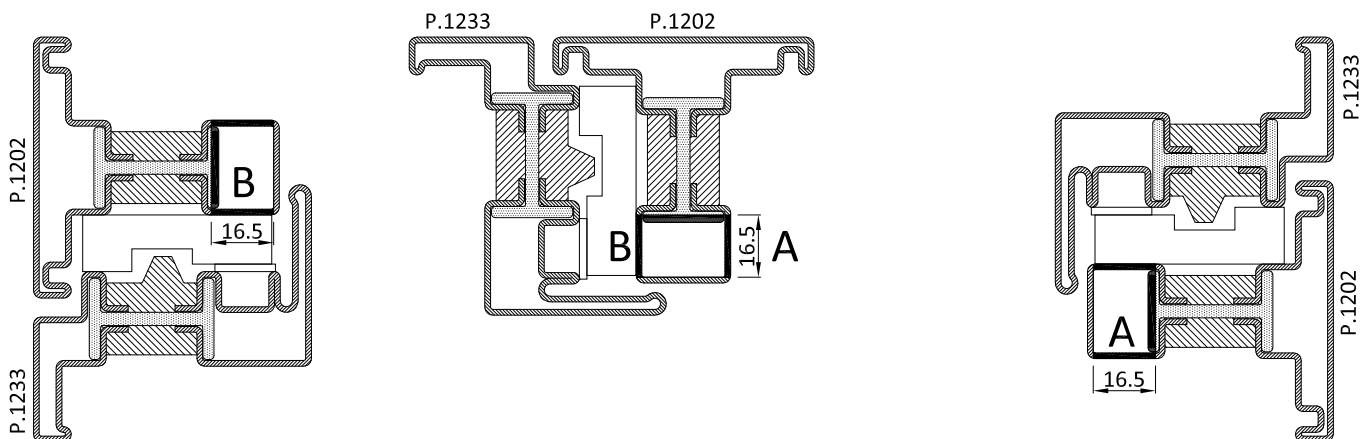
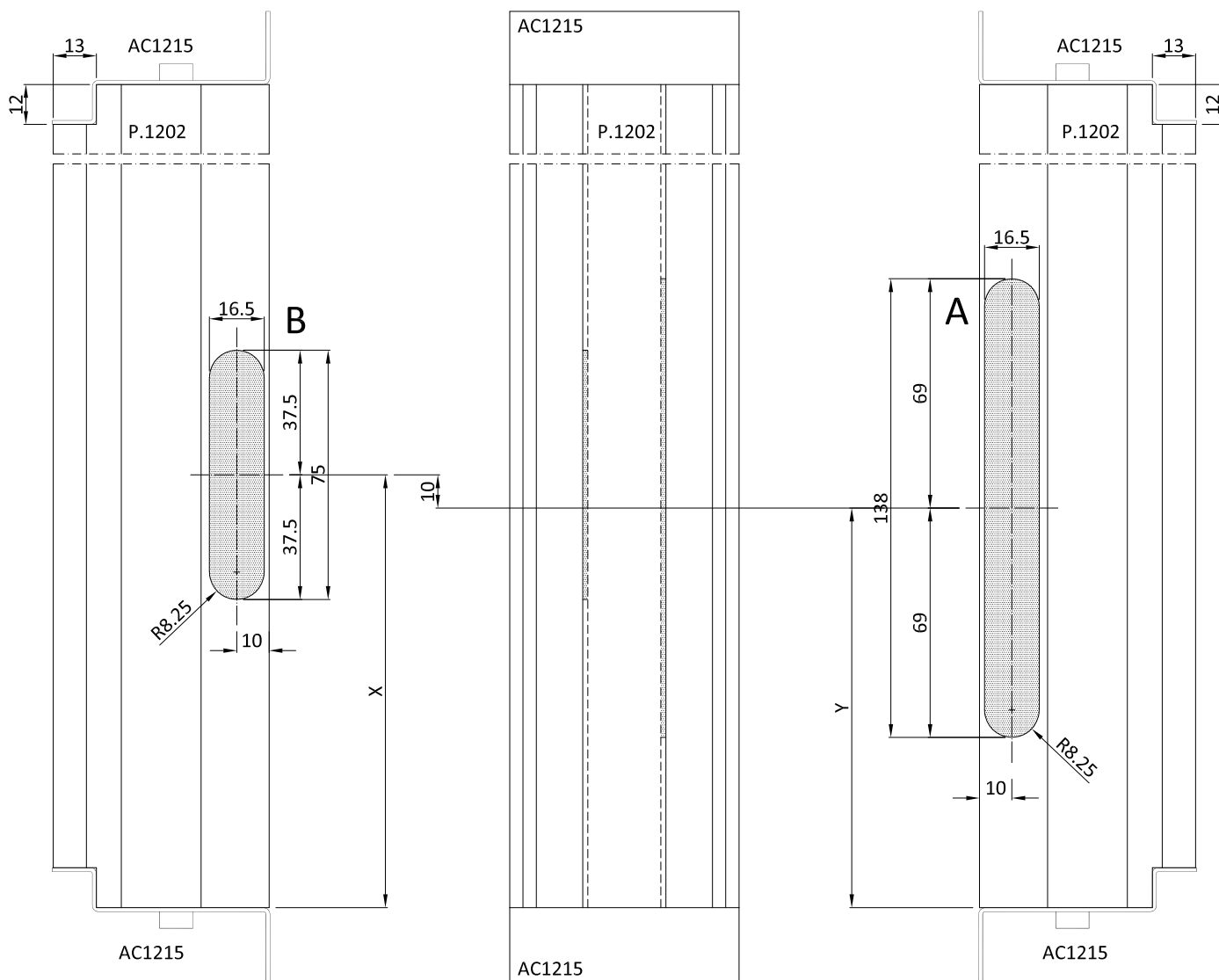
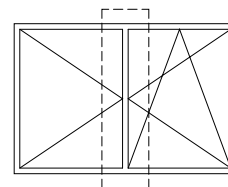

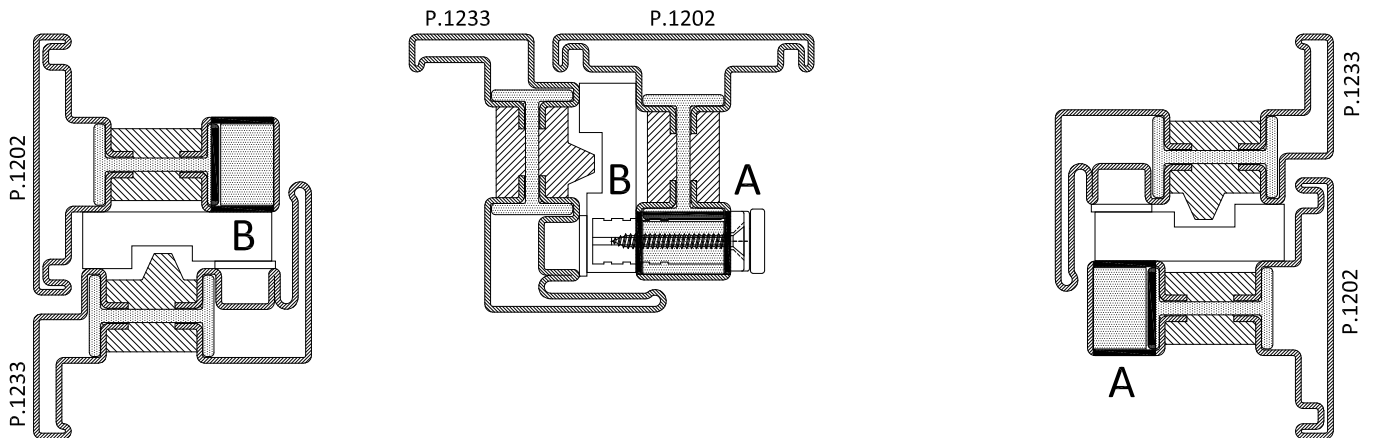
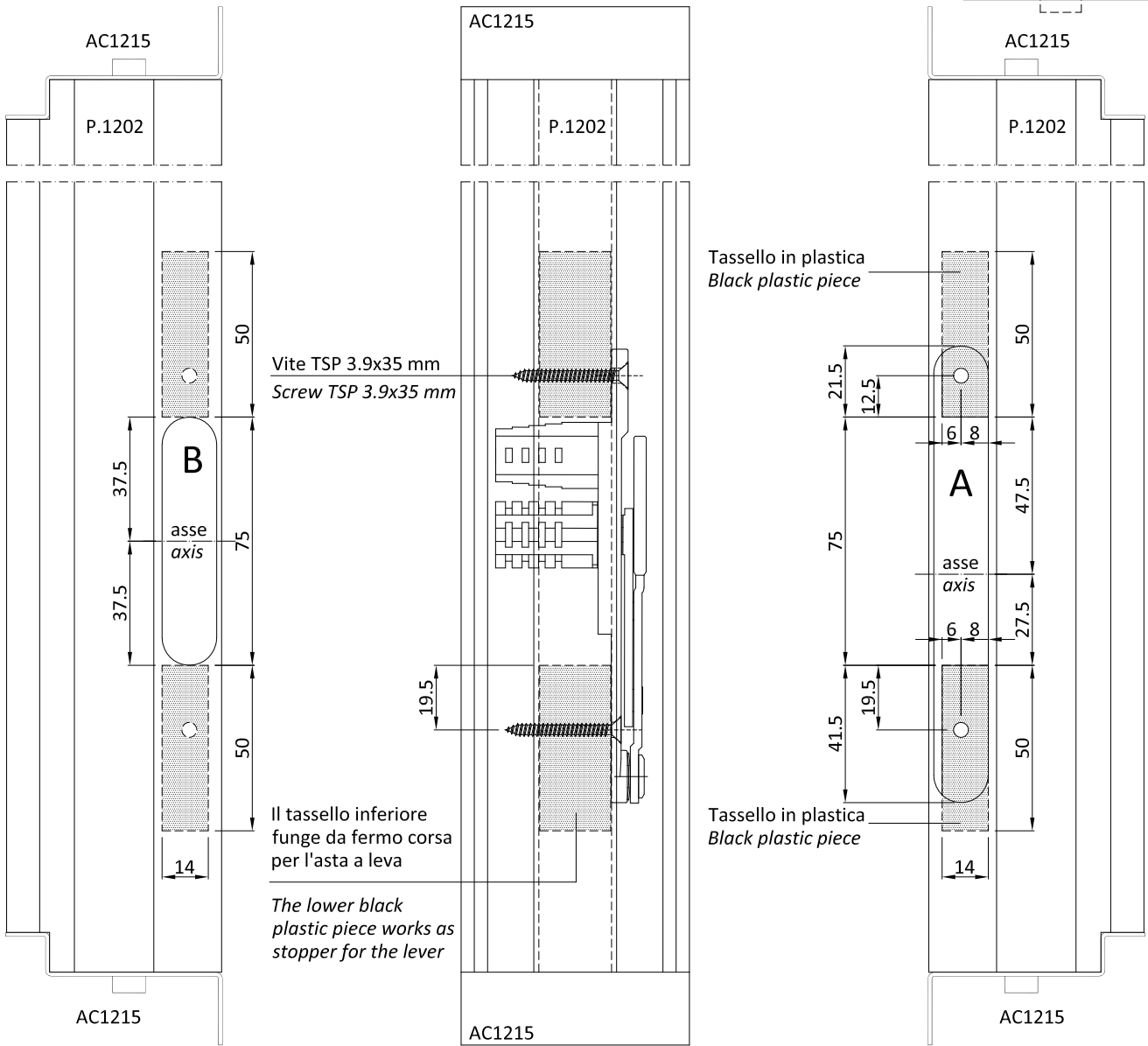
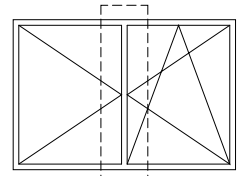



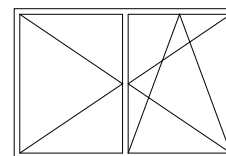

Lavorazione da eseguire sui componenti rasabili della ferramenta  
Working on the cuttable pieces of the hardware

- 1 - Eseguire taglio della ferramenta sfalsato
  - 2 - Eseguire foro e svasatura
- 1 - Cutting of the hardware
- 2 - Hole drilling and countersink

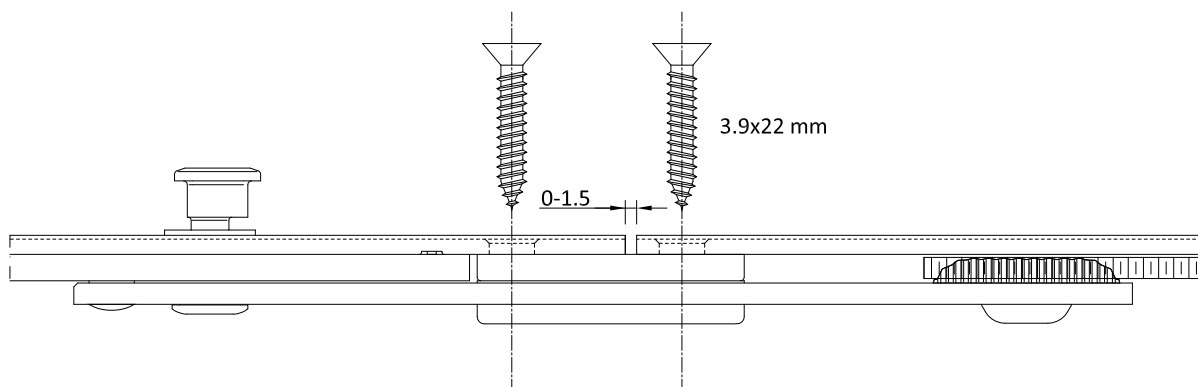
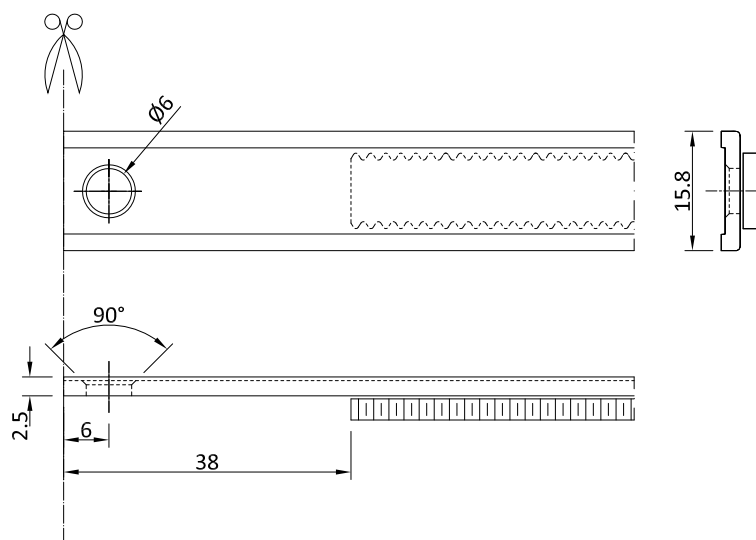

Lavorazione eseguibile con trancia ATG 311 o ATG 312  
Tooling possible with punching machine ATG 311 or ATG 312

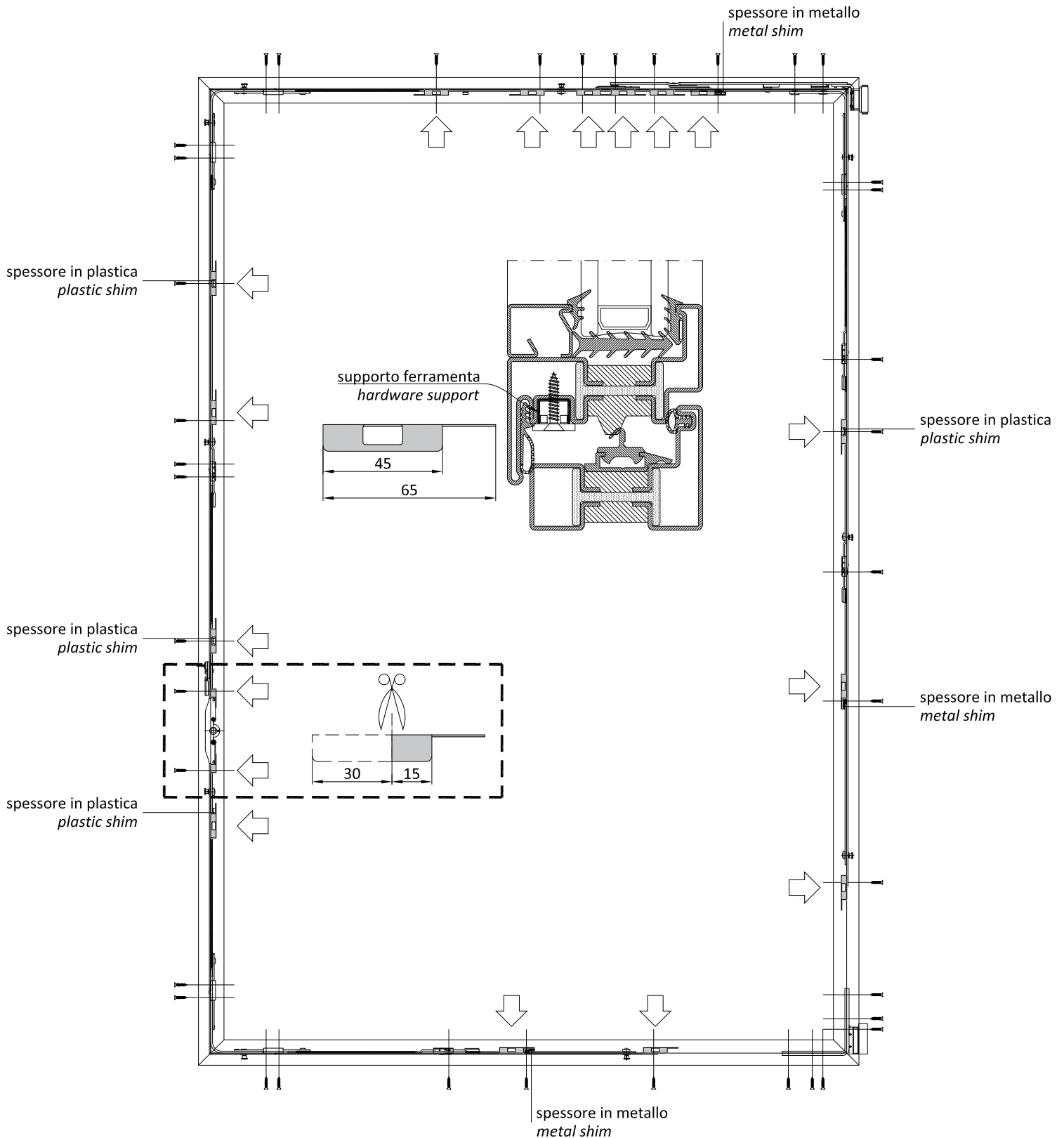
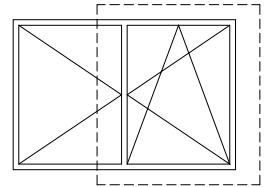

viti | screws TPS 3.9x22 mm



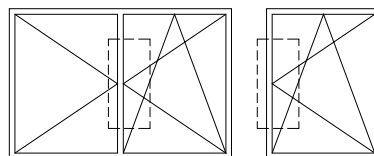

DSS

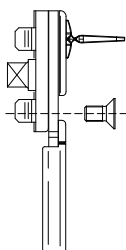
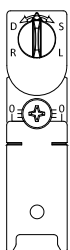

M4x8 mm

P.1201

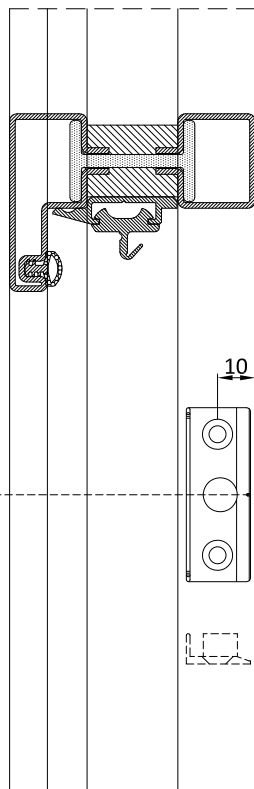

3.9x22 mm

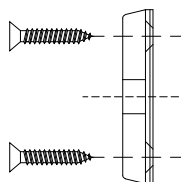

10

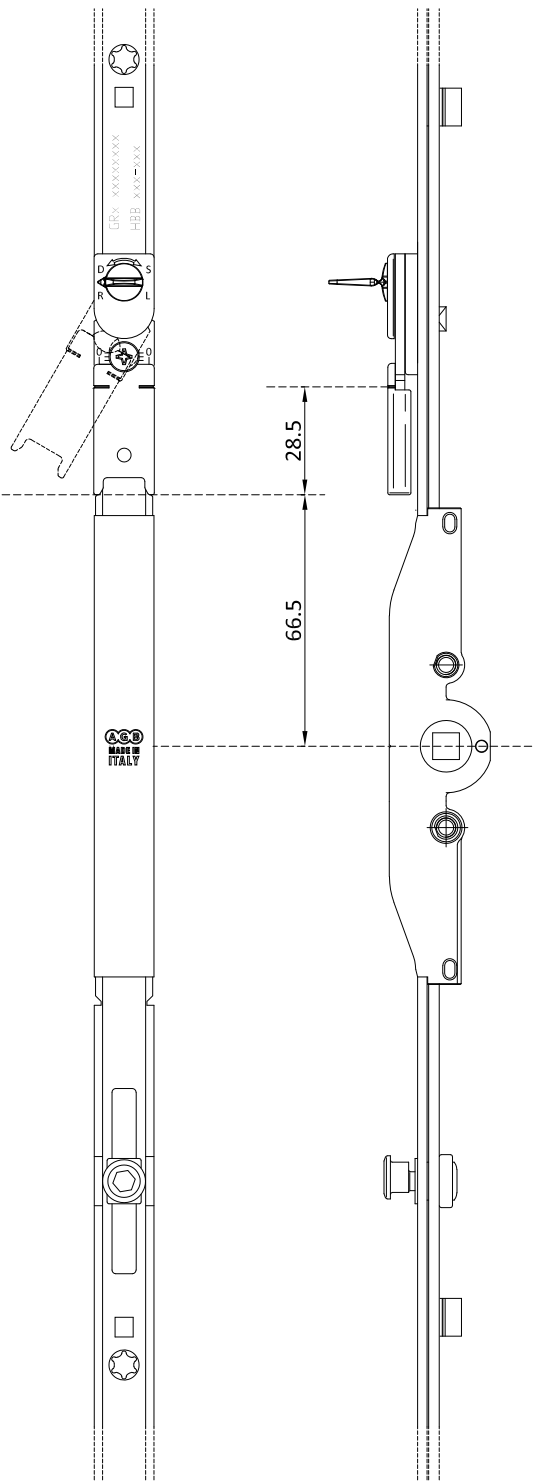

Regolazione  
Adjustment

+3 mm

0 mm

-3 mm

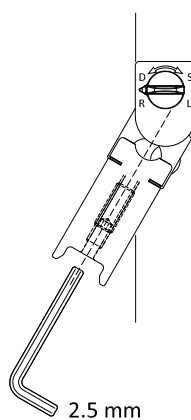
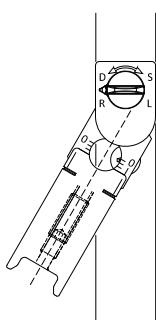

2.5 mm

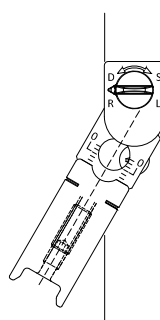

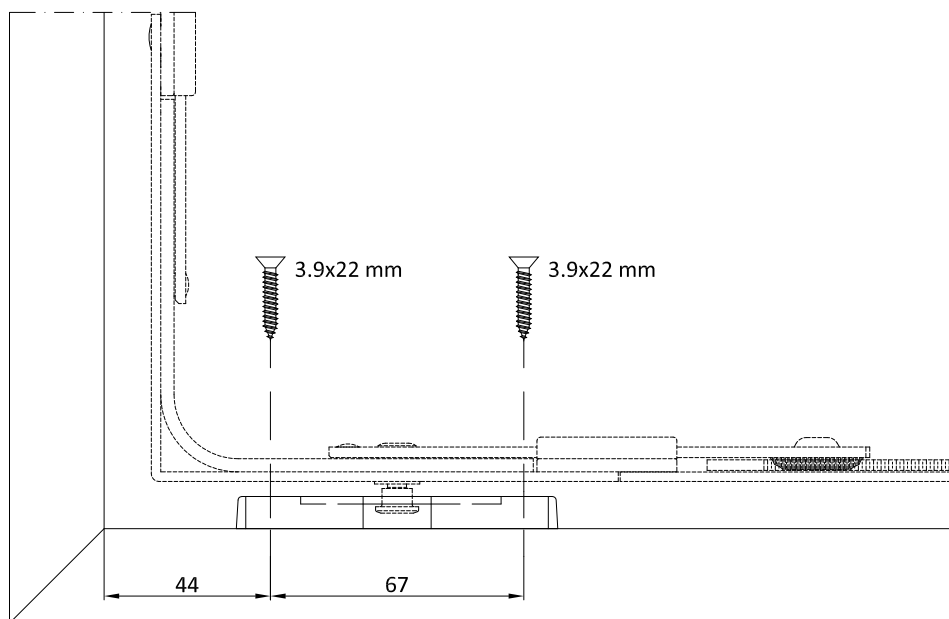

Easy

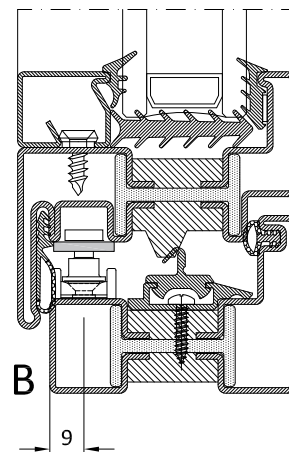
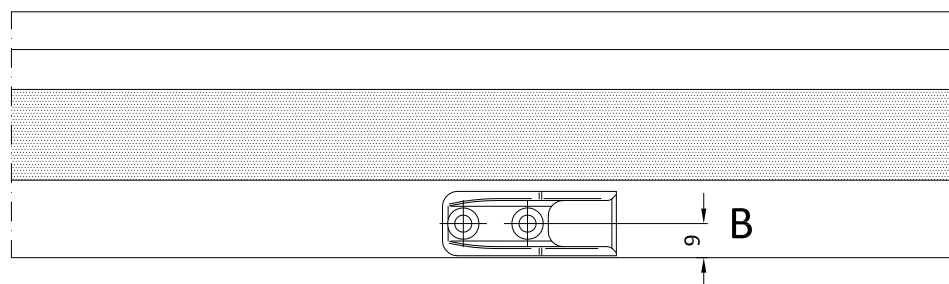
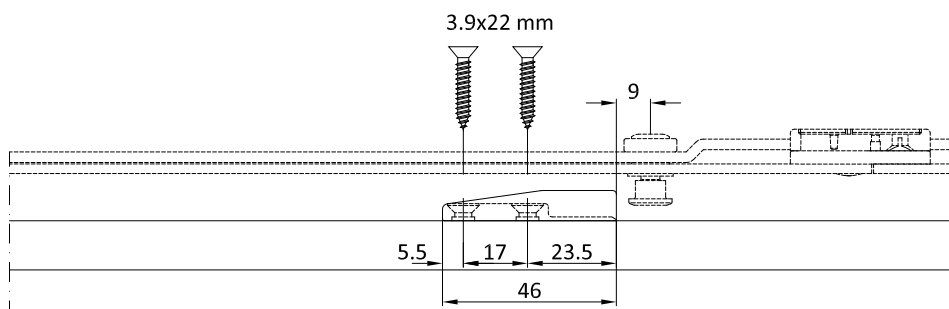
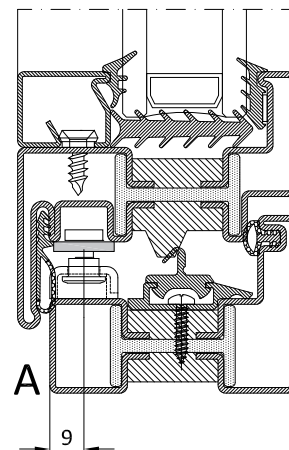
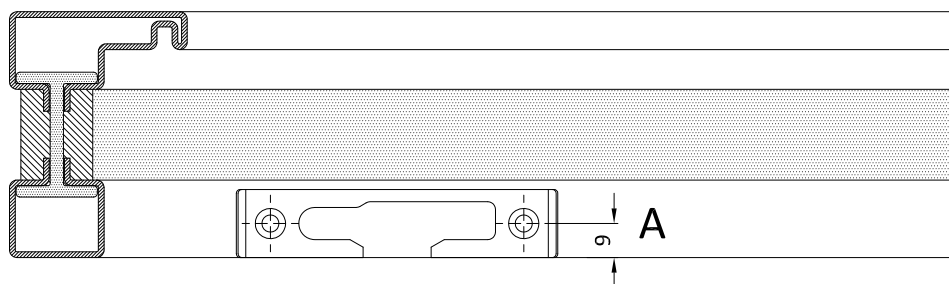
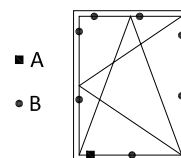

Easy

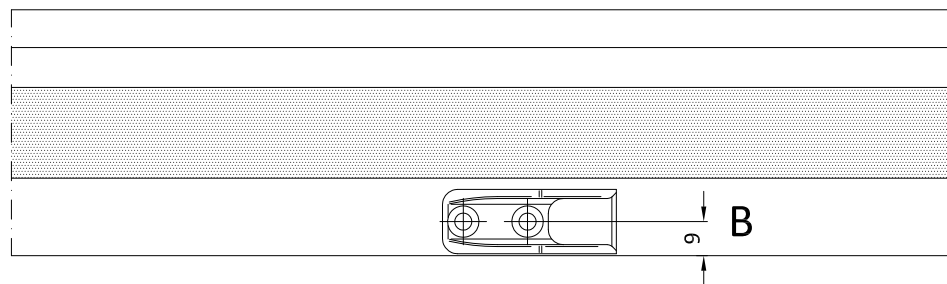
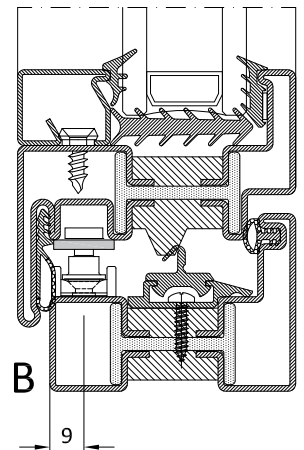
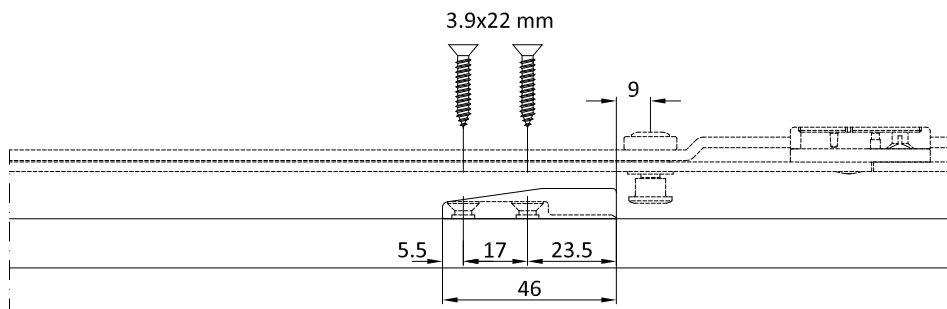
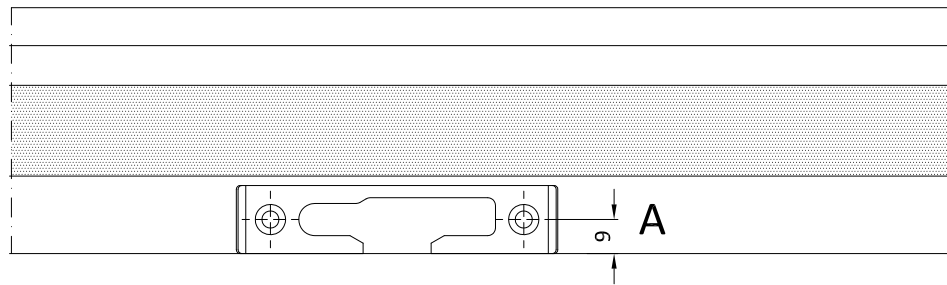
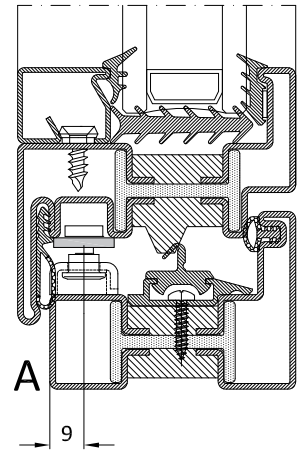
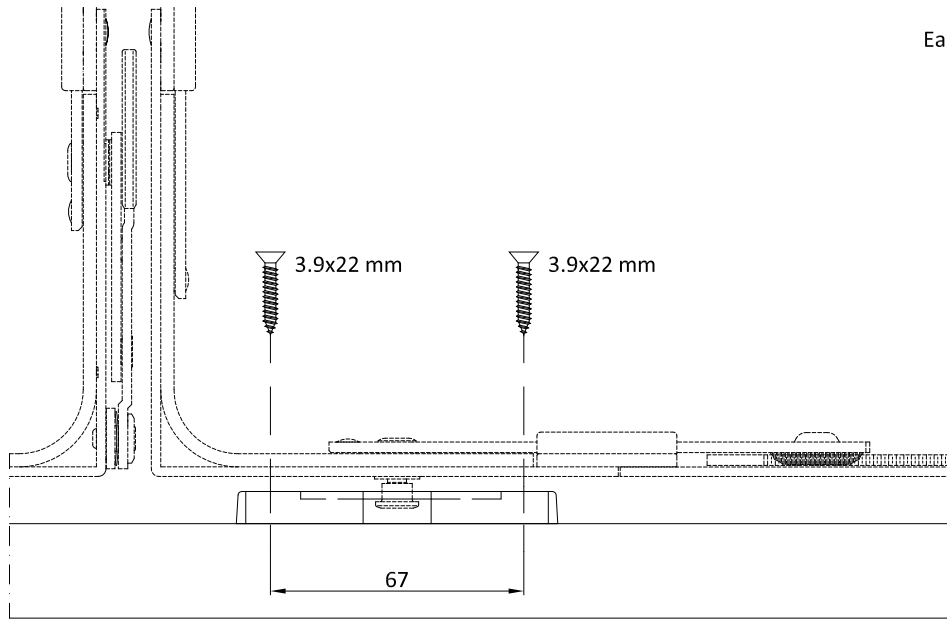
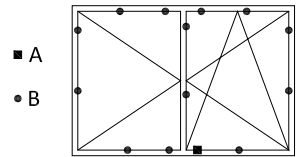

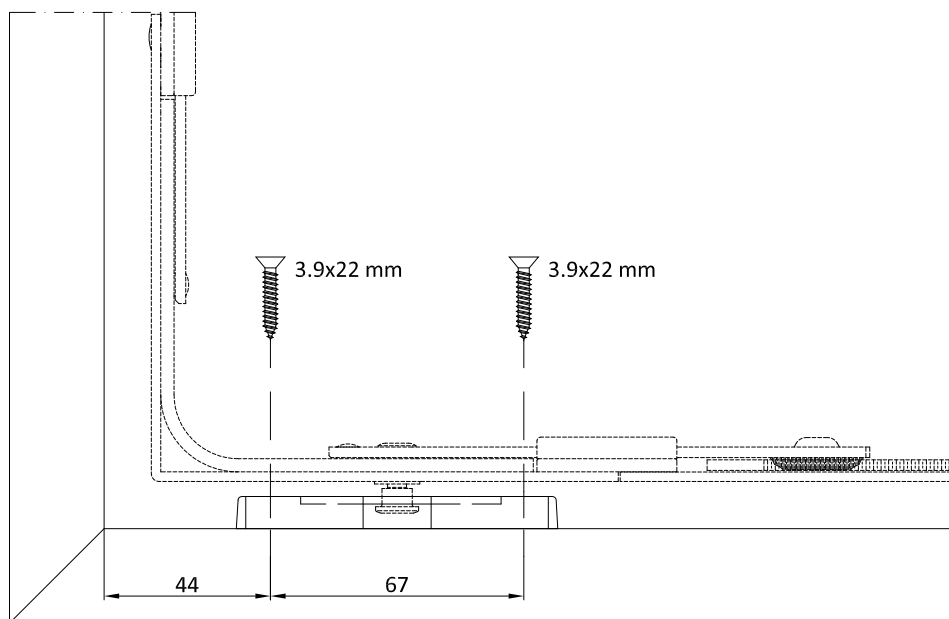

RC2

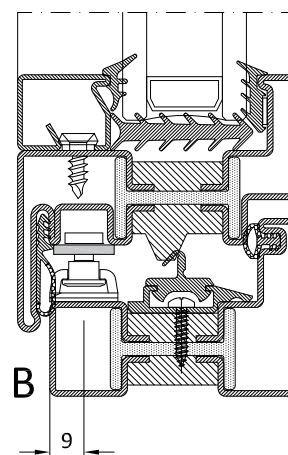
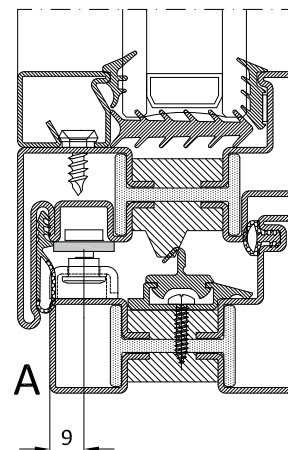
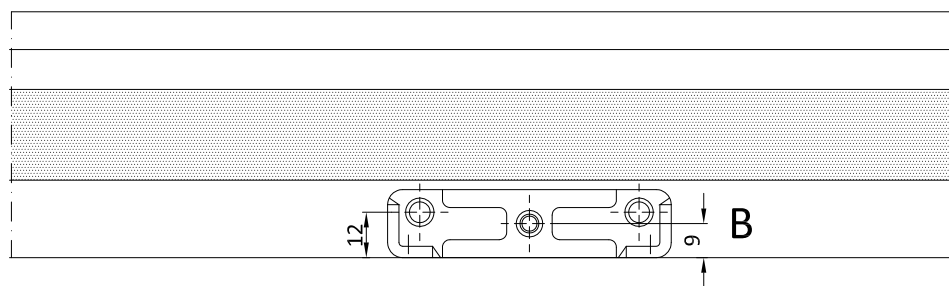
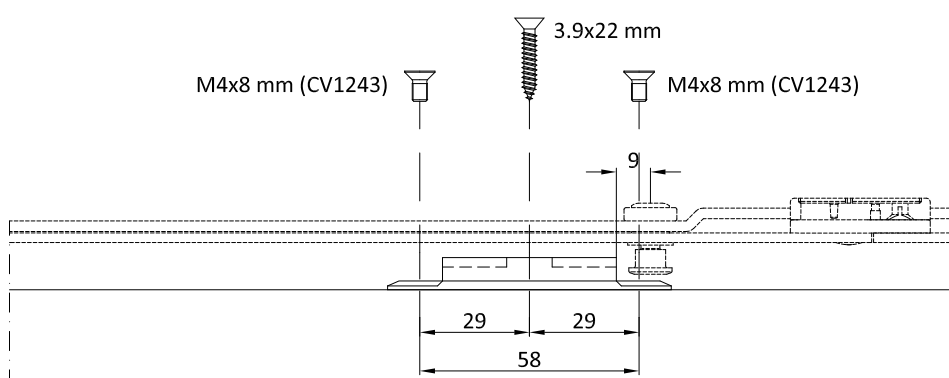
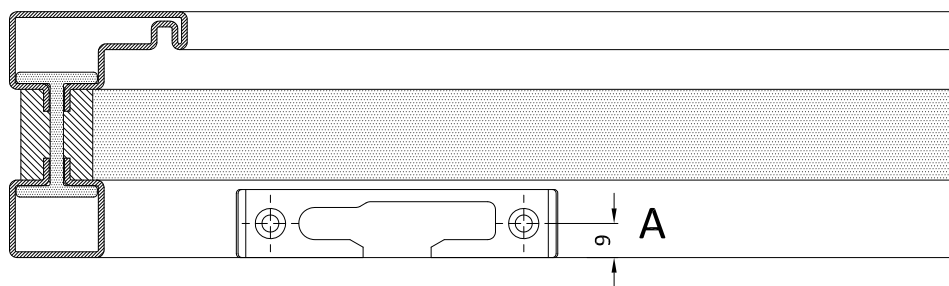
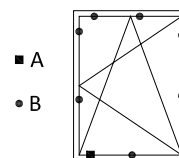

Fori eseguibili con  
maschera ATG303  
Holes to be done with  
ATG303

RC2

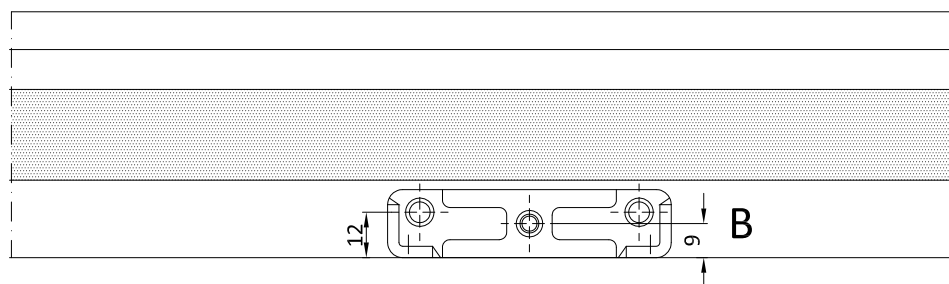
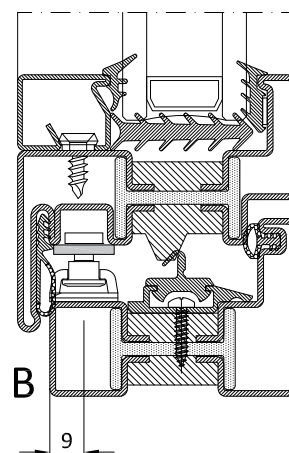
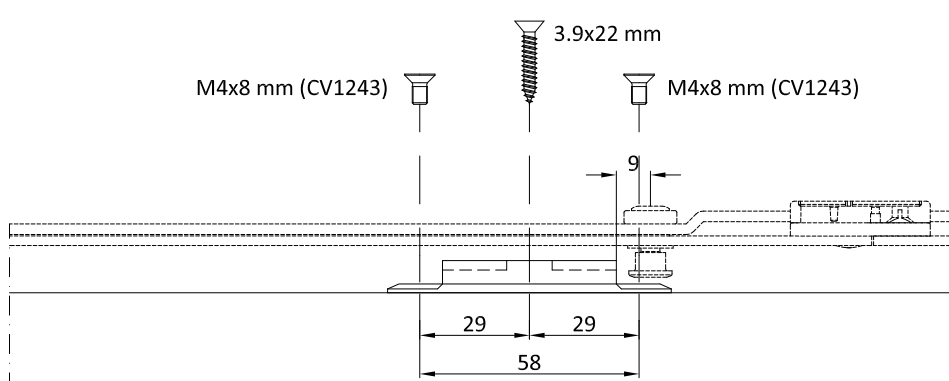
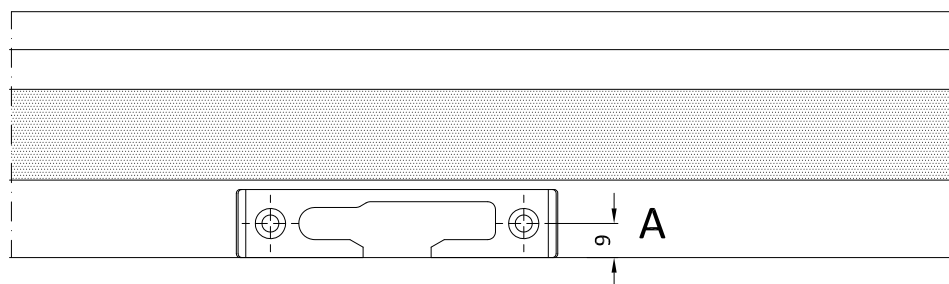
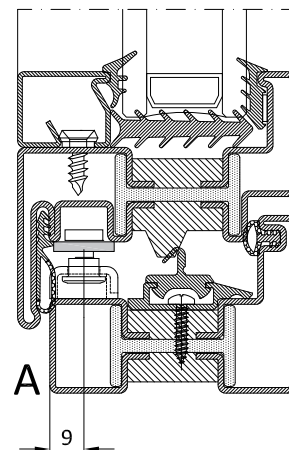
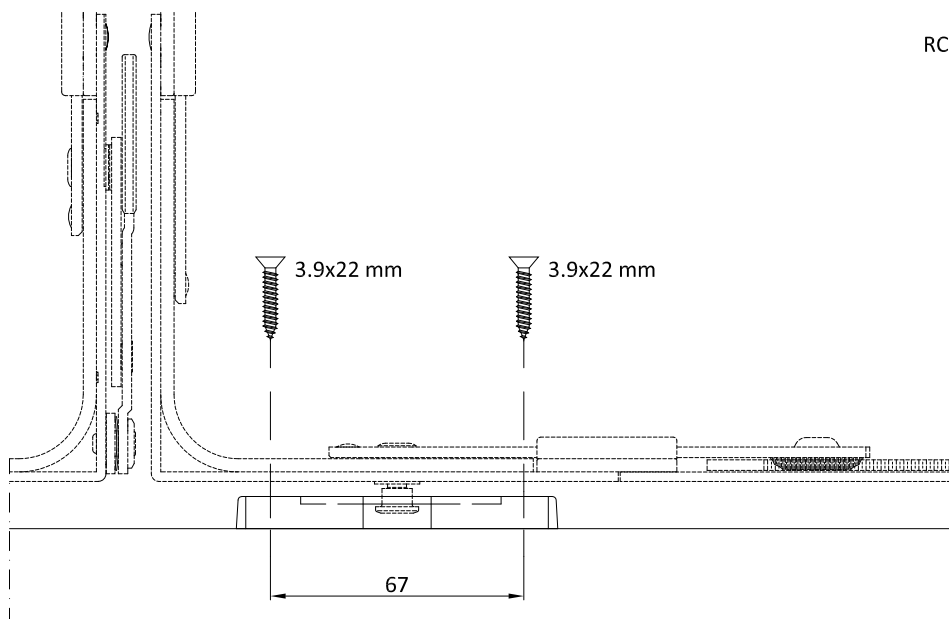
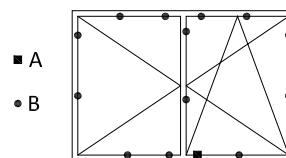

Fori eseguibili con  
maschera ATG303  
Holes to be done with  
ATG303

AG6530

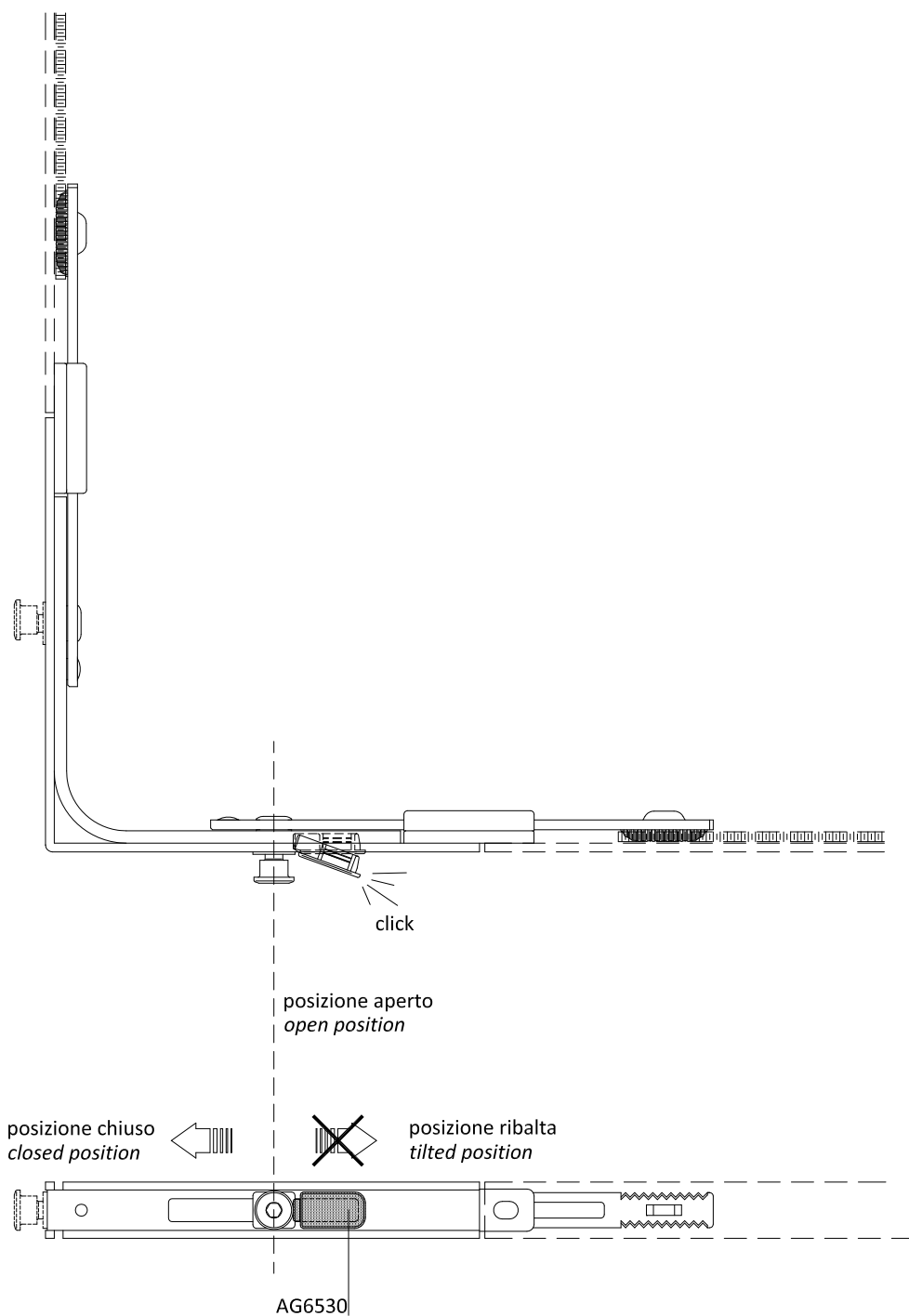
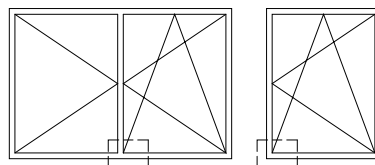
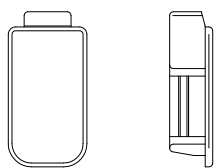



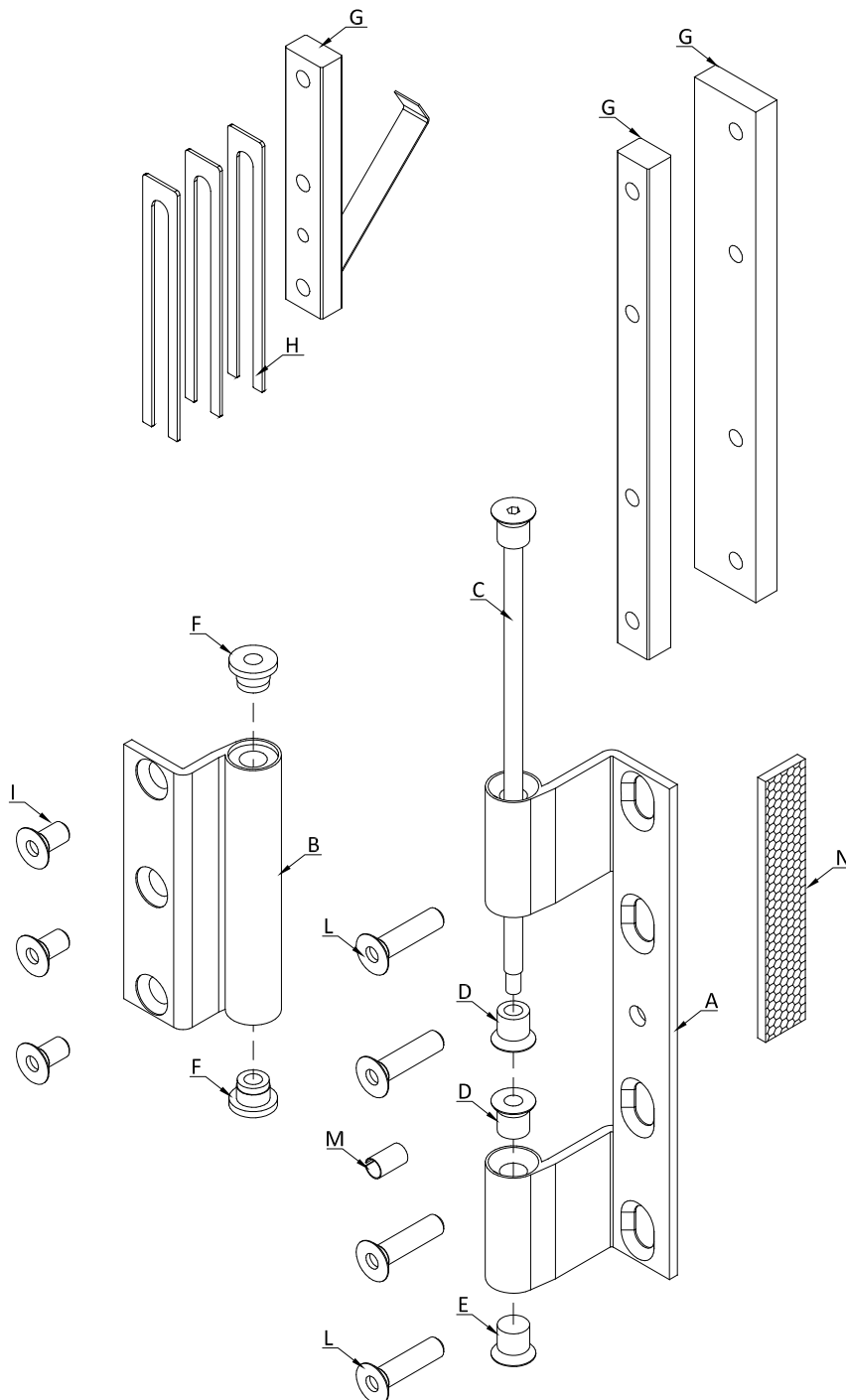
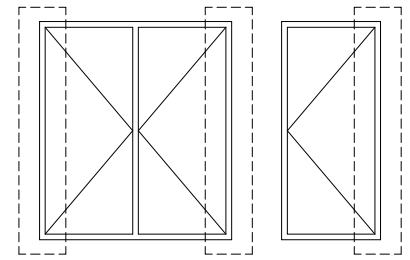

- A) Corpo cerniera A
- B) Corpo cerniera B
- C) Perno
- D) Guida perno
- E) Tappo a vite
- F) Bronzina
- G) Rinforzi interni
- H) Distanziale di regolazione
- I) Viti acciaio inox TSPEI M6 x 12 mm
- L) Viti acciaio inox TSPEI M6 x 25 mm
- M) Spina inox  $\varnothing 6 \times 10$  mm da inserire dopo la regolazione dell'anta
- N) Guarnizione adesiva 15x3 mm

- A) Body hinge A
- B) Body hinge B
- C) Pin
- D) Pin groove/guide
- E) Screw cap
- F) Bronze bush
- G) Internal reinforcements
- H) Regulating spacer
- I) Stainless steel screws TSPEI M6 x 12 mm
- L) Stainless steel screws TSPEI M6 x 25 mm
- M) Stainless steel pin  $\varnothing 6 \times 10$  mm to insert after regulating the leaf
- N) adhesive gasket 15x3 mm

H= 160 mm  
 $\varnothing 15$  mm

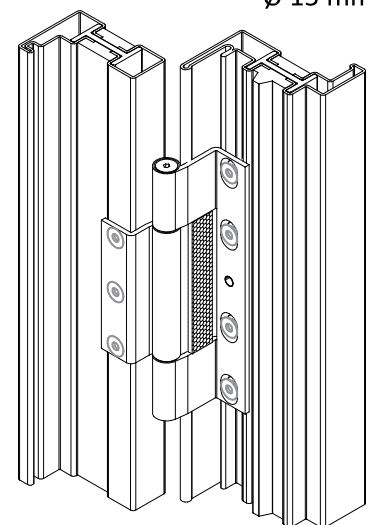



LAVORAZIONE VALIDA ANCHE PER CERNIERE INTERMEDIE / AGGIUNTIVE

Dopo aver tagliato montanti e traversi dell'anta e del telaio ed aver effettuato le lavorazioni delle squadrette, forare con punta  $\varnothing 5,5$  il profilo "telaio" ed il profilo "anta" come indicato nel disegno.

Prima di assemblare il telaio e l'anta inserire i rinforzi "A" - "B" e bloccarli con le viti in dotazione.

Effettuare le medesime lavorazioni per la cerniera superiore e per le eventuali posizioni intermedie.

Forare la squadretta AC1207I di assiemaggio dell'anta e filettare i fori M5.

Dopo aver assemblato definitivamente l'infisso, vetri compresi, registrare le cerniere e bloccare l'elemento femmina della cerniera all'anta con la spina  $\varnothing 6$  in dotazione

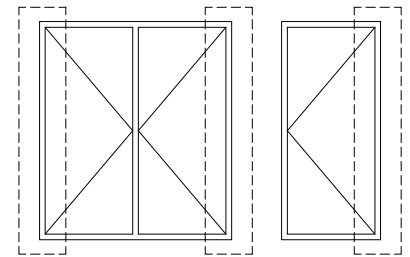

TOOLING VALID ALSO FOR INTERMEDIATE/ADDITIONAL HINGES

After cutting mullions and transoms for the wing and frame and carrying out the tooling with the corner brackets, drill the holes in the frame and wing profiles as indicated in the drawings. Use a  $\varnothing 5.5$  drill bit.

Before assembling the frame and the wing, insert the reinforcements "A" - "B" and secure them with the screws provided.

Carry out the same procedures for the upper hinge and for any other mid positions.

Drill a hole in the AC1207I assembling bracket for the wing and thread the M5 holes.

After assembling the door/window, glass included, adjust the hinges and secure the female element of the hinge to the wing with the  $\varnothing 6$  pin provided.

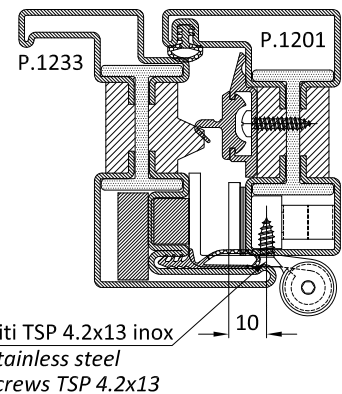

Viti TSP 4.2x13 inox  
Stainless steel  
screws TSP 4.2x13

PER ANTE CON PESO SUPERIORE A 180 kg

Eeguire sulla cerniera due fori svasati  $\varnothing 4,5$  dopo aver assemblato definitivamente l'infisso, vetri compresi, registrare le cerniere e bloccare con la spina  $\varnothing 6$  in dotazione l'elemento femmina sull'anta e l'elemento maschio al telaio con due viti TPS 4,2x13

FOR WINGS HEAVIER THAN 180 kg

After assembling the door/window, glass included, drill 2  $\varnothing 4.5$  countersunk holes in the hinge; adjust the hinges and secure the female element of the hinge to the wing with the  $\varnothing 6$  pin provided and the male element to the frame with 2 TPS 4.2x13 screws.

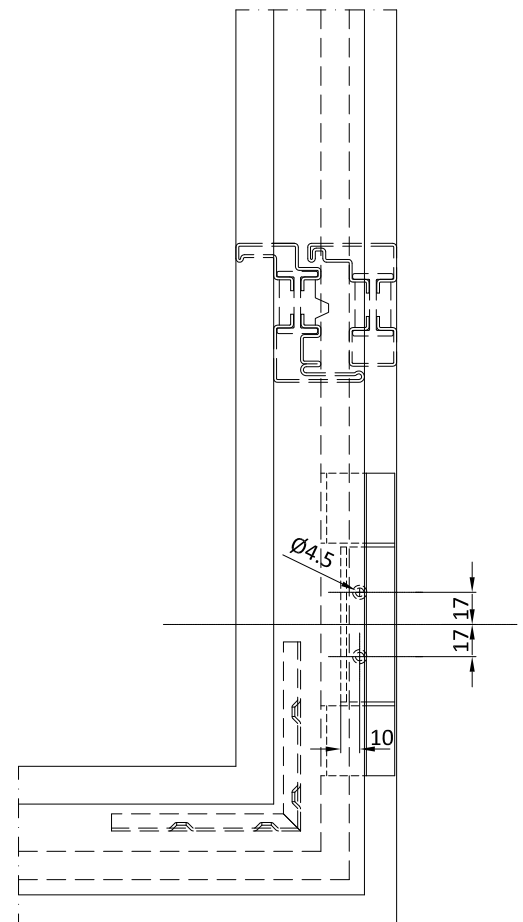

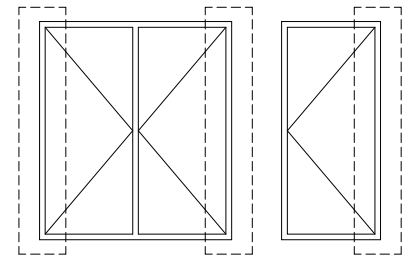
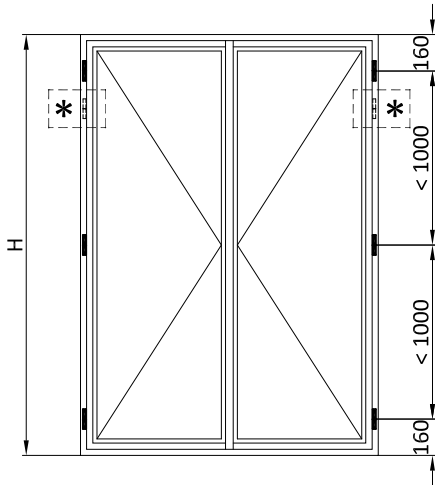

Peso max. per anta 80 kg  
Max. weight for leaf: 80 kg

\* Cerniera aggiuntiva per peso anta > di 80 kg - peso max 100 kg  
Additional hinge for leaf weight > 80 kg - max weight 100 kg

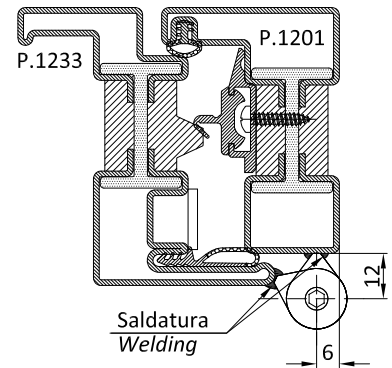

Posizionare le cerniere come da disegno saldandole sui alti.  
Position the hinges as in the drawing, welding them on the sides.

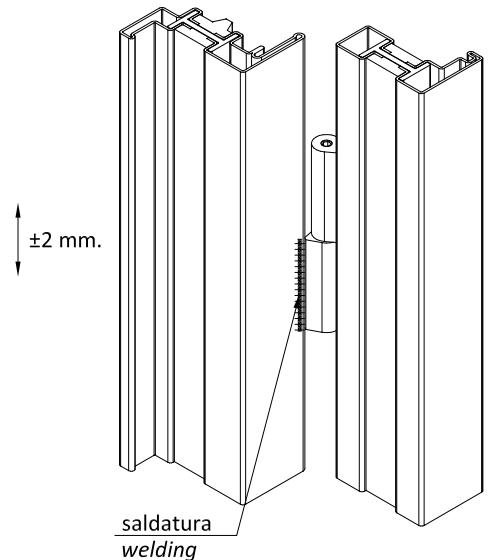
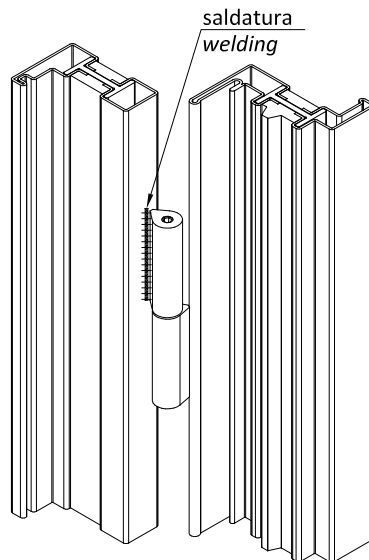
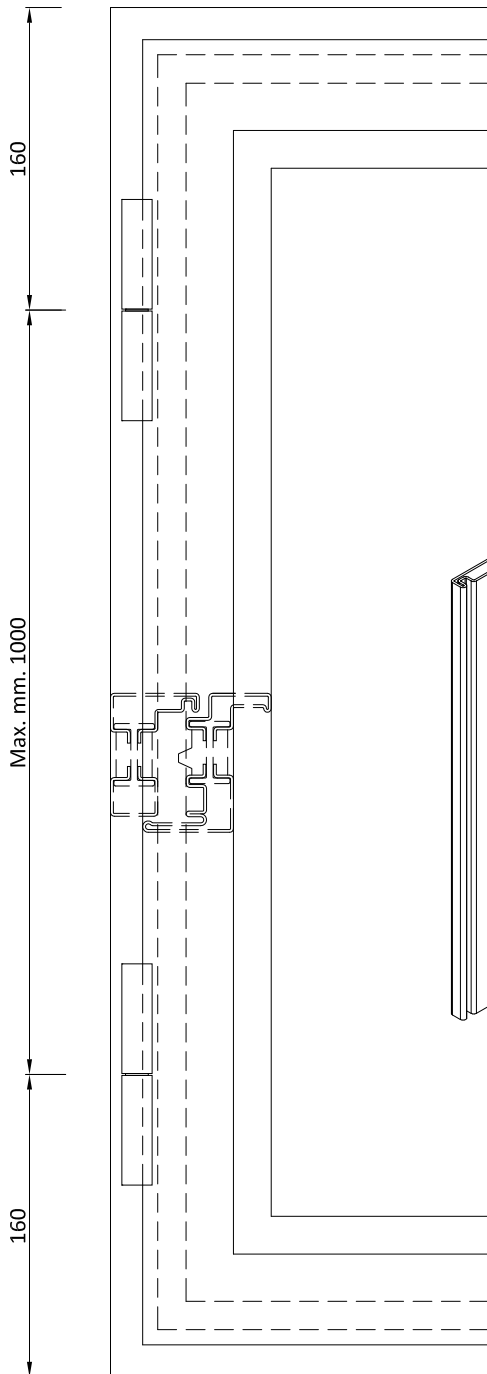

- La lavorazione può essere effettuata anche in posizioni intermedie dell'altezza della finestra.  
- La lavorazione SX è speculare alla DX.

- Tooling can be carried out also in intermediate positions regarding the height of the window.  
- Tooling on left is the same as that on the right.

$\alpha$	x [mm]	min. cava ferramenta hardware slot min.	[mm]
30°	192	445	
45°	182.5	435	
90°	130	385	
100°	117.5	370	

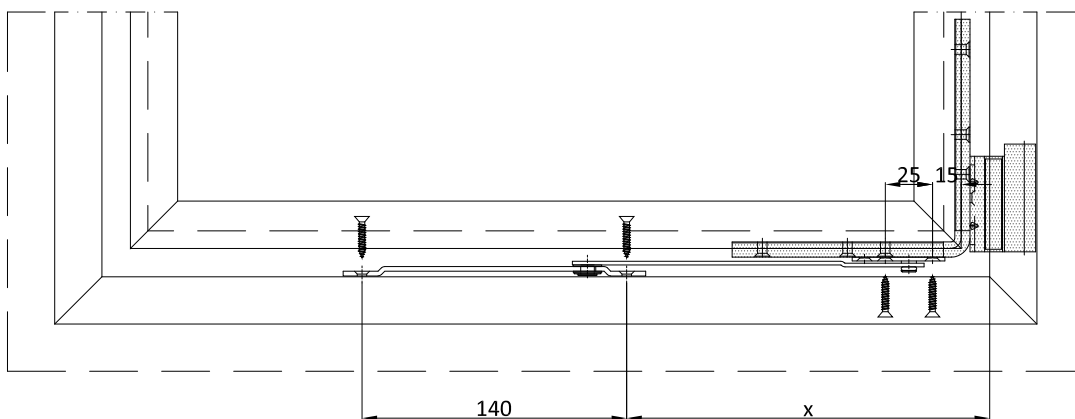
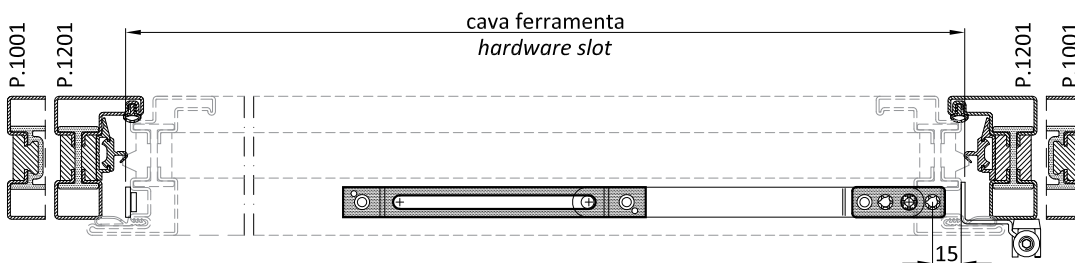
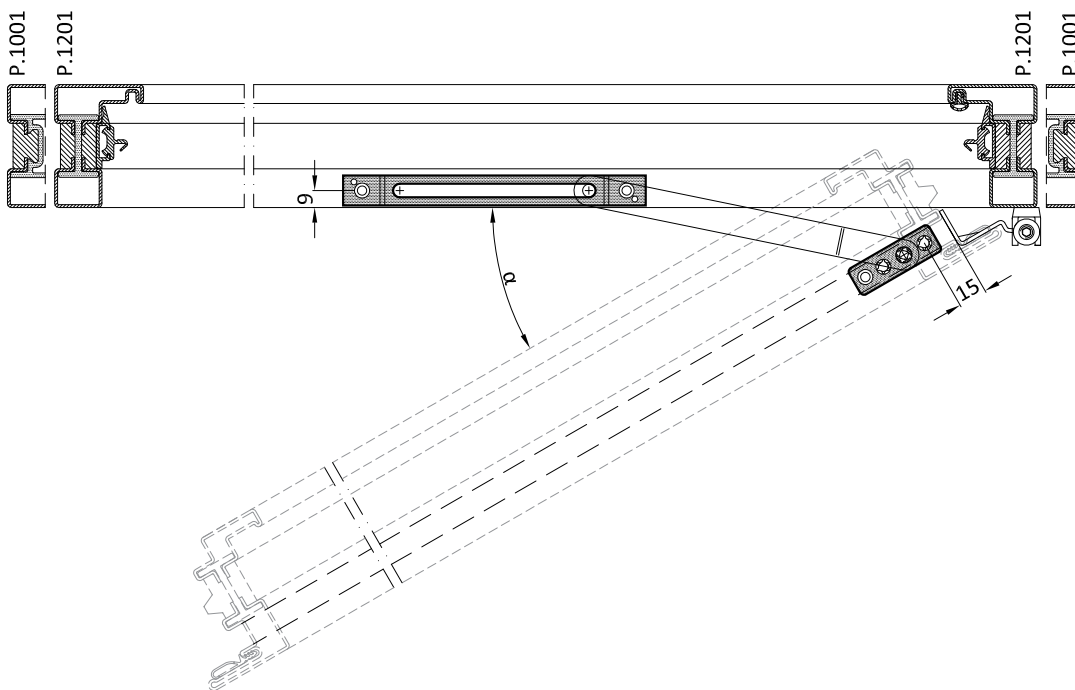
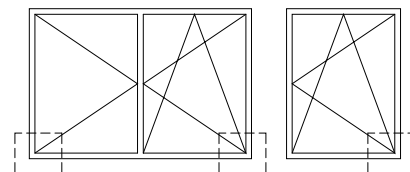

non installabile su kit AG1271-2-5-6  
not possible to install on kit AG1271-2-5-6



$\alpha$	x [mm]	min. cava ferramenta hardware slot min.	[mm]
30°	196	450	
45°	186	440	
90°	130.5	380	
100°	117.5	370	

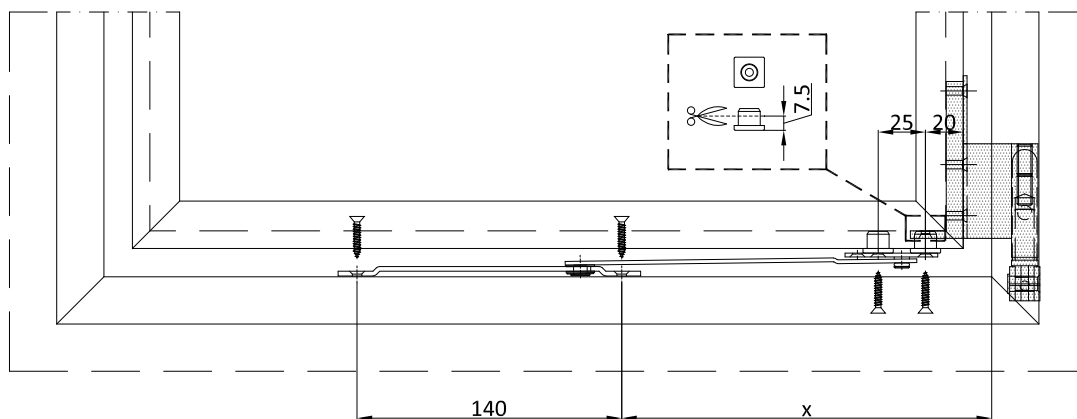
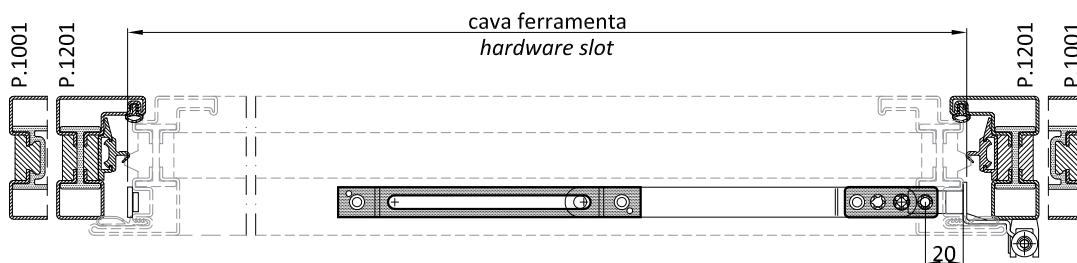
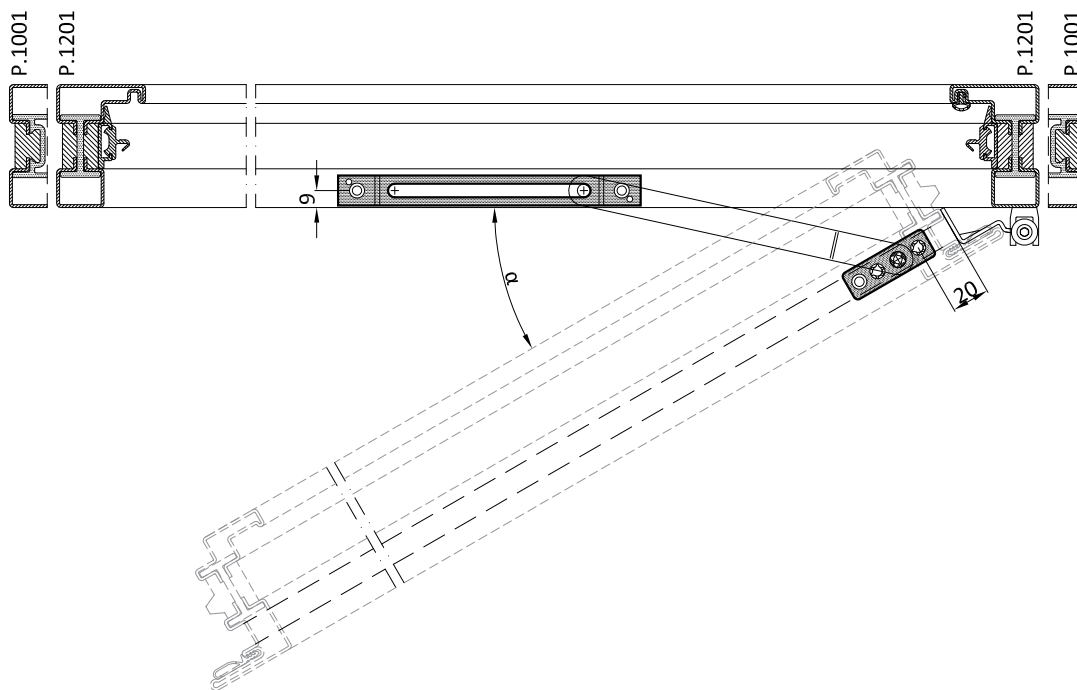
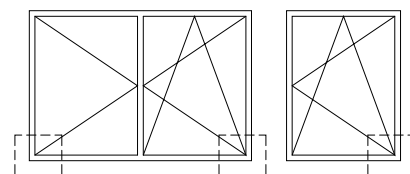

non installabile su kit AG1291-2-5-6  
not possible to install on kit AG1291-2-5-6



$\alpha$	x [mm]	y [mm]	min. cava ferramenta hardware slot min. [mm]
90°	31	16.3	450
100°	19	4.3	450

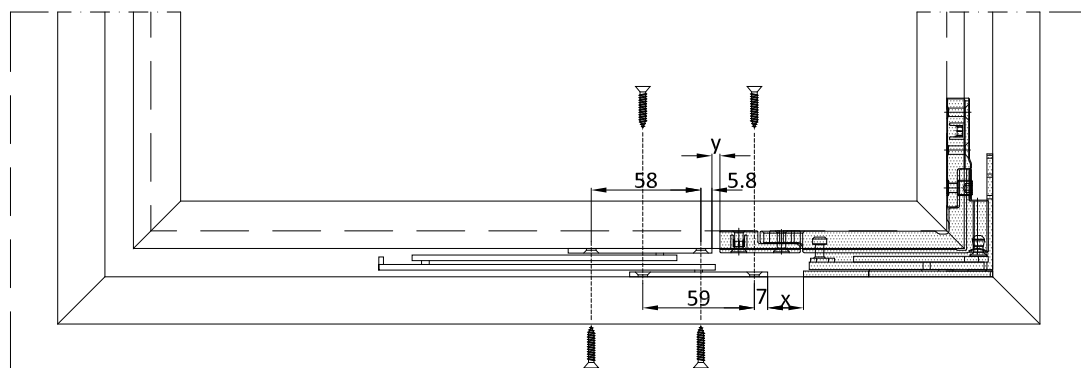
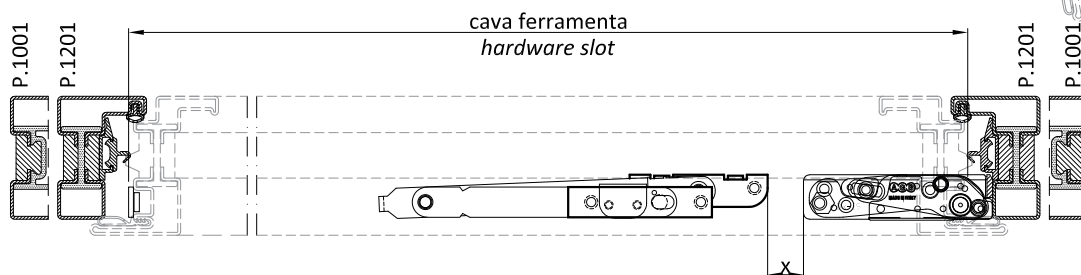
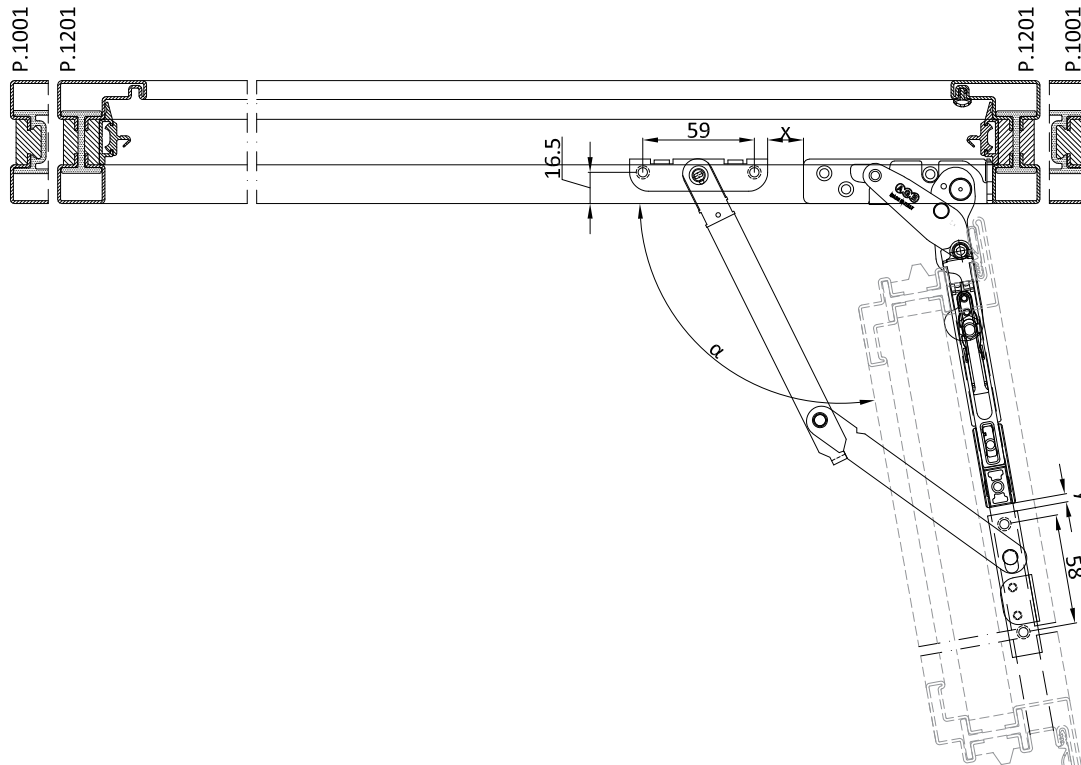
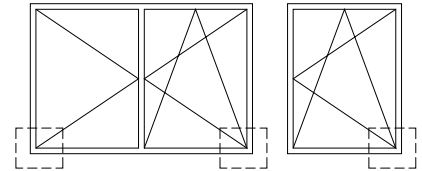

non installabile su kit AG1281-2-5-6  
not possible to install on kit AG1281-2-5-6



		H altezza - Height			
AG1264		560 660	661 860	861 1200	1201 1600
L W larghezza width	600-910	A1	B1	C1	D1
	911-1110	A2	B2	C2	D2
	1111-1470	A3	B3	C3	D3
	1471-1860	A4	B4	C4	D4

Specificare all'ordine misure cava ferramenta  
Specify hardware slot size

		H altezza - Height			
AG1274		350 660	661 860	861 1200	1201 1400
L W larghezza width	560-660	A1	B1	C1	D1
	661-860	A2	B2	C2	D2
	861-1200	A3	B3	C3	D3
	1201-1600	A4	B4	C4	D4

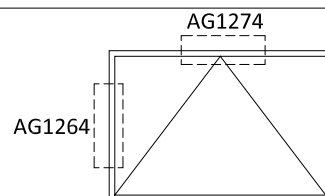

2 cerniere - peso massimo anta 70 kg  
3 cerniere - peso massimo anta 100 kg  
  
2 hinges - maximum leaf weight 70 kg  
3 hinges - maximum leaf weight 100 kg

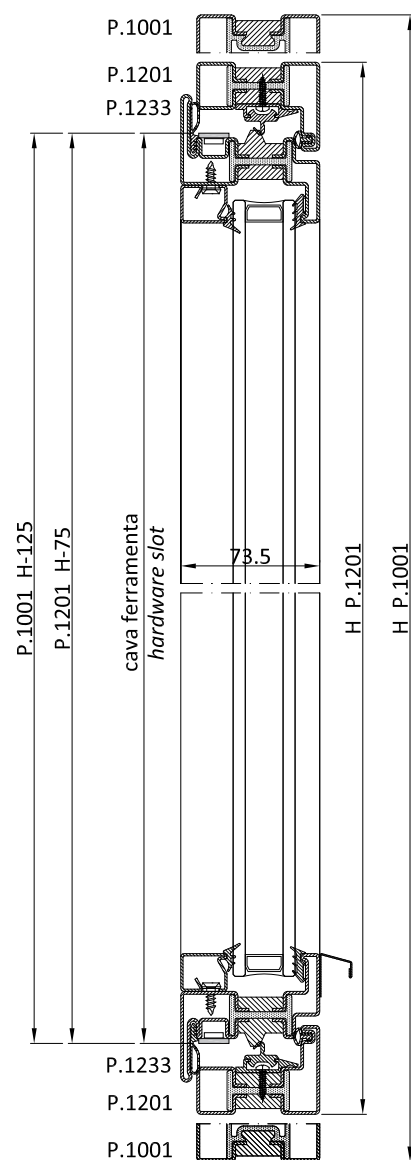
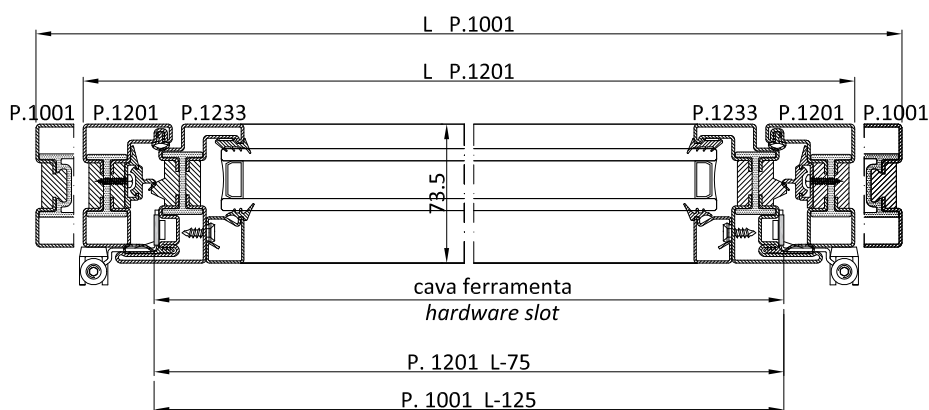



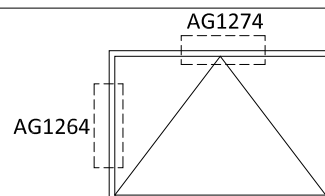

Fori per inserimento quadro comando e fissaggio maniglia / movimento DK  
holes for inserting control panel and anchoring of handle / TT (tilt and turn) movement

Asola per inserimento meccanismo cremonese  
Slot for insertion of cremone mechanism

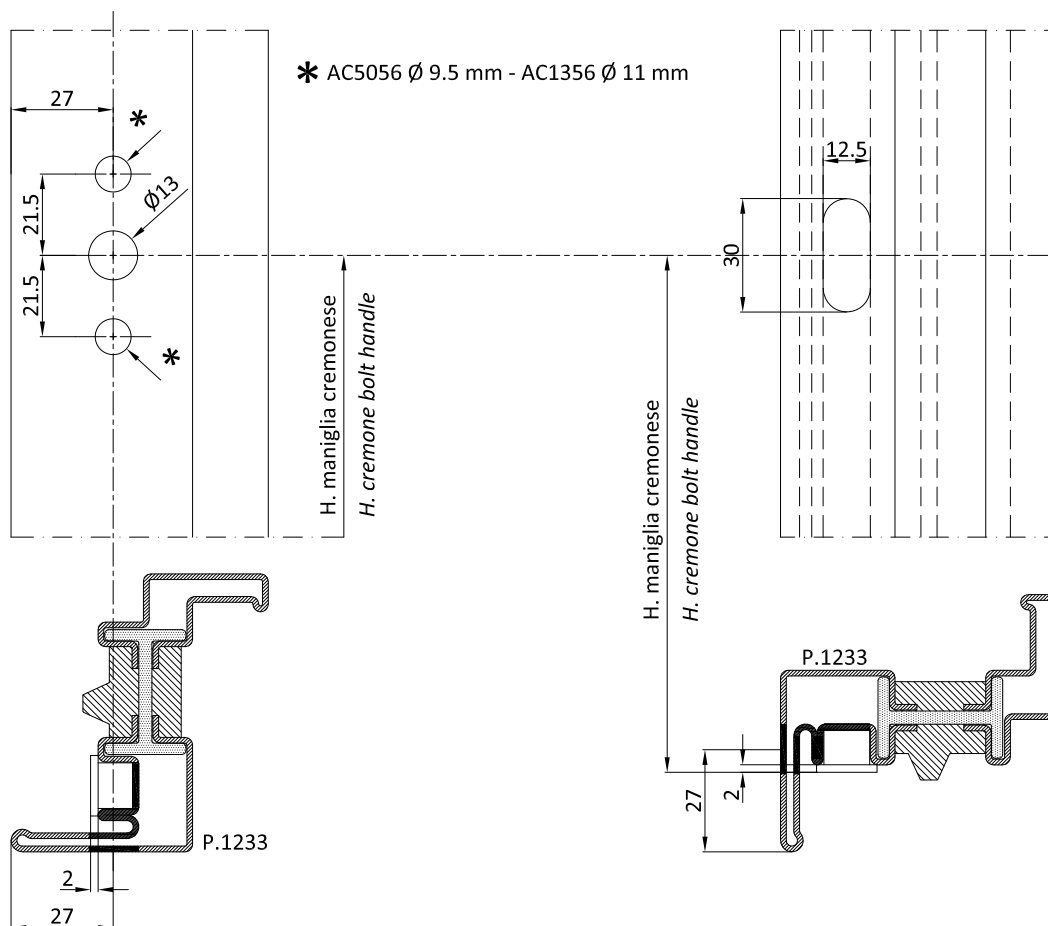

AG1264 ALTEZZA MANIGLIA CREMONESE - CREMONE BOLT HANDLE HEIGHT		
Tipo Type	cava ferramenta hardware slot	H maniglia cremonese H cremone bolt handle
Vasistas Bottom-hung	560 → 660	H/2
	661 → 860	H/2
	861 → 1200	H/2
	1201 → 1600	H/2

AG1274 ALTEZZA MANIGLIA CREMONESE - CREMONE BOLT HANDLE HEIGHT		
Tipo Type	cava ferramenta hardware slot	H maniglia cremonese H cremone bolt handle
Vasistas Bottom-hung	560 → 660	L/2
	661 → 860	L/2
	861 → 1200	L/2
	1201 → 1600	L/2

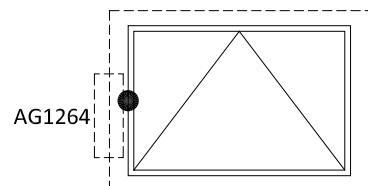

2 cerniere - peso massimo anta 70 kg  
3 cerniere - peso massimo anta 100 kg

2 hinges - maximum leaf weight 70 kg  
3 hinges - maximum leaf weight 100 kg

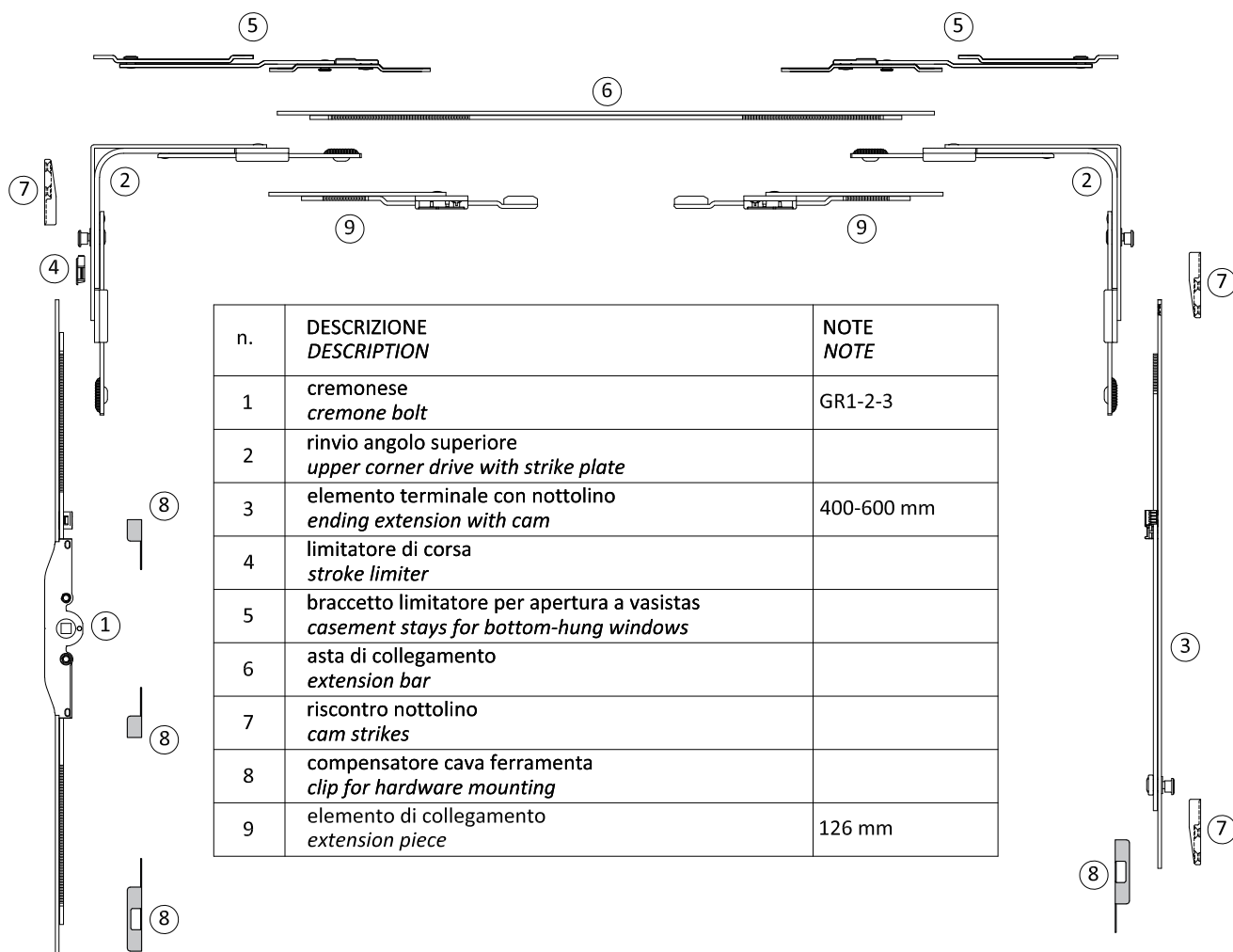

n.	DESCRIZIONE DESCRIPTION	NOTE NOTE
1	cremonese cremone bolt	GR1-2-3
2	rinvio angolo superiore upper corner drive with strike plate	
3	elemento terminale con nottolino ending extension with cam	400-600 mm
4	limitatore di corsa stroke limiter	
5	braccetto limitatore per apertura a vasistas casement stays for bottom-hung windows	
6	asta di collegamento extension bar	
7	riscontro nottolino cam strikes	
8	compensatore cava ferramenta clip for hardware mounting	
9	elemento di collegamento extension piece	126 mm

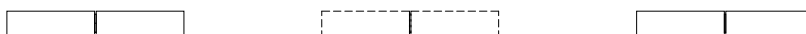

AC1221  
AC2632/C  
AG1224

cerniere non incluse nel kit  
hinges not included in the kit

Specificare all'ordine misure cava ferramenta  
Specify hardware slot size



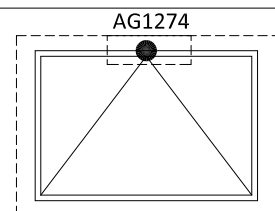

2 cerniere - peso massimo anta 70 kg  
3 cerniere - peso massimo anta 100 kg

2 hinges - maximum leaf weight 70 kg  
3 hinges - maximum leaf weight 100 kg

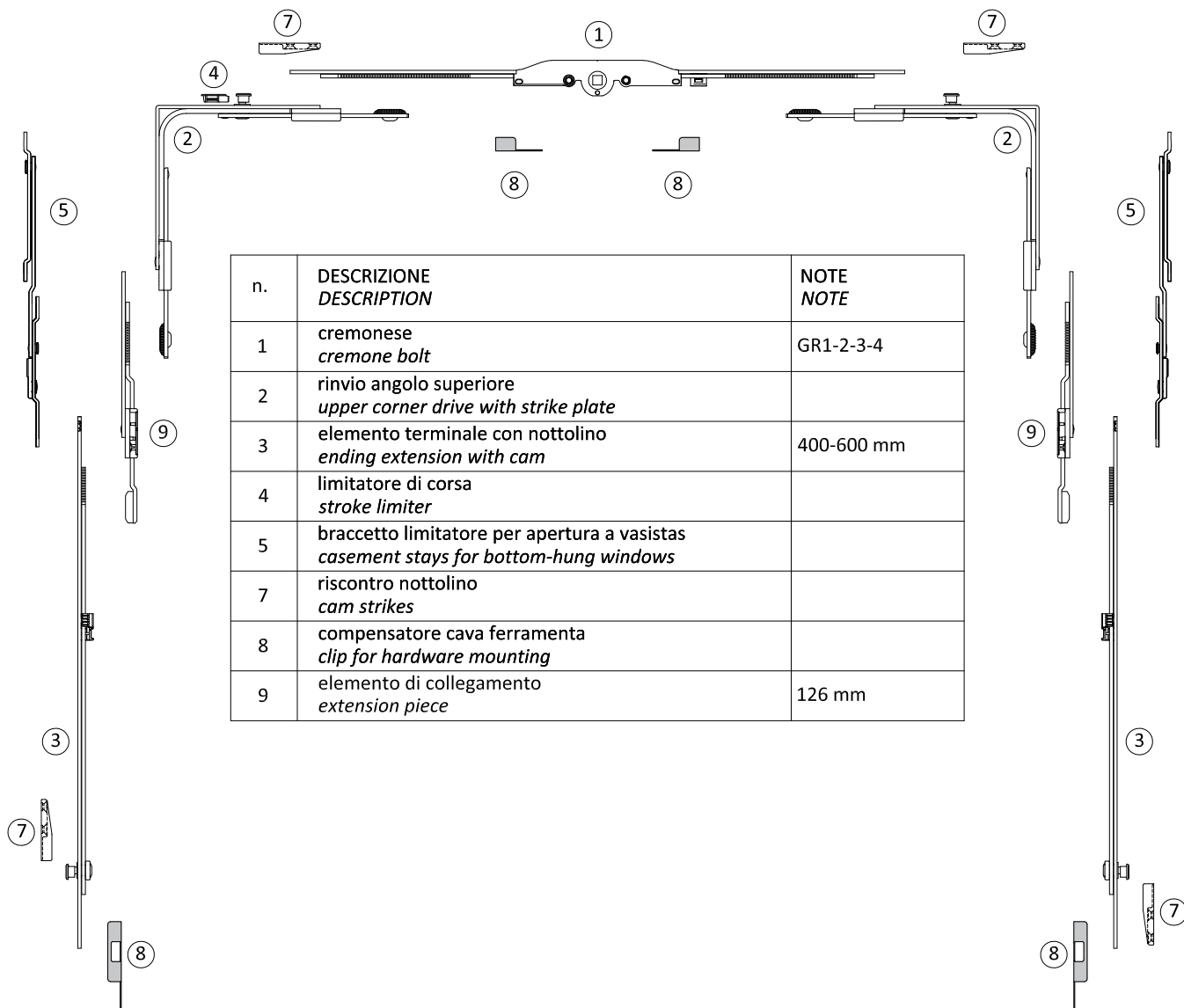

n.	DESCRIZIONE DESCRIPTION	NOTE NOTE
1	cremonese cremone bolt	GR1-2-3-4
2	rinvio angolo superiore upper corner drive with strike plate	
3	elemento terminale con nottolino ending extension with cam	400-600 mm
4	limitatore di corsa stroke limiter	
5	braccetto limitatore per apertura a vasistas casement stays for bottom-hung windows	
7	riscontro nottolino cam strikes	
8	compensatore cava ferramenta clip for hardware mounting	
9	elemento di collegamento extension piece	126 mm

AC1221  
AC2632/C  
AG1224

cerniere non incluse nel kit  
hinges not included in the kit



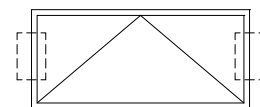
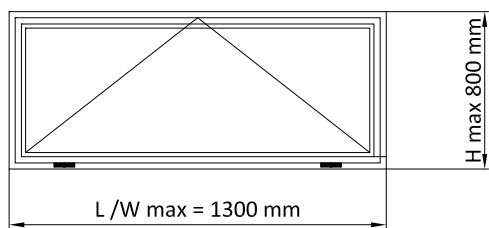

Peso max. per anta 70 Kg  
H min anta 300 mm  
Max. weight for leaf: 70 kg  
W min leaf 300 mm

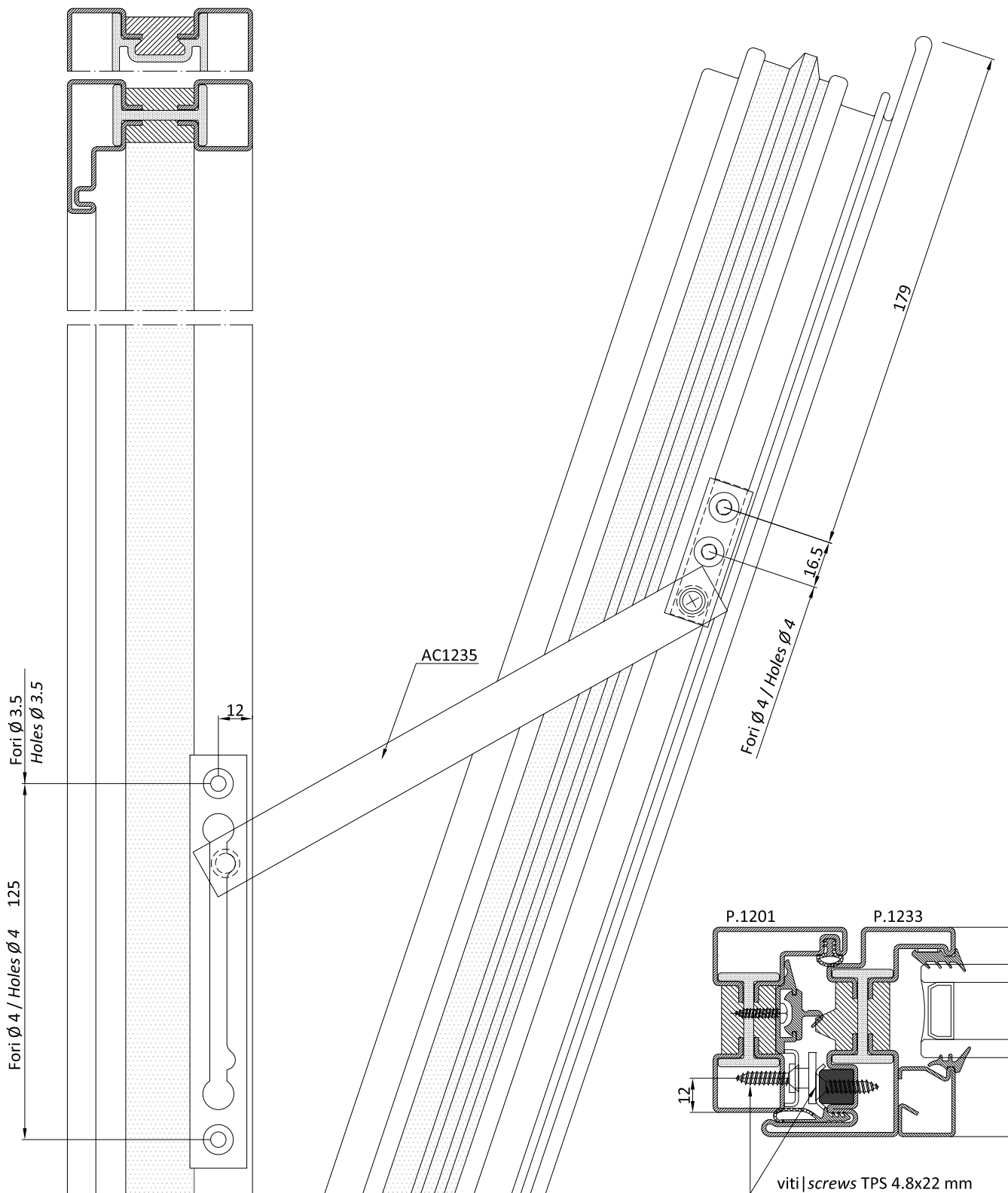

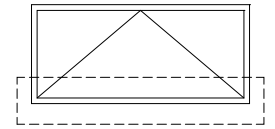
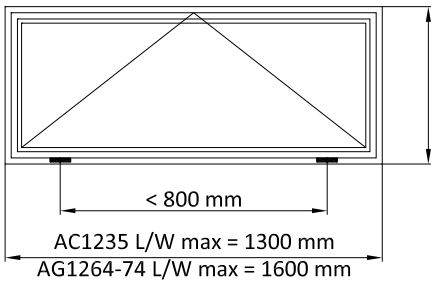

AC1235  
Peso max. per anta 70 kg  
Max. weight for leaf: 70 kg

AG1264 - AG1274  
2 cerniere  
peso massimo anta 70 kg  
3 cerniere  
peso massimo anta 100 kg

2 hinges  
maximum leaf weight 70 kg  
3 hinges  
maximum leaf weight 100 kg

GE1200TT - tagliare la guarnizione dove interseca le cerniere  
GE1200TT - cut the gasket where the hinges cross

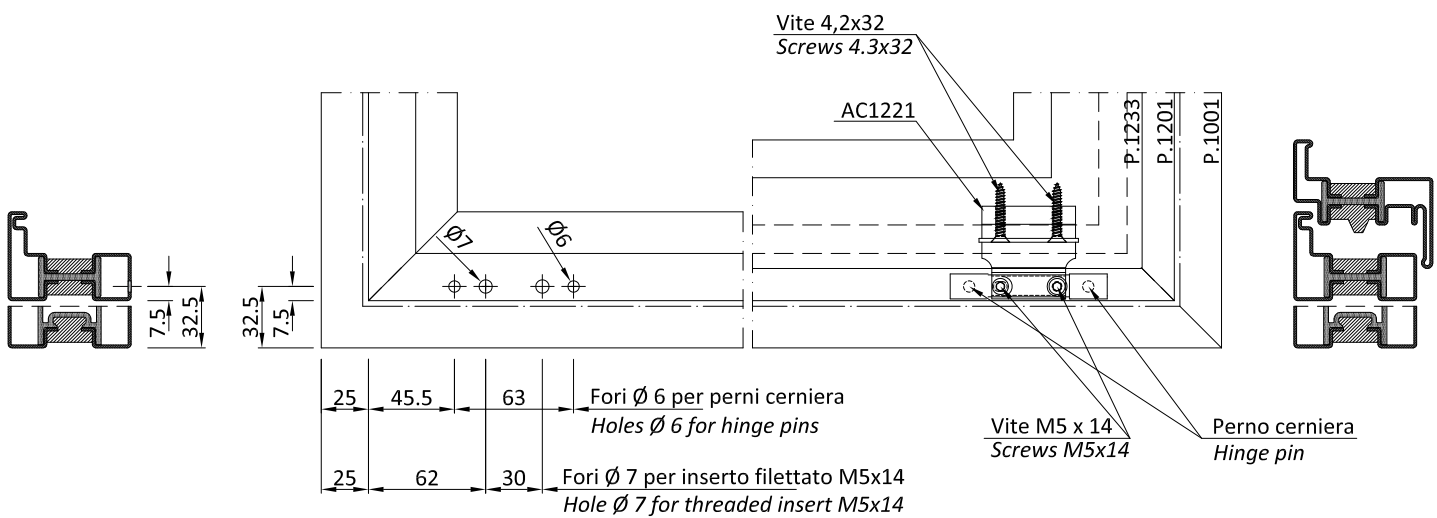
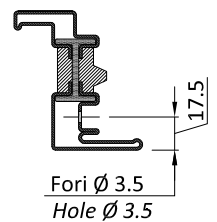
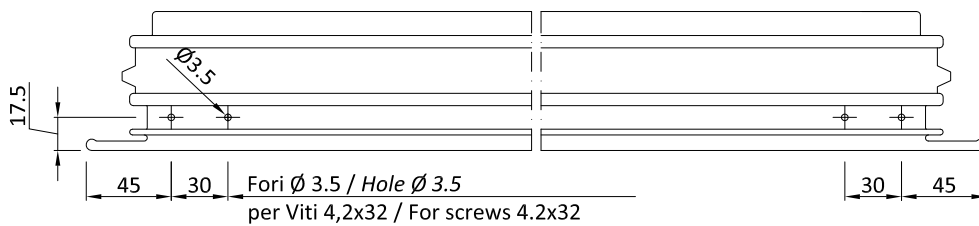
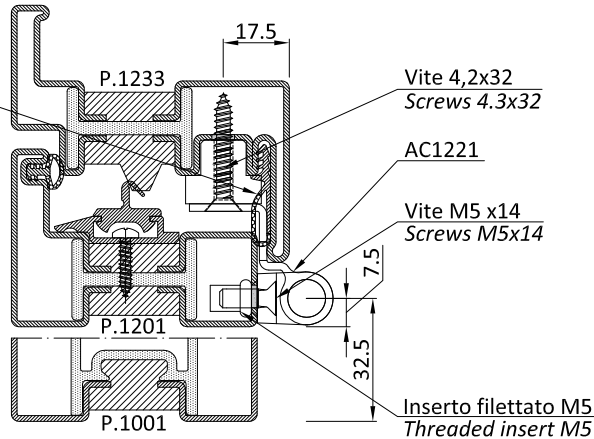

Viti non fornite  
Screws not supplied



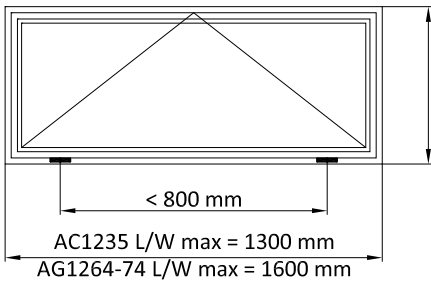

AC1235 H max = 800 mm  
AG1264-74 H max = 1200 mm

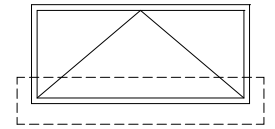

AC1235  
Peso max. per anta 70 kg  
Max. weight for leaf: 70 kg

AG1264 - AG1274  
2 cerniere  
peso massimo anta 70 kg  
3 cerniere  
peso massimo anta 100 kg

2 hinges  
maximum leaf weight 70 kg  
3 hinges  
maximum leaf weight 100 kg

GE1200TT - tagliare la guarnizione dove interseca le cerniere  
GE1200TT - cut the gasket where the hinges cross

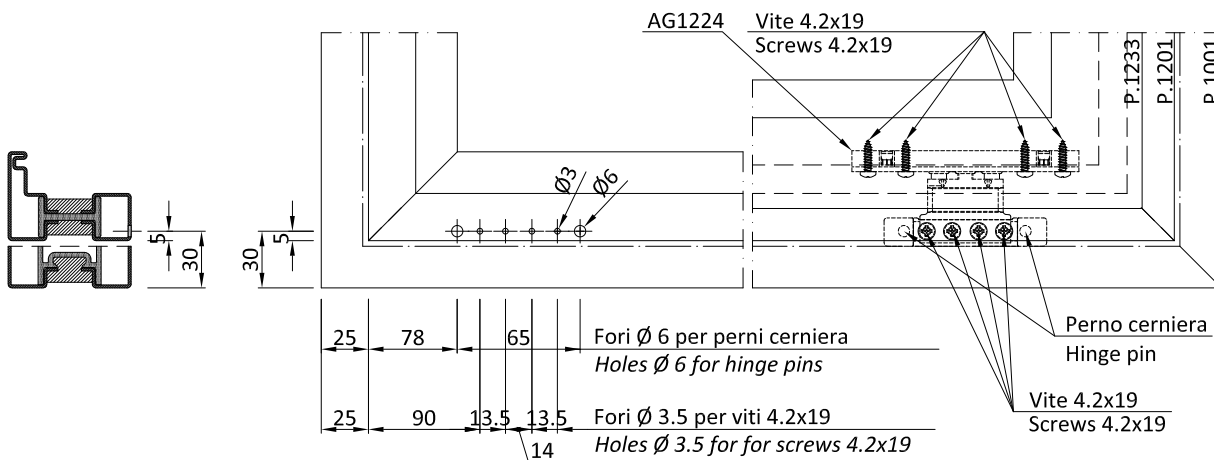
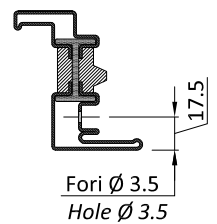
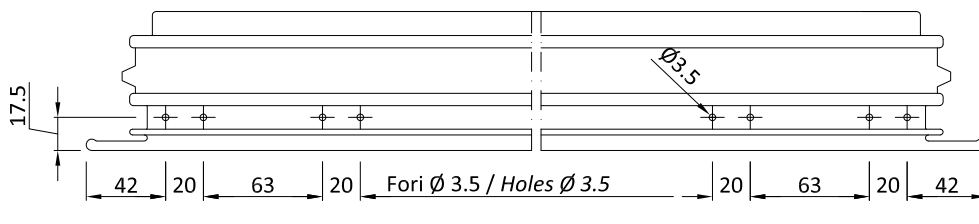
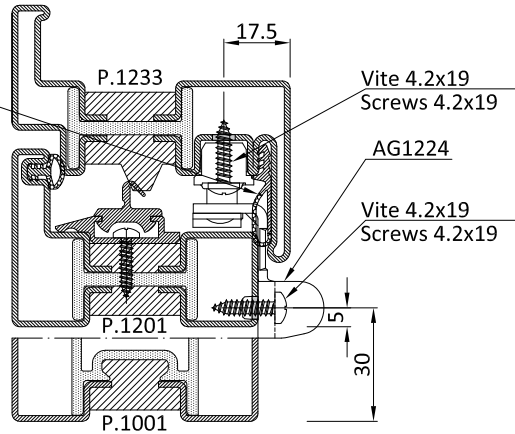

Viti non fornite  
Screws not supplied



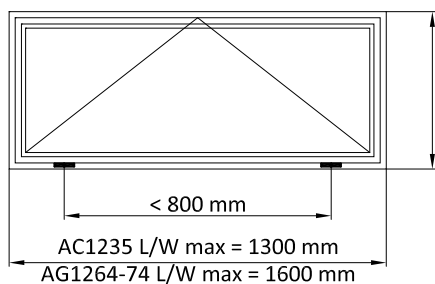

AC1235 H max = 800 mm  
AG1264-74 H max = 1200 mm

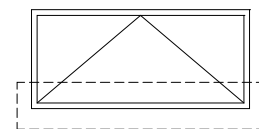

AC1235  
Peso max. per anta 70 kg  
Max. weight for leaf: 70 kg

AG1264 - AG1274  
2 cerniere  
peso massimo anta 70 kg  
3 cerniere  
peso massimo anta 100 kg

2 hinges  
maximum leaf weight 70 kg  
3 hinges  
maximum leaf weight 100 kg

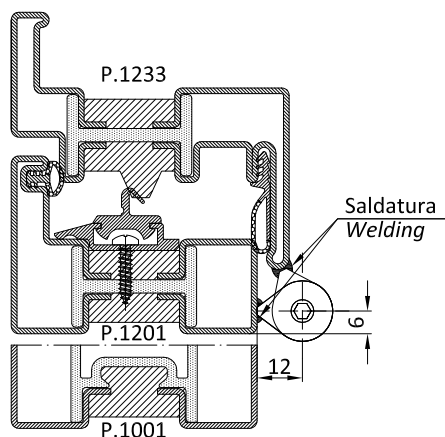

Posizionare le cerniere come da disegno saldandole sui alti.  
Position the hinges as in the drawing, welding them on the sides.

- La lavorazione può essere effettuata anche in posizioni intermedie alla larghezza del vasistas.
- La lavorazione SX è speculare alla DX.
- Tooling can be carried out also in intermediate positions regarding the width of the hopper or bottom-hung window.
- Tooling on left is the same as that on the right.

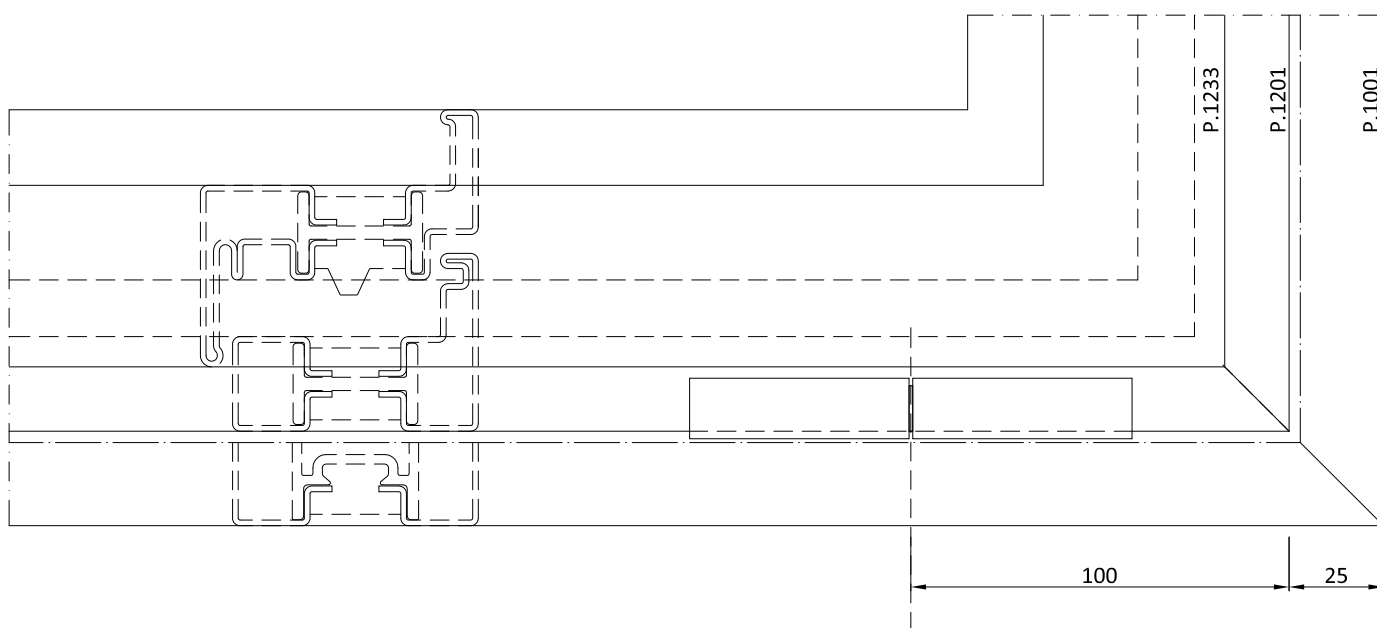

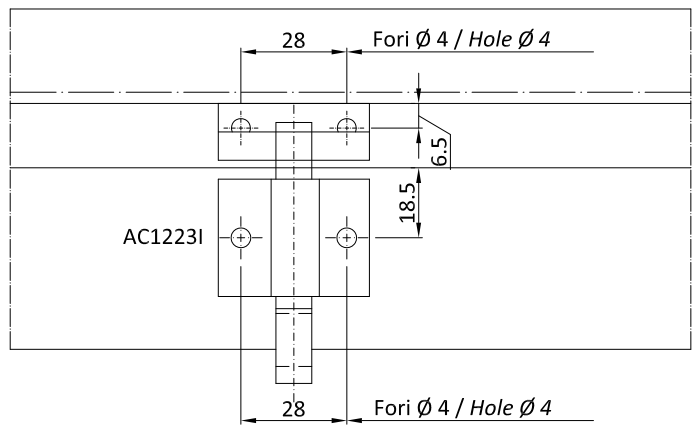
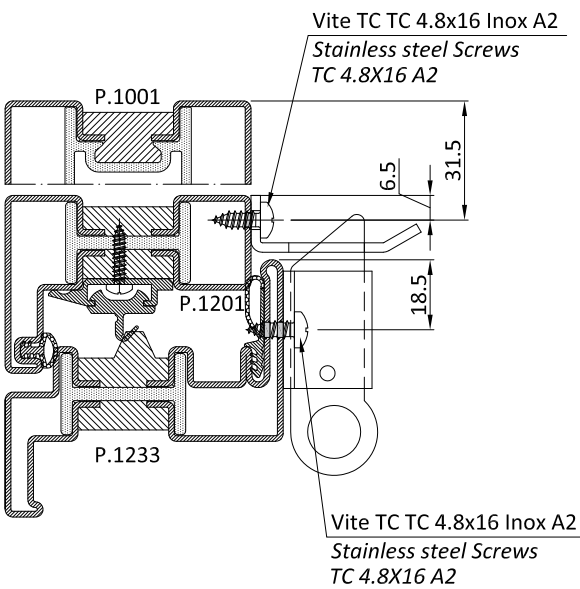
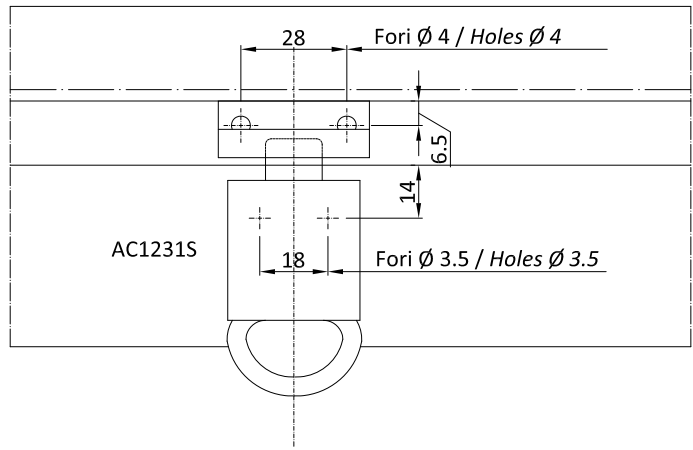
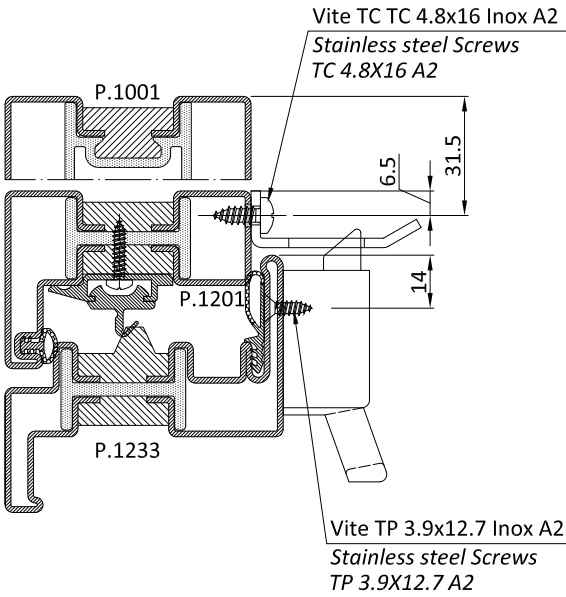
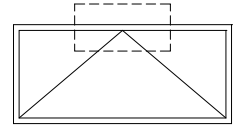
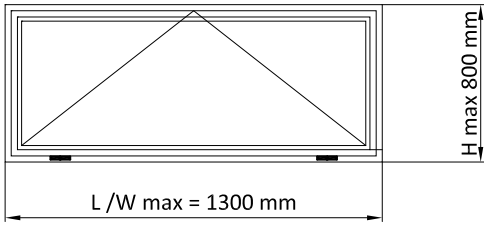



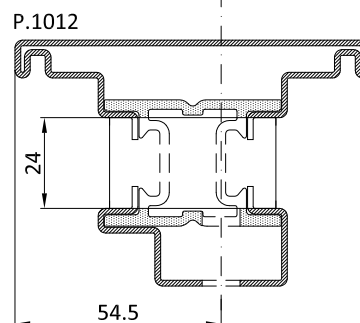
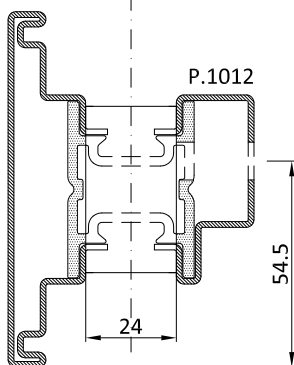
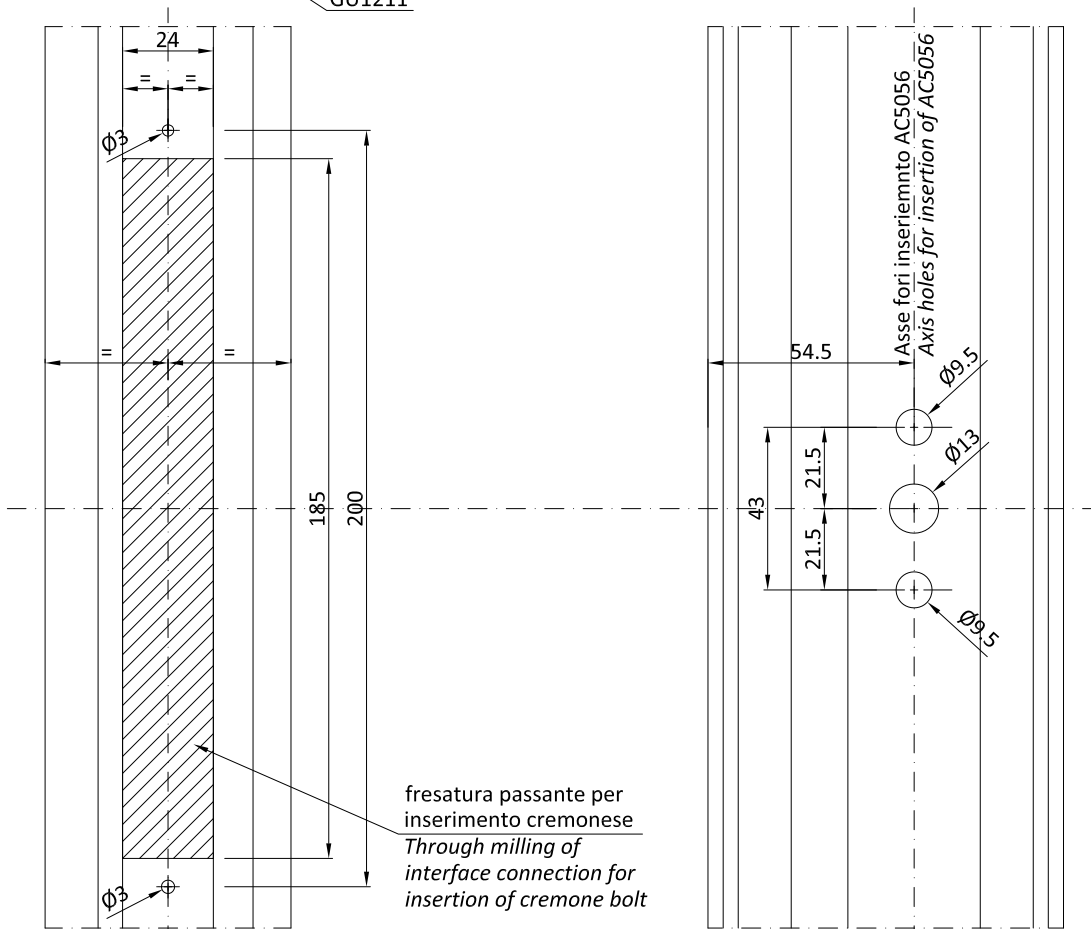
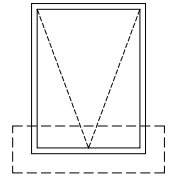
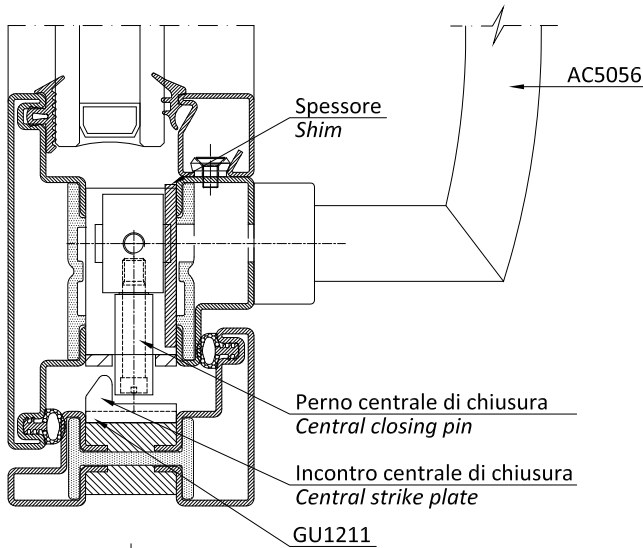

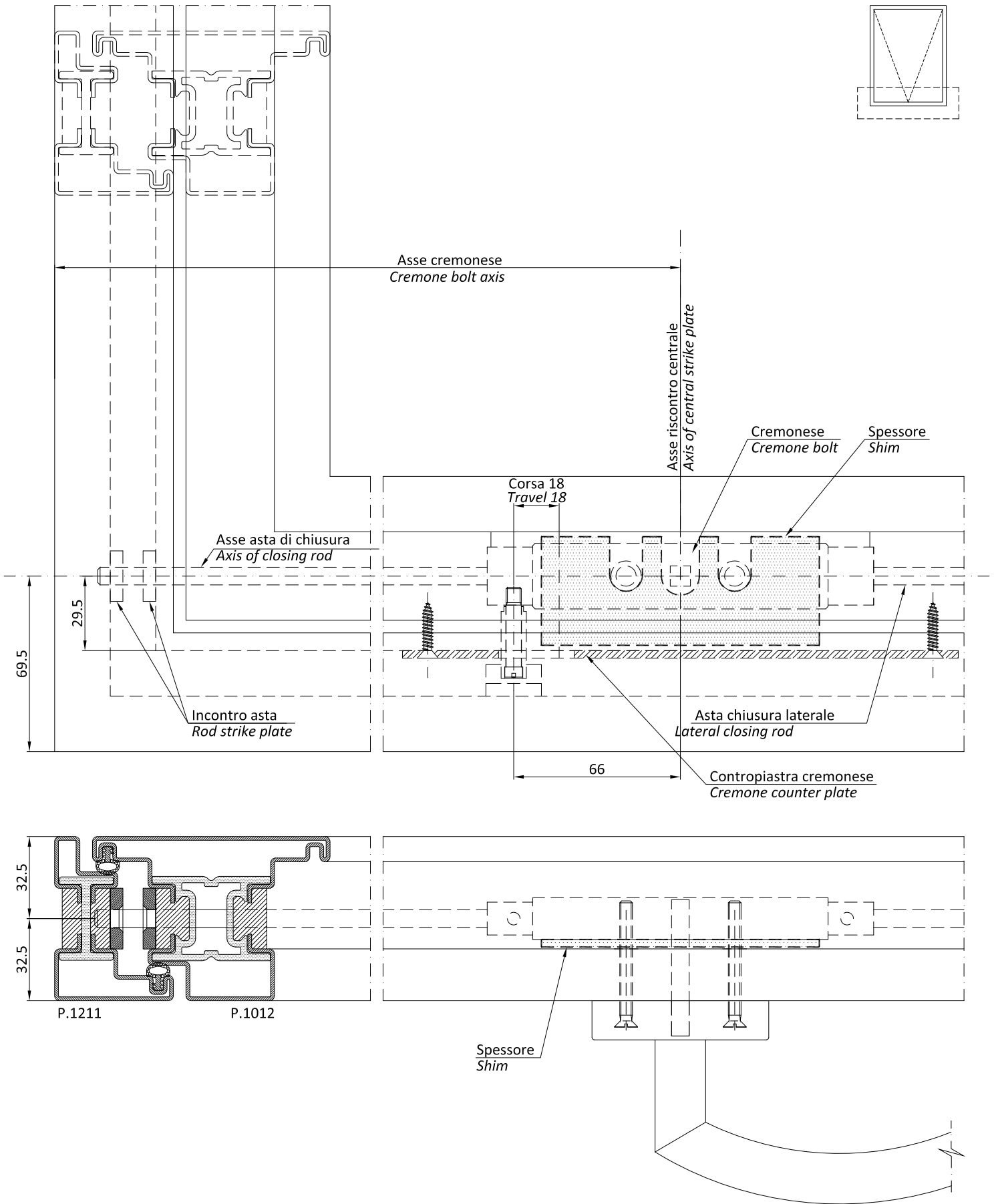

Peso massimo anta 75 kg  
Maximum vent weight 75 kg

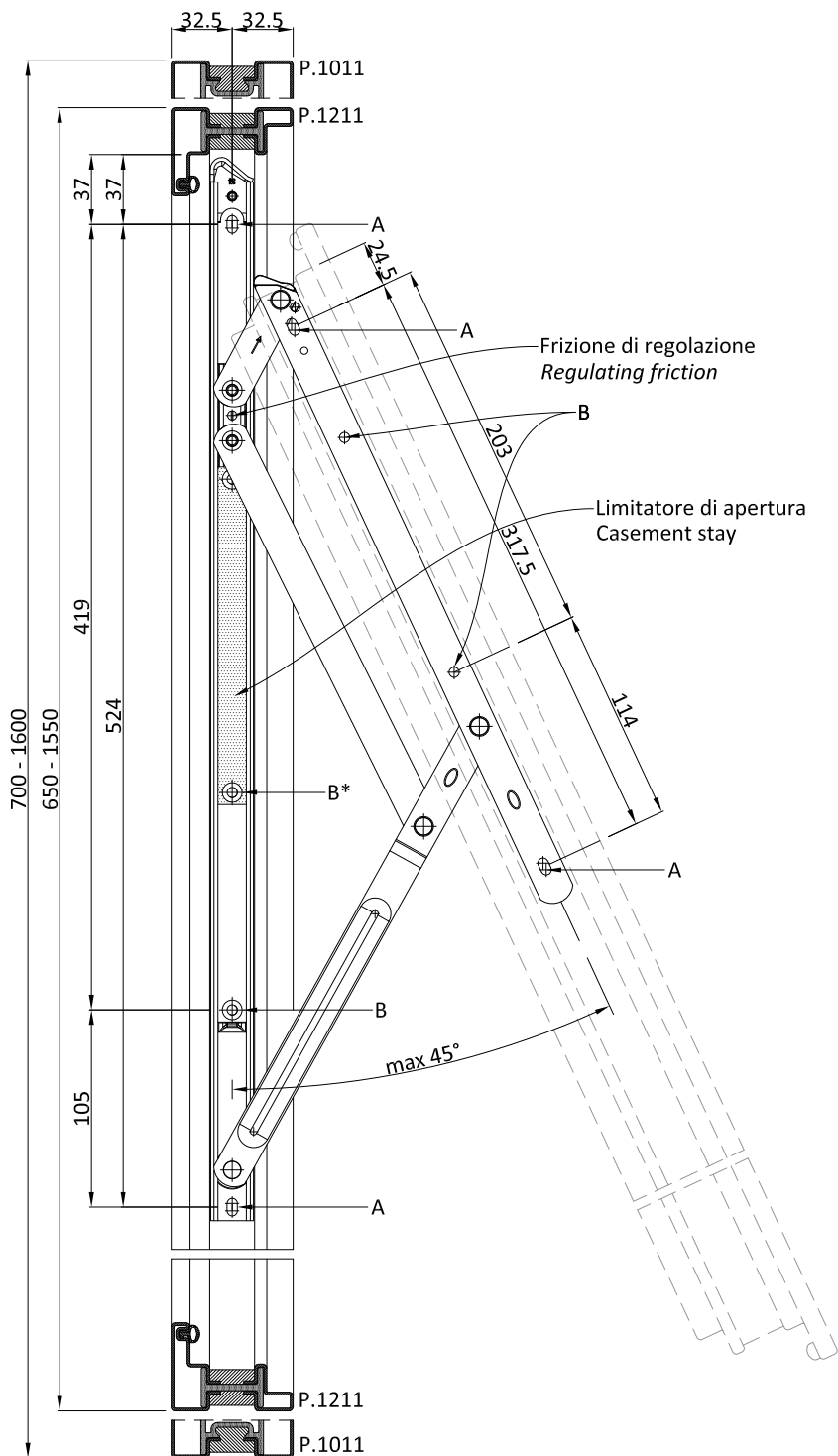
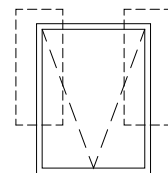

- Fissare i compassi in corrispondenza dei fori asolati A foro su profilo Ø 4 per viti TC 4.8x22 mm;
- Verificare il funzionamento dei compassi;
- Fissare l'apertura massima desiderata mediante il limitatore di apertura;
- Completare l'operazione di fissaggio nei rimanenti fori B.

\* posizione determinata dalla apertura massima desiderata - foro da eseguire in opera

- Fit the side arms into the slotted holes A - hole on profile Ø 4 for TC 4.8x22 mm screws;
- Check the side arms move properly;
- Set the desired maximum opening using the casement stay;
- Complete the anchoring operation in the remaining B holes.

\* Position determined by the maximum opening desired - hole to be made during installation

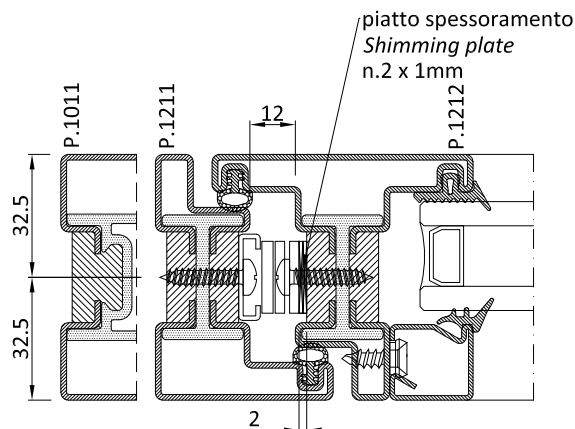

Peso massimo anta 120 kg  
Maximum vent weight 120 kg

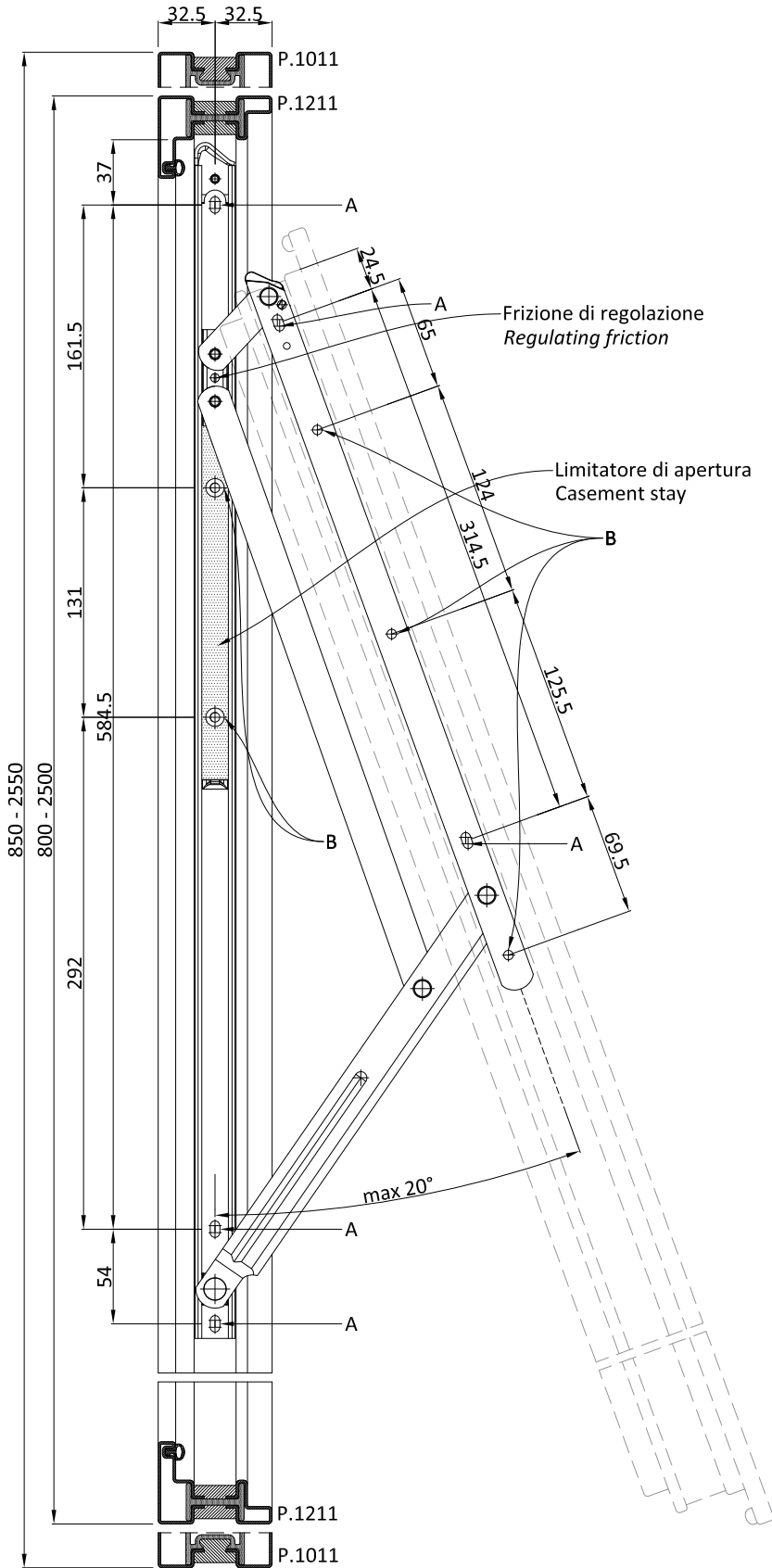
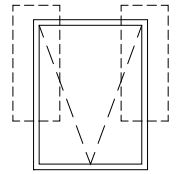

- Fissare i compassi in corrispondenza dei fori asolati A foro su profilo Ø 4 per viti TC 4.8x22 mm;
- Verificare il funzionamento dei compassi;
- Fissare l'apertura massima desiderata mediante il limitatore di apertura;
- Completare l'operazione di fissaggio nei rimanenti fori B.

\* posizione determinata dalla apertura massima desiderata - foro da eseguire in opera

- Fit the side arms into the slotted holes A - hole on profile Ø 4 for TC 4.8x22 mm screws;
- Check the side arms move properly;
- Set the desired maximum opening using the casement stay;
- Complete the anchoring operation in the remaining B holes.

\* Position determined by the maximum opening desired - hole to be made during installation

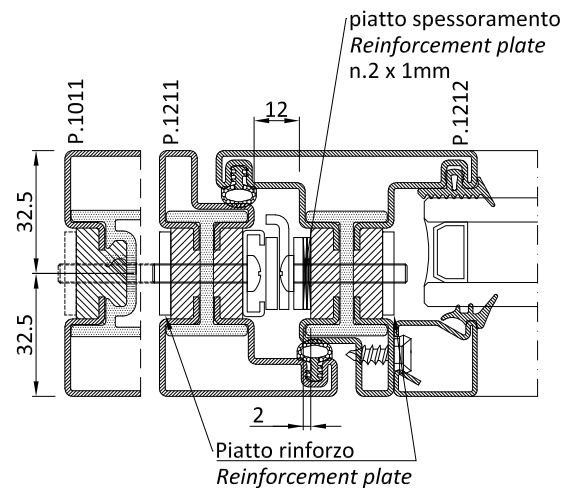

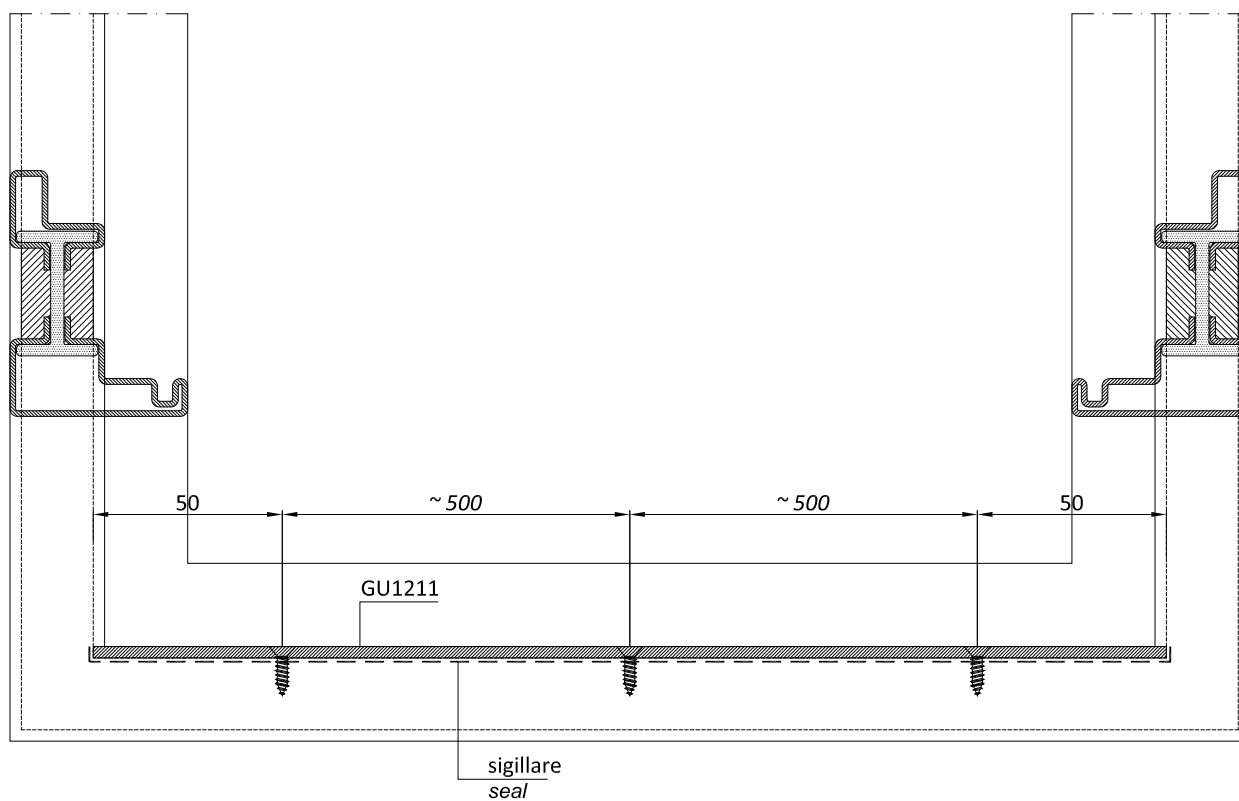
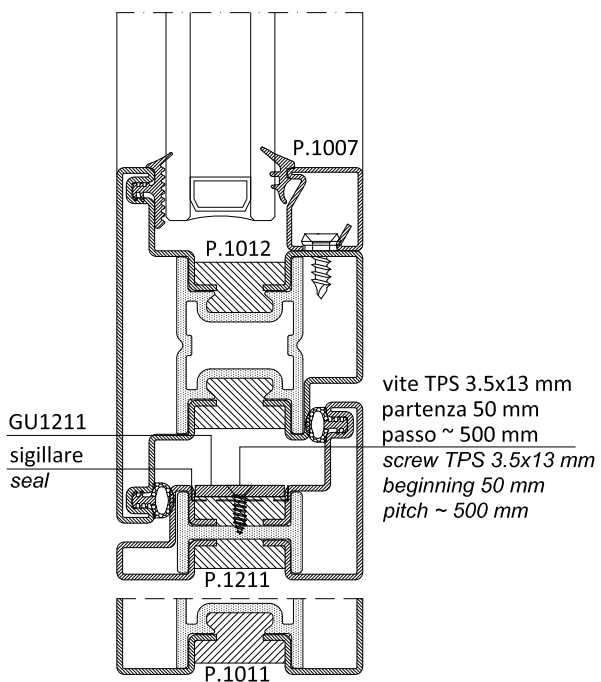
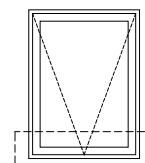

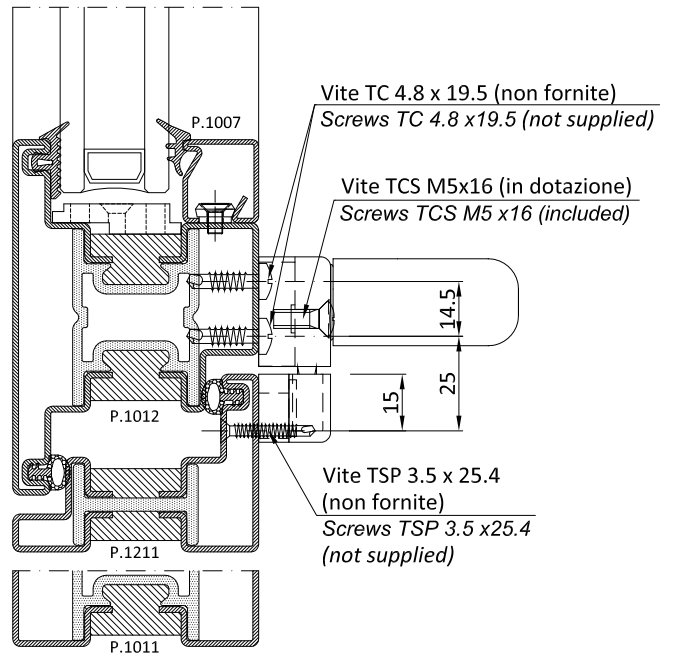
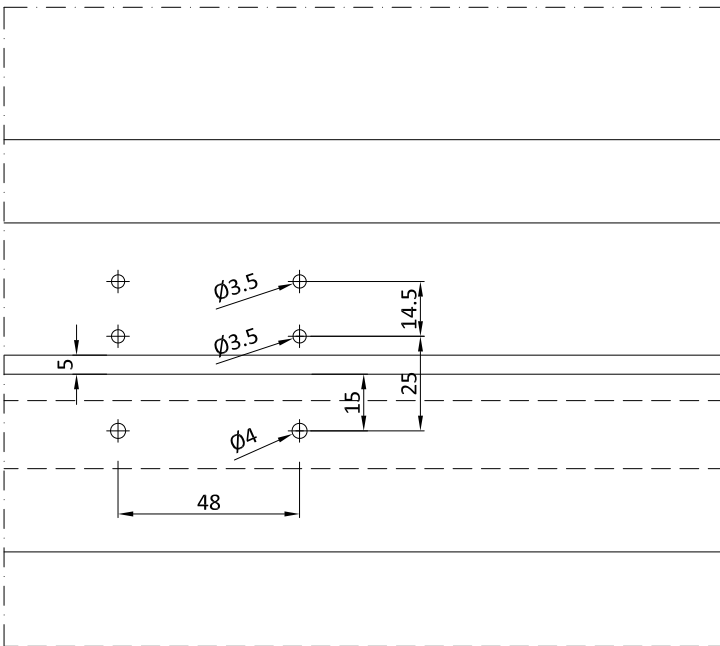
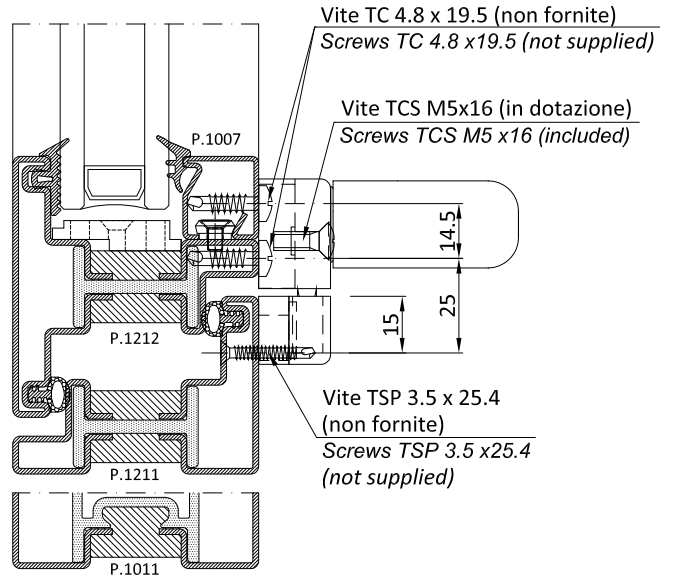
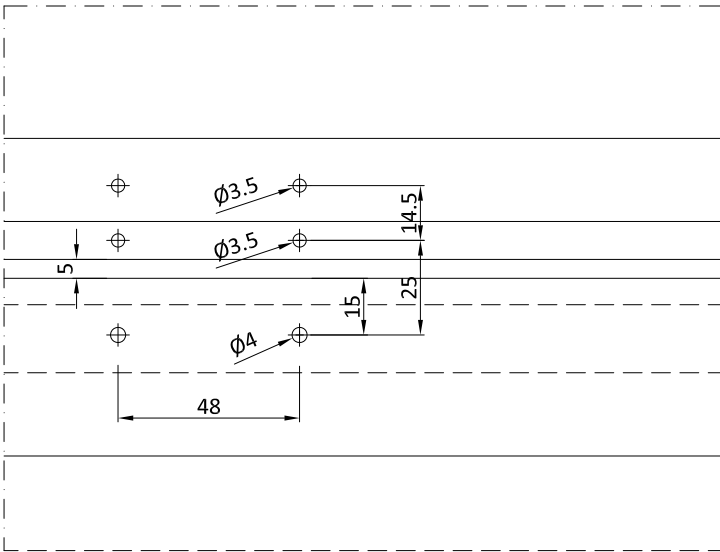
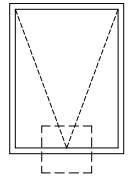
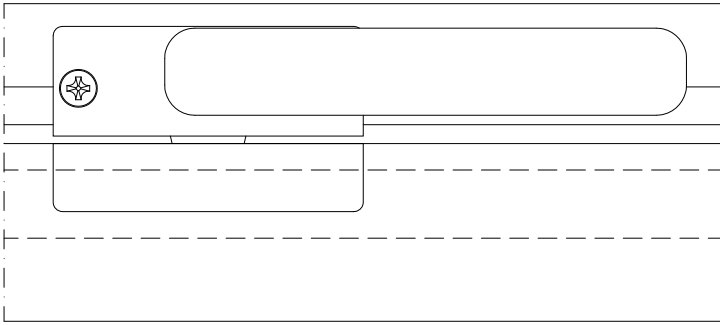

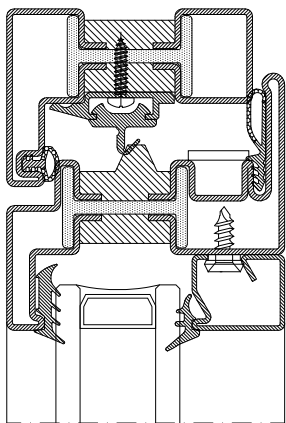
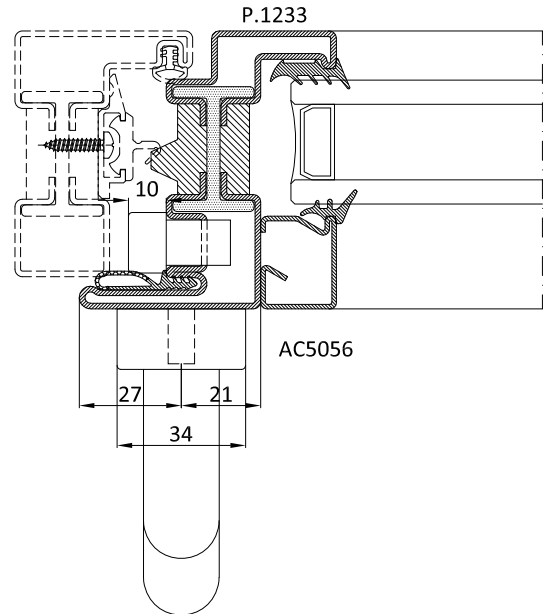
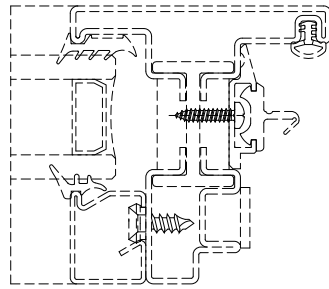
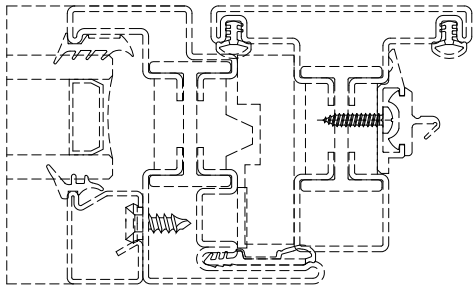
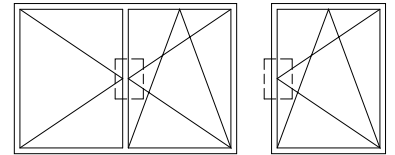

AC5056 :

- 1) Impugnatura
- 2) Rosetta
- 3) Corpo maniglia
- 4) Quadro
- 5) Vite TP M5x50 (non fornite)

AC5056 :

- 1) Handle grip
- 2) Rose
- 3) Handle body
- 4) Spindle bar
- 5) Flat head screws M5x50 (not supplied)

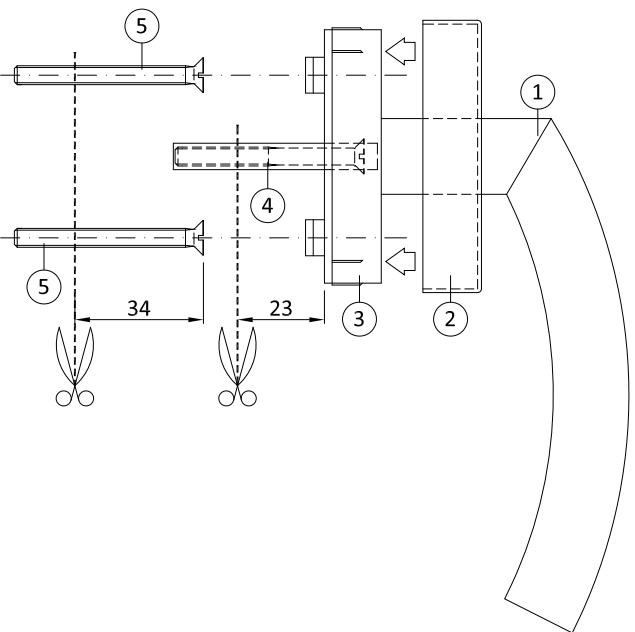
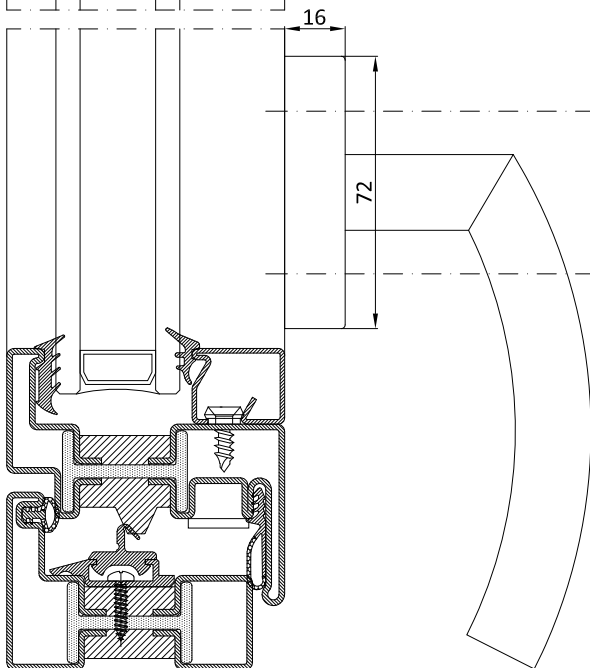

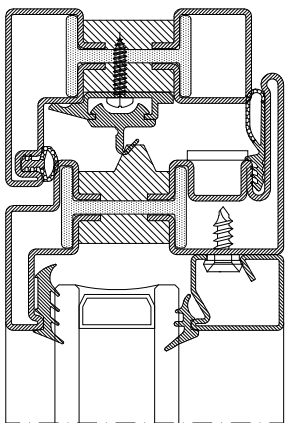
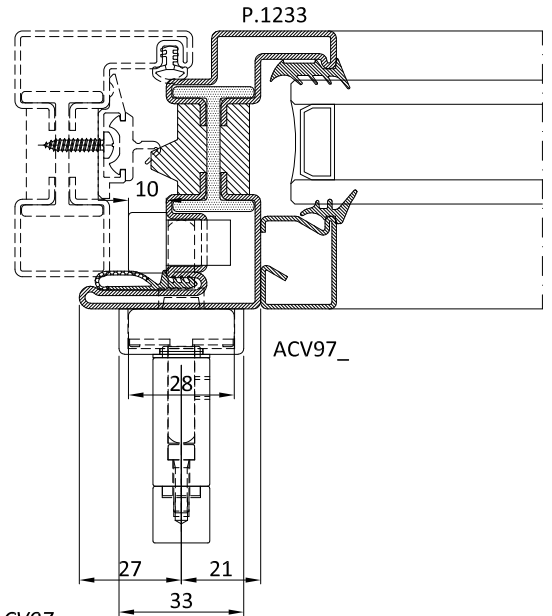
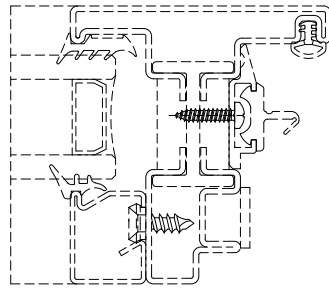
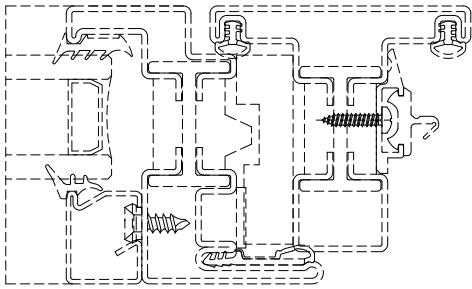
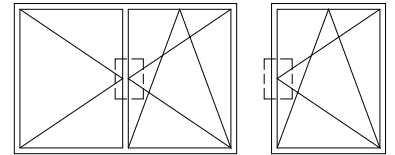

ACV97- :

- 1) Impugnatura
- 2) Rondella
- 3) Rosetta
- 4) Grano M6x6
- 5) Vite TP M5x50 (non fornite)
- 6) AC1356 Movimento DK

ACV97- :

- 1) Handle grip
- 2) Ring
- 3) Rose
- 4) Dowel M6x6
- 5) Flat head screws M5x50 (not supplied)
- 6) Tilt-turn movement AC1356

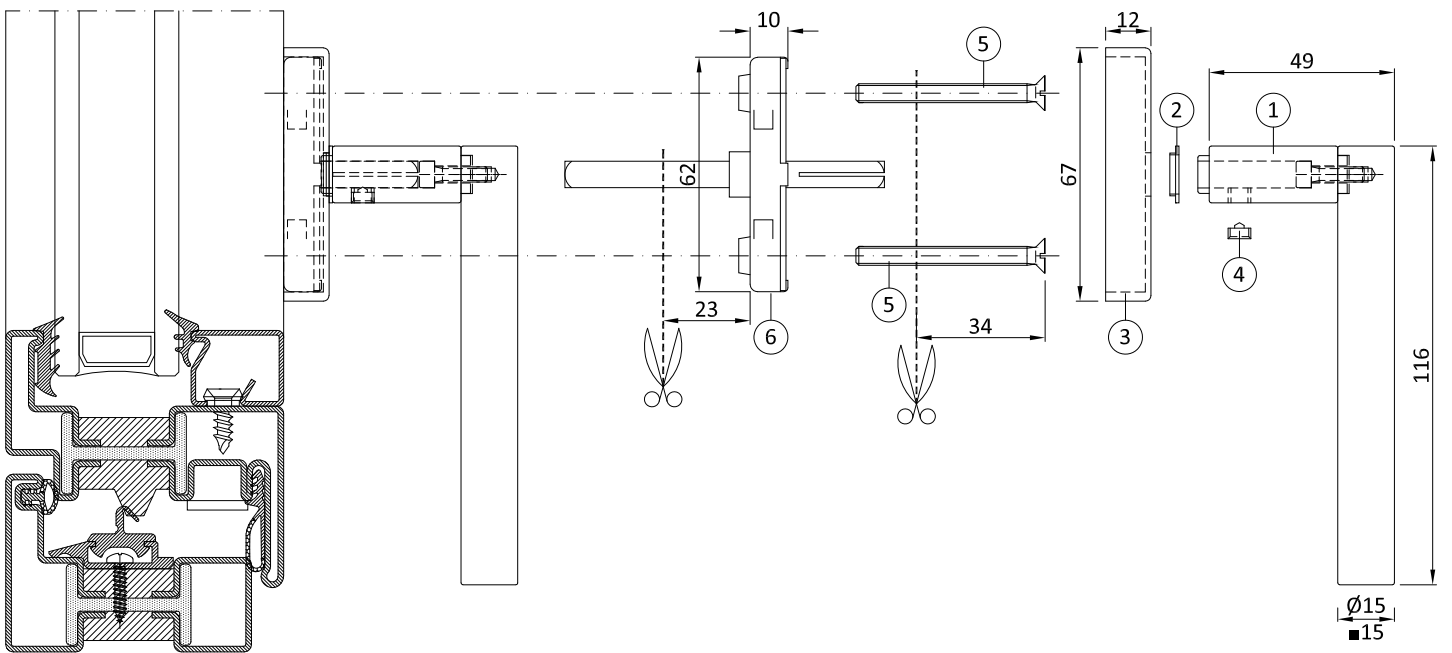



Finestra | Window

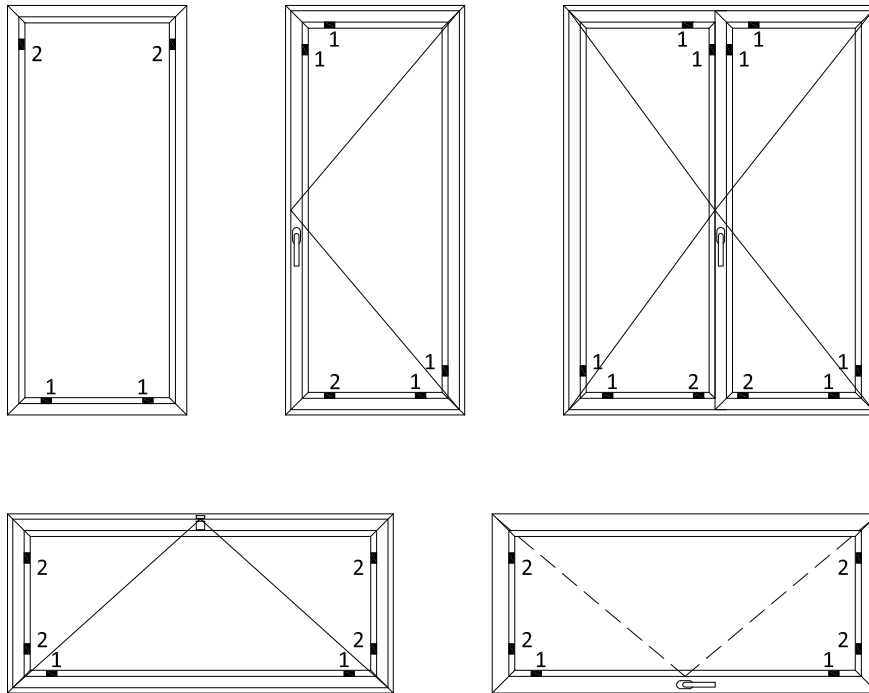

- 1) spessore portante | carry shim
- 2) spessore distanziatore | compensation shim

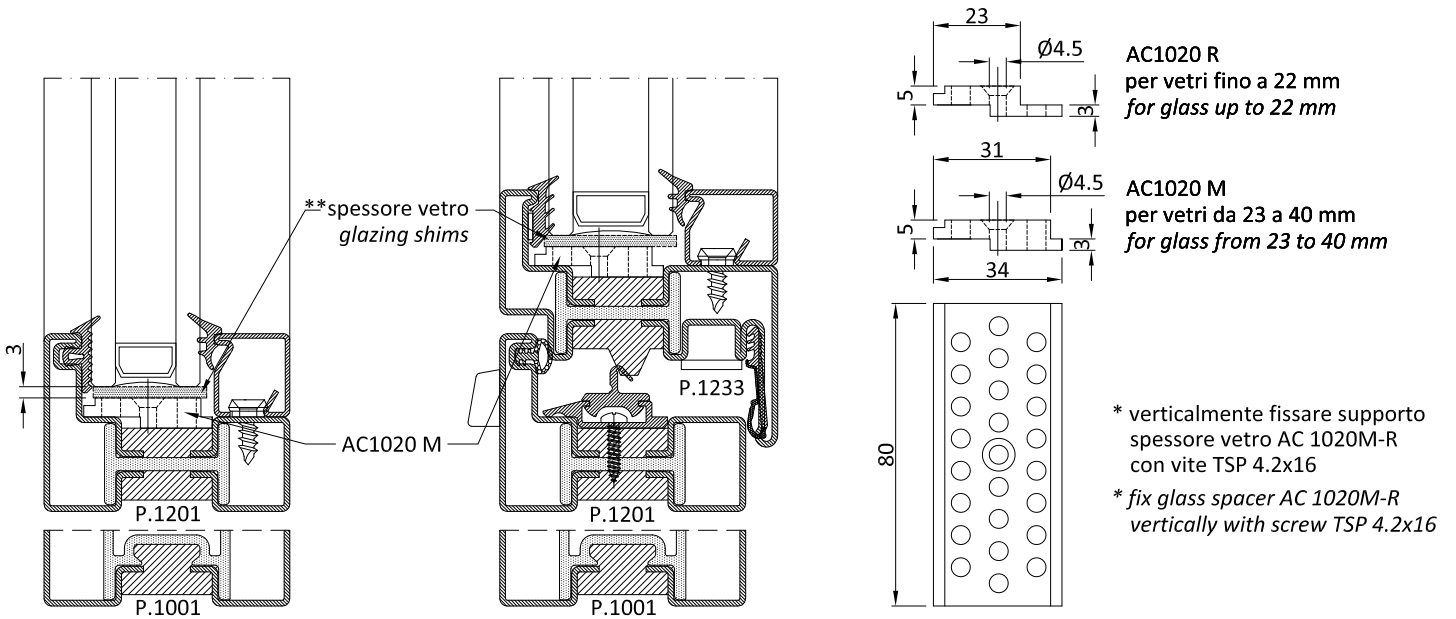

Note / Note

- La larghezza degli spessori è almeno pari o maggiore (+2 mm) dello spessore del vetro installato.
- La posizione degli spessori deve essere garantita dall'utilizzo di materiale adeguato che ne eviti lo spostamento.
- The shims' width is the same or greater (+2 mm) than the thickness of the glass installed.
- The position of the shims has to be ensured by using appropriate material that avoids creeping.

\* vite TSP 4.2 x 16 mm non inclusa - screw TSP 4.2 x 16 mm not included

\*\* spessori vetro non inclusi - glass thickness not included

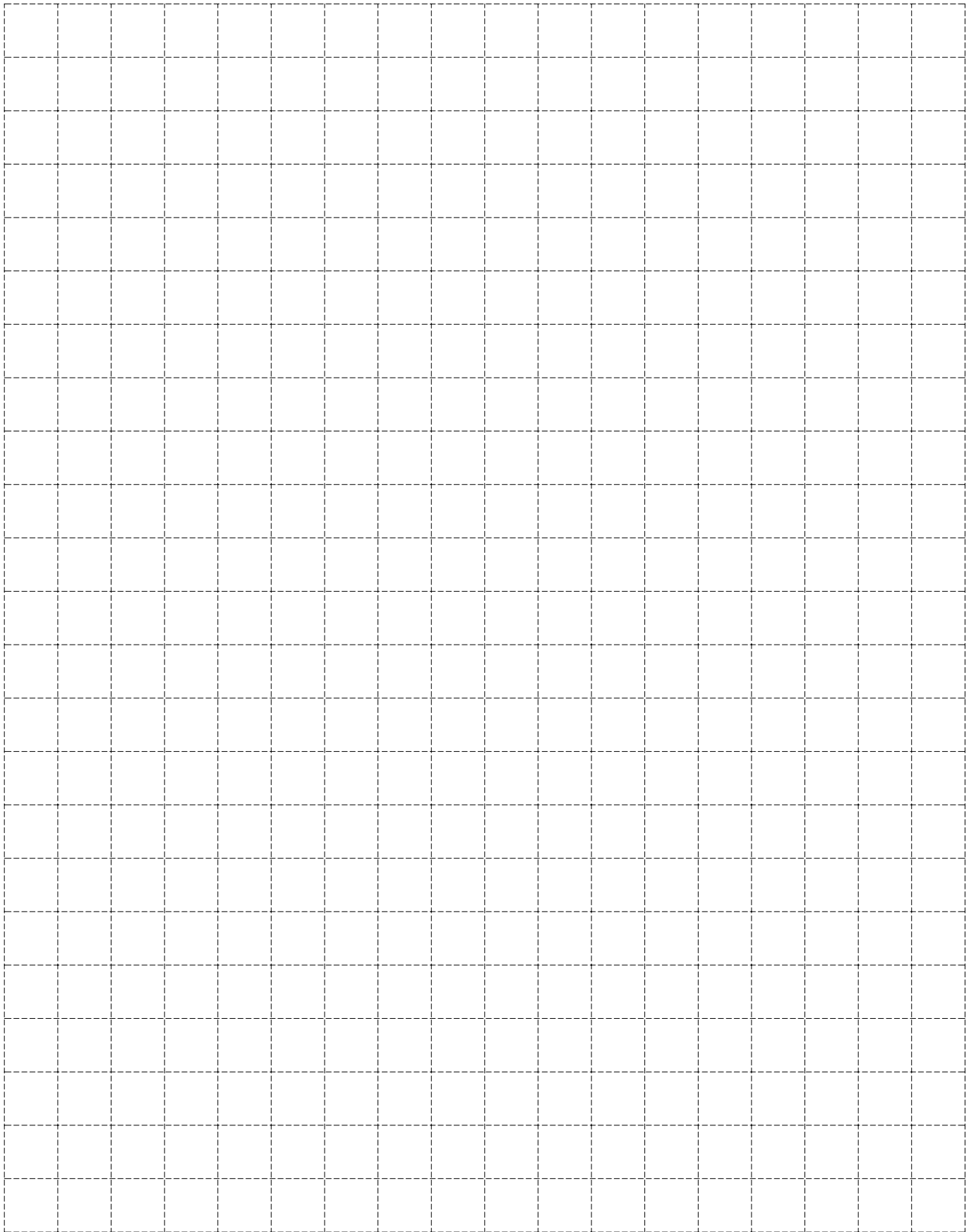

**Generalità**

I sistemi progettati e sviluppati dalla Secco Sistemi sono idonei per la fabbricazione di un'ampia gamma serramenti, vetrate e facciate in metallo. I sistemi sono rivolti ad aziende esperte e professionali nel campo della lavorazione dei metalli e della costruzione di serramenti e facciate, che sono a conoscenza delle normative di riferimento, delle direttive e delle specifiche tecniche del fornitore del sistema, nonché delle fondamentali regole dell'arte per la produzione e installazione di questi manufatti. Tutta la documentazione tecnica fornita costituisce un riferimento per i tecnici qualificati delle aziende al fine di indicare le modalità per la costruzione dei prodotti. In ogni caso i tecnici qualificati devono analizzare criticamente le indicazioni riportate per verificarne la loro adeguatezza per ogni singola commessa in relazione ai carichi, agli stress previsti e alle condizioni di messa in opera, essendo impossibile riportare in questa documentazione tutte le varianti riscontrabili nei progetti reali.

**Tolleranze**

EBE 65 prevede l'accoppiamento tra i telai esterni e le ante apribili con distanza di 12 mm su porte e 15 mm su finestre. Per garantire il corretto funzionamento degli accessori e delle guarnizioni le lavorazioni devono essere eseguite con particolare attenzione e precisione: si consiglia di mantenere la tolleranza per la dimensione degli elementi apribili compresa tra +0/-2 mm e la tolleranza per il sormonto degli stessi compresa tra +0/+1 mm.

**Taglio/Lavorazioni**

I profili EBE 65 in acciaio zincato, acciaio inox e corten possono essere tagliati con le normali troncatrici a disco utilizzate per i tubolari in acciaio, mentre per il taglio dei profili in ottone possono anche essere utilizzate troncatrici per le serie di alluminio. Vista la loro particolare dimensione e forma si consiglia di utilizzare le ganasce di taglio previste dal sistema per assicurare una perfetta stabilità dei profili durante il taglio. La verifica del taglio, sia per la sezione inclinata a 45° che per la sezione verticale a 90°, dovrebbe garantire una tolleranza compresa tra -1°/+1°. Tutte le lavorazioni devono essere eseguite con il rispetto della seguente nota tecnica ed eventuali modifiche concordate con l'ufficio tecnico Secco Sistemi.

**Saldatura**

I profili EBE 65 possono essere saldati con i tradizionali sistemi di saldatura (MIG/MAG, TIG), con un idoneo sistema di lubrificazione/refrigerazione e utilizzando le istruzioni presenti nella presente nota tecnica ed evitando di saldare in prossimità della giunzione a taglio termico. L'eventuale riscaldamento del poliuretano libera sostanze gassose a base di aldeidi e CO: per tale ragione si consiglia di saldare con gli appositi DPI previsti e in zone con sufficiente areazione e in presenza di sistema per l'evacuazione dei fumi. I profili in corten devono essere saldati con apposito filo in corten mentre per i profili in ottone si può utilizzare un filo CuSi3. Si raccomanda di saldare in profondità e senza lasciare fori e porosità le aree in contatto, di lisciare e pulire adeguatamente la superficie saldata per garantire una corretta resistenza strutturale all'angolo e permettere una successiva verniciatura senza imperfezioni estetiche visibili (pori e ondulazioni).

**Verniciatura/Brunitura**

I profili EBE 65 sono stati progettati per essere verniciati a polveri in forni con temperature di 180°C per 25 minuti. La zona a taglio termico in poliuretano non è in grado di accogliere con sufficiente adesione le polveri poliesteri e perciò si consiglia di ricoprire tali zone, nelle sole parti destinate ad essere in vista, con apposite pellicole adesive idonee al passaggio in forno.

I telai prima della verniciatura o della brunitura devono essere forati come da istruzioni presenti in questa nota tecnica per permettere la fuoriuscita dei liquidi utilizzati durante il pretrattamento delle superfici. All'uscita del forno di polimerizzazione della polvere i telai vanno rimossi accuratamente e adagiati in posizione piana sino al loro completo raffreddamento. Si consiglia di seguire il ciclo di pretrattamenti e verniciatura presente nella documentazione Secco Sistemi.

**Vetrazione**

Il sistema di fissaggio del vetro prevede l'utilizzo di fermavetri agganciati all'interno tramite clips o boccole interne e mandati in pressione con l'incastro dell'apposita guarnizione interna; all'esterno è previsto l'utilizzo di una guarnizione perimetrale continua giuntata e sigillata in un angolo superiore o di una guarnizione butilica di fondo giunto e un cordolo di silicone applicato secondo le prescrizioni tecniche del fornitore del prodotto. Per il corretto funzionamento del sistema si suggerisce di verificare la perfetta compressione delle guarnizioni interne del fermavetro.

**Installazione**

La corretta installazione deve garantire il mantenimento delle performance dichiarate nella marcatura CE e testate in laboratorio. Si consiglia di progettare un corretto numero di fissaggi in relazione al tipo di contro telaio/muratura esistente e alle dimensioni degli elementi da installare. Al termine dell'installazione si verifichi il corretto funzionamento del serramento (facilità di apertura/chiusura, stabilità dell'anta aperta a riposo, etc.), il rispetto delle fughe e del sormonto tra ante apribili e telai fissi, il regolare posizionamento delle guarnizioni e delle sigillature, il drenaggio del giunto aperto e la mancanza di difetti estetici sulle superfici dei telai e del vetro.

**General information**

The systems designed and developed by Secco Sistemi are suitable for the manufacturing of a wide range of doors, windows and shutters, as well as faces or facades in metal. The systems are designed for professional and expert companies in the metal-working sector and that of construction of doors, windows, shutters and facades. These companies are well aware of the specific regulations and the directions and technical specifications of the system supplier, and also the fundamental rules of the art of manufacturing and installing these products. All the technical documentation provided furnishes a source of reference for the qualified technicians of the companies, giving indications as to how the products should be constructed. These qualified experts must critically analyse the indications to verify their adequacy for each single order in terms of load, stress and conditions of installation, particularly as this documentation cannot provide for all the different variations that may be found in projects.

**Tolerance**

EBE 65 is made by coupling external frames with the opening leaves with a distance of 12 mm on doors and 15 mm on windows. To ensure the correct functioning of hardware and gaskets, tooling must be performed with great care and precision. It is advised to keep the tolerance between  $+0/-1$  mm for opening elements and between  $+0/+0.5$  mm for their overlapping area.

**Cut / Processing**

EBE 65 profiles in galvanized steel, stainless steel and corten steel can be cut with normal saws, like those used for steel pipes. EBE 65 profiles in brass can be cut with saws used for aluminium. Given their dimension and size, it is recommended to use the cutting jaws advised to ensure perfect stability during the cutting procedure. In order to verify the correctness of the cut, the tolerance of both the 45° and the 90° sections must be between  $-1°/+1°$ . All Tooling must be performed in line with this technical note and any variations agreed with Secco Sistemi's Technical Department.

**Welding**

EBE 65 profiles can be welded with the traditional systems (MIG/MAG, TIG), with an appropriate lubricating/cooling system and according to the instructions as per this technical note. Avoid welding near the thermal break joint. Heating any polyurethane items releases gaseous substances containing aldehydes and CO. For this reason it is recommended to weld with the special Personal Protective Equipment suggested and in areas with sufficient ventilation and fume-disposing systems. The corten profiles must be welded with special corten wire, while for profiles in brass a CuSi3 wire can be used. It is recommended to weld in depth, to avoid leaving any holes or porosity on the surfaces and to smooth and clean the welded surface thoroughly. This is to guarantee a proper structural resistance at the corner and to allow for later painting without any visible imperfections (pores and ripples).

**Painting/Burnishing**

EBE 65 profiles have been designed to be painted with the powder coating technique in industrial ovens at temperatures of 180°C for 25 minutes. The thermal break area is not designed to absorb polyester powders and therefore it's advised to cover the visible areas with appropriate industrial-oven-resistant adhesive films (SA1024 and SA1033). Holes must be drilled in the frames (as per instructions in these technical specifications) before painting or burnishing in order to allow drainage of any liquid used as a pre-treatment of the surfaces. Once out of the oven, the frames must be accurately removed and laid in a horizontal position until complete cooled.

It is advised to follow pre-treatment and painting cycles as outlined in the Secco Sistemi documentation.

**Glass application**

Glass needs to be secured internally and externally. Internally, glazing beads must be used together with clips or bushings and then secured by pressure with the appropriate gasket; externally a continuous perimetrical gasket should be applied, jointed and sealed in a top corner or a butyl seal and a thread of silicone that must be applied according to the product supplier's technical specifications. In order to ensure the correct functioning of the system, it is recommended to verify the proper pressurization of the internal glazing bead gaskets.

**Installation**

Proper installation must guarantee that the performances declared in the EC marking and verified in the lab will remain constant. It is advised to arrange a correct series of set ups with reference to the existing type of subframe/brickwork and to the dimensions of the elements to install. Once installation is completed, the proper functioning of the window/door (easiness of opening/closing, stability of the open leaf, etc.), should be tested as well as the correctness of joints and overlapping areas between opening leaves and fixed frames, the proper positioning of gaskets and seals, the drainage of frames with weep system and the absence of any aesthetic defects on the frame and glass surfaces.

AT1000

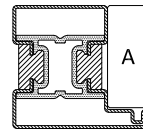
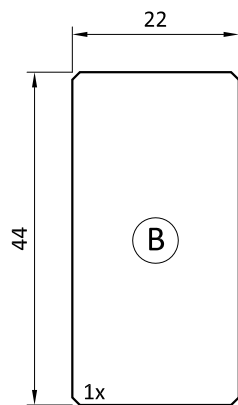
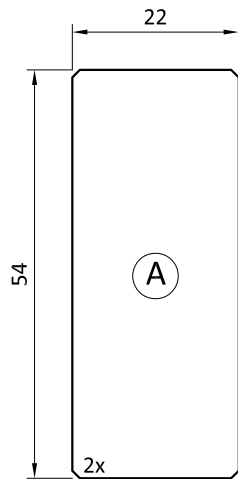

P.1001

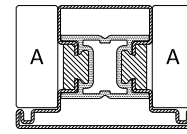

P.1002

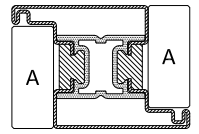

P.1003

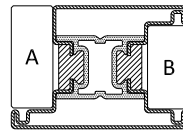

P.1005

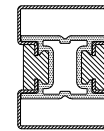

P.1010

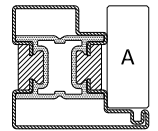

P.1011

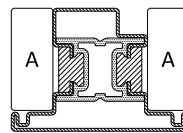

P.1012

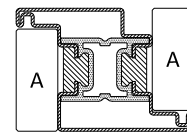

P.1013

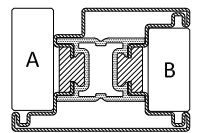

P.1015

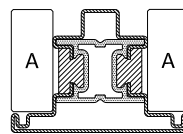

P.1022

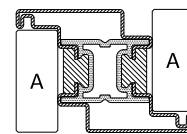

P.1023

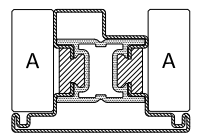

P.1027

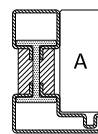

P.1201

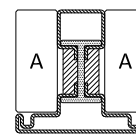

P.1202

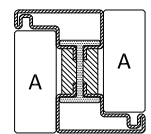

P.1203

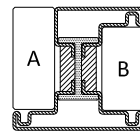

P.1205

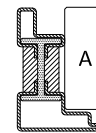

P.1211

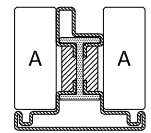

P.1212

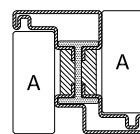

P.1213

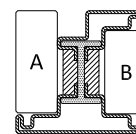

P.1215



P.1220

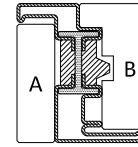
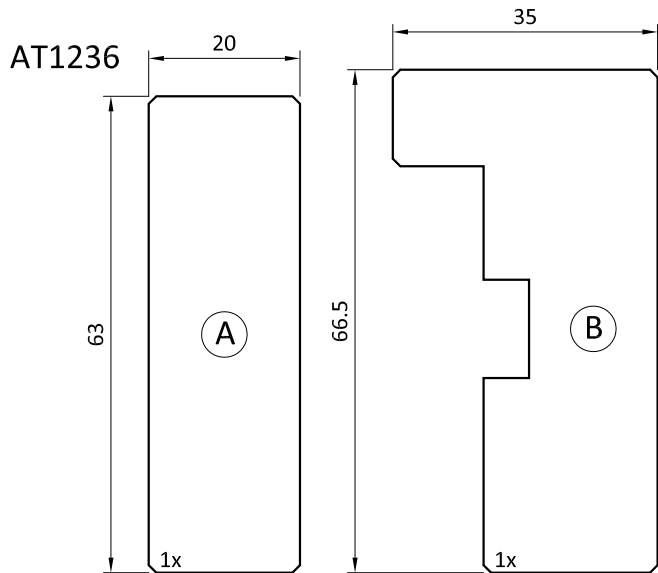

P.1233

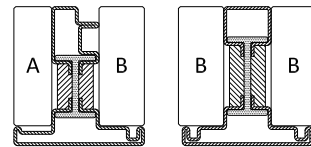
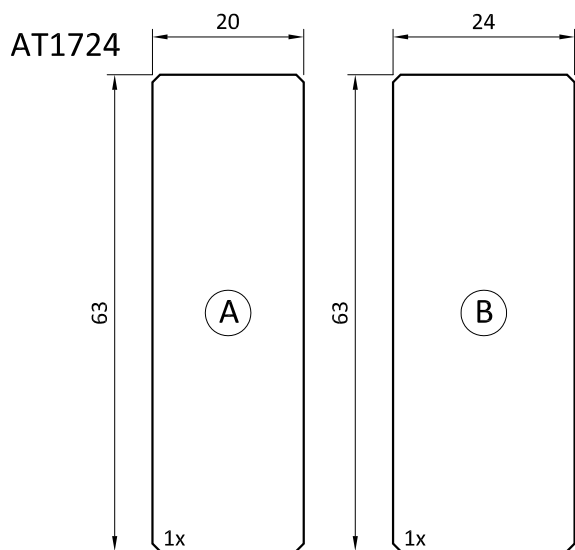

P.1724

P.1702

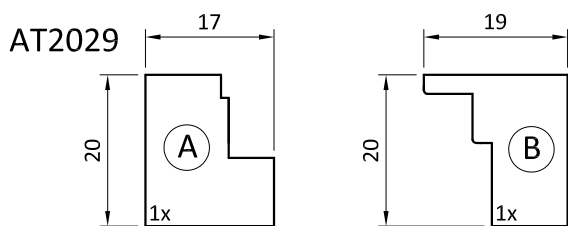

P.2028

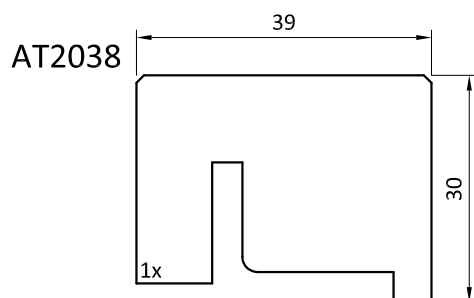

P.2038

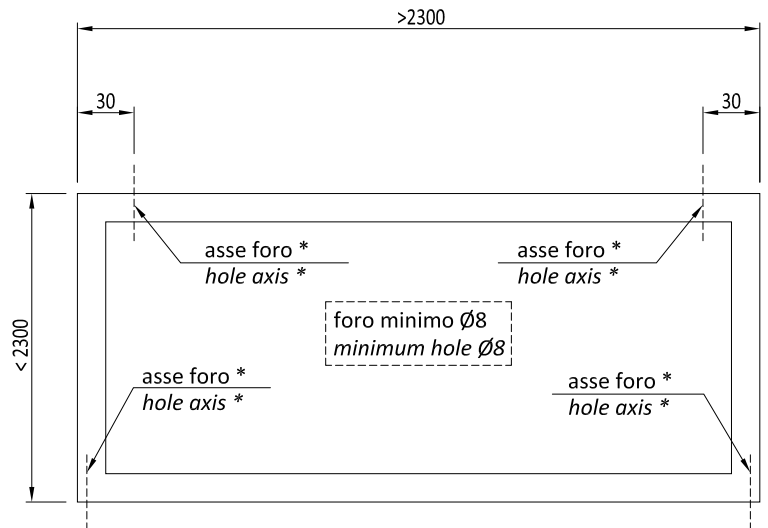
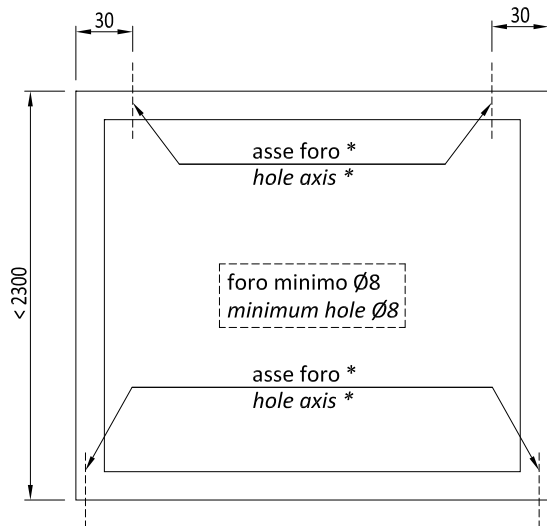

\* forare alla massima estremità  
\* to be drilled on the extremity

N.B. dimensioni orientamento telai indicative - da verificare con l'impianto di verniciatura/brunitura scelto

N.B. frame dimensions are indicative - they have to be checked with the powder painting / burnishing plant

FORATURA LATO INFERIORE PER SCOLO LIQUIDI  
DRILLING BOTTOM FRAME FOR LIQUID DRAINAGE

FORATURA LATO SUPERIORE PER APPENDERE  
DRILLING UPPER FRAME FOR FRAME HANGING

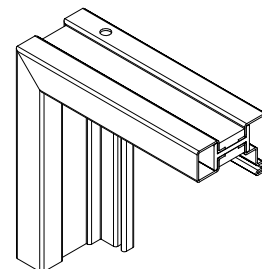
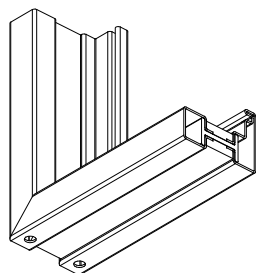
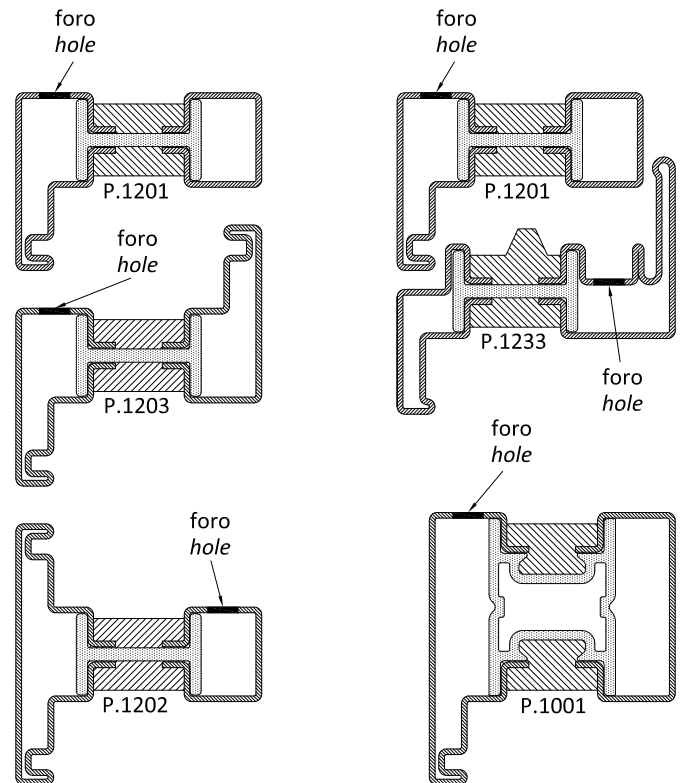
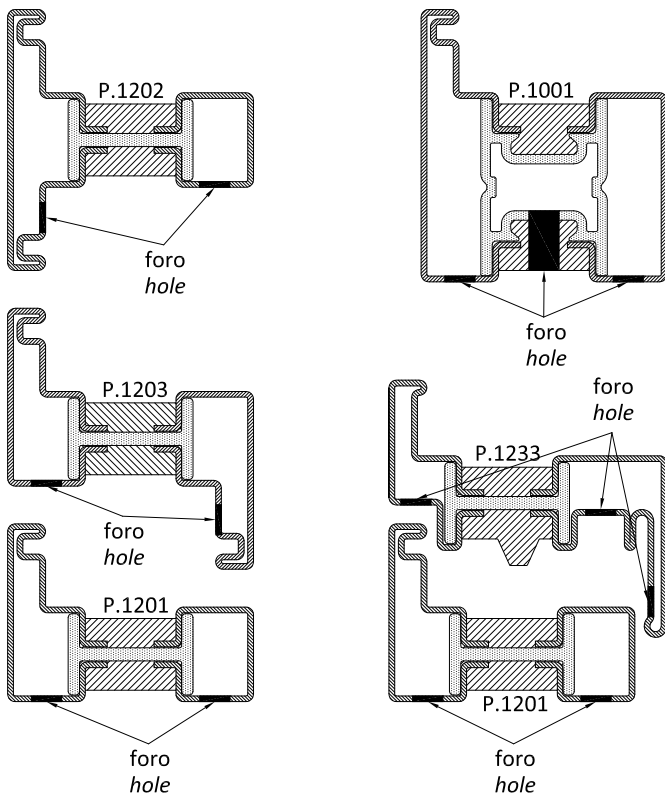

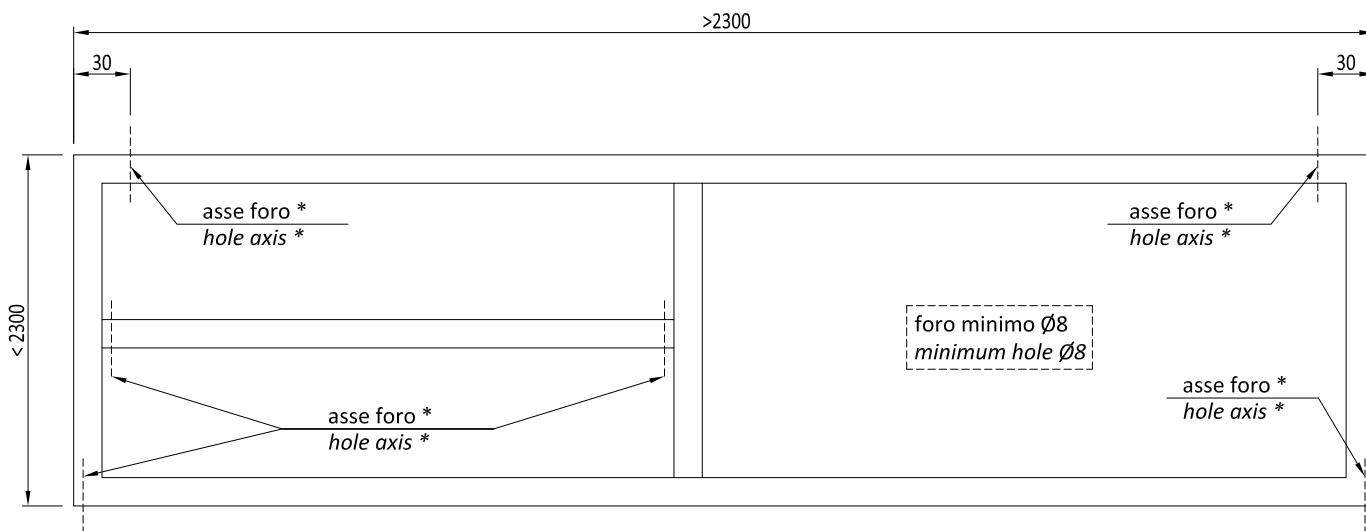

\* forare alla massima estremità

\* to be drilled on the extremity

N.B. dimensioni orientamento telai indicative - da verificare con l'impianto di verniciatura/brunitura scelto

N.B. frame dimensions are indicative - they have to be checked with the powder painting / burnishing plant

FORATURA MONTANTI  
DRILLING MULLION

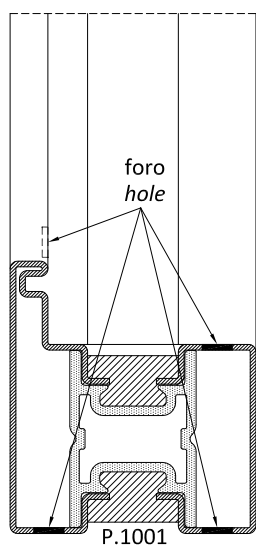
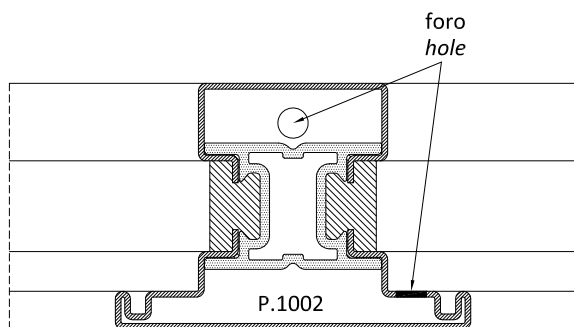

FORATURA TRAVERSI  
DRILLING TRANSOM

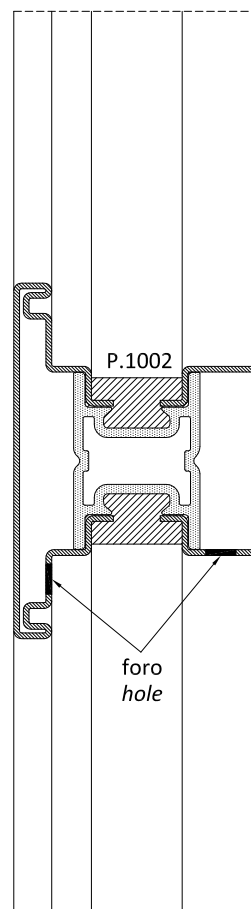



**Troncatrice**caratteristiche minime della macchina

- Potenza: 1.8 – 2.5 kW;
- Possibilità di taglio a 45° nei due sensi e a 90°;
- Velocità di taglio ideali: 15-30 giri/min per acciaio inox;  
60-90 giri/min per acciaio zincato e corten,  
90 giri/min o superiori per bronzo (OT/67);
- Capacità di taglio: 150 x 80 mm a 90°;  
100 mm taglio a 45°.

caratteristiche della lama

- Lama da 350 mm con spessore 2.5 mm;
- N° denti: - 300 per tagli a 45°;  
- 350 per tagli a 90°;
- Materiale: HSS (verificare materiali di commercio con finiture che migliorano la durata delle lame).

NB: è possibile tagliare la lega OT/67 con le stesse macchine dell'alluminio.

**Pantografo**caratteristiche minime della macchina

- Mandrino con velocità regolabile 2000-11000 giri/min (per un corretta lavorazione su acciaio inox è necessario operare a n° ridotto di giri < 4000);
- Struttura in ghisa adatta al taglio acciaio;
- Testata pesante per limitare le vibrazioni;
- Chiusura del profilo da lavorare con morse.

caratteristiche minime delle frese

- Materiale: HSS (verificare materiali di commercio con finiture che migliorano la durata delle frese);
- Frese a 4 denti;
- Frese con diametro 5 mm per le lavorazioni di scasso.

**Forature**montaggio componenti di chiusura e movimentazione sui profilati in acciaio inox

- Forare con punte da trapano HSS del diametro indicato sulla corrispondente tavola tecnica;
- Maschiare il foro con vite autofilettante zincocromata avente diametro corrispondente alla vite inox fornita nel kit con l'articolo da montare;
- Posizionamento e fissaggio definitivo dell'articolo con le viti inox in dotazione.

fresatura di cave e asole sui profili inox

- Adoperare macchine (pantografi o fresatrici) adeguate alle lavorazioni dell'acciaio;
- Regolazione del numero di giri max (3000 giri/1');
- Impiego di frese di diametro massimo di 8mm a 4 pale in acciaio HSS;
- Abbondare con la lubrificazione, concentrata sull'utensile;
- Ridurre l'avanzamento fino ad accertare un taglio il più regolare possibile;
- È normale un'usura accelerata dell'utensile.

**Cutter**Minimum requirements for the use of the machine

- Power: 1.8 – 2.5 kW;
- Possibility of cutting at 45° in both directions and at 90°;
- Ideal cutting speed: 15-30 rmp for stainless steel;  
60-90 rmp for galvanised and corten steel;  
90 rmp or higher for bronze (OT/67);
- Cutting capability: 150 x 80 mm at 90°;  
100 mm cut at 45°.

Blade specifications

- 350 mm blade with a 2.5 mm thickness;
- Number of teeth: 300 for 45° cut;  
350 for 90° cut;
- Material: HSS (please verify availability of longer lasting material on the market).

Note: OT/67 alloy can be cut with machines made for aluminum.

**Phantograph**Minimum requirements for the use of the machine

- Mandrel with a 2000-11000 rmp adjustable speed (for a proper stainless steel processing a slower speed is required i.e.<4000 rpm);
- Machine should be made of cast iron suitable for steel cutting;
- Heavy head in order to limit vibrations;
- Secure the profile to be processed in jaws.

Minimum requirements for the use of a milling machine

- Material: HSS (please verify availability of longer lasting material on the market);
- Use a 4-tooth milling machine;
- Use a milling machine with a 5-mm diameter for groove processing.

**Drilling**How to mount closing and moving components on a stainless steel profile

- Use a HSS drill. The diameter of the drill is indicated in the technical note;
- Thread the hole with self-threading zinc-plated screws with the same diameter as the stainless steel screw provided with the kit;
- Position and secure the item with the stainless steel screws provided.

Milling slots and loops in the profiles

- Use machines designed for steel processing (pantographs or milling machines);
- Max rpm setting (3000 rpm);
- Use milling machines with a diameter no bigger than 8 mm and with 4 HSS steel blades;
- Exceed with lubrication, mainly on the machine;
- Processed slowly until the milling is as clean as possible;
- Expect a fast wearing of the machine.

1. Controllo materiale in arrivo / *Incoming equipment Control*

Verifica visiva dell'intergrità delle barre con attenzione a: / *Profiles wholeness visual control paying attention to:*

- Strisci profondi / *Deep scratches* verifica visiva / *visual control*
- Botte e avvallamenti sulla superficie / *Bumps and dips on surface* verifica visiva / *visual control*
- Rettilineità barre / *Profiles straightness tolerance* 0,002 x L
- Svergolamento / *Profiles twist tolerance* 1° x m

2. Taglio barre e controllo barre / *Cut and Control of profiles*

- Misura lunghezza / *Length measurement* ±0.5 mm
- Verifica 45° / *45° Control* ± 1°
- Verifica 90° / *90° Control* ± 1°

**MATERIALI****ACCIAIO INOX****Materiale**

Profilati ricavati da nastro di lamiera di acciaio inox laminato a freddo pre-trattato industrialmente per garantire la massima qualità e uniformità.

**Caratteristiche fisiche**

AISI 316L Marino (X2 CrNiMo 17-12-2)

**Norme di riferimento**

EN 10088-2; EU 114

**Trattamenti superficiali**

Finitura satinata: ottenuta su nastro AISI 304 con finitura superficiale 2B con successiva satinatura con abrasivi a grana 240-280.

Finitura lucida: ottenuta su nastro AISI 316L (marino) con finitura superficiale 2R, riflettività 53% e successiva lucidatura a specchio.

Finitura Scotch Brite: ottenuta su nastro AISI 316L (marino) con finitura superficiale 2B con successiva spazzolatura Scotch Brite.

**ACCIAIO COR-TEN****Materiale**

Profilati ottenuti da nastro in acciaio altoresistenziale, autopassivante (che un tempo veniva commercializzato con il nome Cor-Ten) tale da formare, se esposto all'aria, uno strato di ossido uniforme e stabile che, ricoprendo la lamiera, ne arresta la corrosione atmosferica.

**Caratteristiche fisiche**

Fe 510 X (C max % 0,12; Si % 0,25-0,75; Mn % 0,20-0,50; P % 0,07-0,15; Cu % 0,25-0,55; Cr % 0,30-1,25; Ni max % 0,65)

**Norme di riferimento**

EN 10149

**Trattamenti superficiali**

Dopo la profilatura il materiale viene immerso in speciali bagni ossidanti tali da accelerare la formazione dello strato protettivo. Raggiunta la tonalità desiderata della superficie si procede ad una ceratura di stabilizzazione del materiale.

**ACCIAIO ZINCATO VERNICIATO****Materiale**

Profilati ottenuti da nastro in lamiera di acciaio zincato a caldo sistema Sendzimir finitura skinpassata

**Caratteristiche fisiche**

FeP02 GZ 200 (copertura di zinco pari a 200gr/m<sup>2</sup> per faccia)

**Norme di riferimento**

UNI EN 10142/3/7; EURONORM 143

**Trattamenti superficiali per la verniciatura**

La preparazione del supporto zincato si effettua tramite i processi di sgrassaggio, decapaggio e lavaggio in acqua. Segue l'applicazione di uno strato di zinco per fosfatazione seguito da lavaggi in acqua demineralizzata. Infine applicazione della mano a finire con polveri poliestere cotte in forno a 180 °C per 25 minuti.

**LEGA DI RAME OT67****Materiale**

Profilati ottenuti da nastro di Lega di Rame OT67 laminato a freddo rincrudito allo stato grezzo.

**Caratteristiche fisiche**

Cu Zn 33 CW 506L (OT 67, 67% rame)

**Norme di riferimento**

EN 1652:1999

**Trattamenti superficiali**

Finitura brunita: dopo la profilatura viene eseguita una ricottura di distensione, quindi la pulitura meccanica con abrasivo e la successiva brunitura per immersione con liquido brunitore; il profilo viene poi lavato e asciugato ed infine protetto mediante trattamento con olio di vaselina.

Finitura lucida: dopo la profilatura viene eseguita una ricottura di distensione e successivamente la lucidatura a specchio.

**MATERIALS****STAINLESS STEEL****Materials**

Sections processed out of the cold-rolled coils, industrially pre-treated for utmost quality and uniformity.

**Physical features**

AISI 316L Marino (X2 CrNiMo 17-12-2)

**Norms of reference**

EN 10088-2; EU 114

**Surface treatment**

Satined: obtained on AISI 304 coil 2B pre-finish with post-treatment by means of abrasive 240-280 in grain size.

Polished: obtained on AISI 316L (marine) coil pre-finish with 2R surface finish, 53% reflectivity, and mirror post-polish.

Scotch Brite: obtained on AISI 316L (marine) coil 2B pre-finish with Scotch-Brite post-scrubbing.

**CORTEN STEEL****Materials**

Sections processed out of highly resistant self-oxidising steel coils – once traded under the name Cor-Ten. If exposed to the open air, it produces a uniform protective layer that reduces weather corrosion.

**Physical features**

Fe 510 X (C max % 0,12; Si % 0,25-0,75; Mn % 0,20-0,50; P % 0,07-0,15; Cu % 0,25-0,55; Cr % 0,30-1,25; Ni max % 0,65)

**Norms of reference**

EN 10149

**Surface treatment**

After forming, sections are plunged into a special oxydising bath to catalyze formation of the protective coating. Once the desired tone obtained, sections are stabilized by a wax coating.

**GALVANIZED AND PAINTED STEEL****Materials**

Sections processed out of hot galvanized steel coils, band "Sendzimir, skinpassed finishing.

**Physical features**

FeP02 GZ 200 (with zinc coating of 200 gr/sq x m on both faces)

**Norms of reference**

UNI EN 10142/3/7; EURONORM 143

**Pre-painted surface treatment**

The preparation of a galvanised surface is made through several processes: degreasing, pickling and washing. A coating of zinc is then applied through a phosphatising process followed by rinses in demineralised water. A final coat is then applied with polyester powders baked at 180 °C for 25 minutes.

**COPPER ALLOY OT67****Materials**

Sections processed out of copper alloy coils, industrially cold-rolled.

**Physical features**

Cu Zn 33 CW 506L (OT 67, 67% copper e 33% zinc)

**Norms of reference**

EN 1652:1999

**Surface treatment**

Burnished finish: after forming, the product is submitted to stress relieving, then to mechanical cleaning with abrasive products and ultimately to burnishing by plunging into a burnishing solution. It is then washed and dried and protected with a vaseline coating.

Glossy finish: after forming, the product is submitted to stress relieving and then mirror-like polished.

## INDICE ANALITICO | SUBJECT INDEX

AC1001I	4.2.5	AC1235	4.4.59
AC1002I	4.2.5	AC1237	4.4.48-50
AC1003I	4.2.6	AC1356	4.4.15 4.4.56 4.4.71
AC1004I	4.2.7	AC1708I	4.2.19
AC1005I	4.2.8	AC1714	4.4.3-5 4.4.9
AC1006I	4.2.8	AC1716	4.4.7-9
AC1007I	4.2.9	AC1730I	4.2.17
AC1008I	4.2.9	AC1731I	4.2.14
AC1009I	4.2.6	AC1732I	4.2.15
AC1013I	4.2.7 4.2.10	AC1733I	4.2.16
AC1014	4.3.1-2	AC1733IE	4.2.16
AC1020M	4.3.44 4.4.72	AC1735I	4.2.14
AC1020R	4.3.44 4.4.72	AC2608	2.8.11
AC1021	4.2.20	AC2632/C	4.4.51 4.4.62
AC1022	4.2.21	AC5002	4.3.41
AC1023	4.2.22	AC5037	4.4.69
AC1024ID	4.2.10	AC5056	4.4.15 4.4.56 4.4.71
AC1024IS	4.2.10	AC6023	4.3.13
AC1033.	4.3.4-6	ACV942	4.3.42
AC1033/R	4.3.6	ACV943	4.3.42
AC1037.	4.3.7-9	ACV944	4.3.42
AC1037/R	4.3.9	ACV947	4.3.42
AC1039	4.4.64-65	ACV948	4.3.42
AC1040	4.3.30	ACV949	4.3.42
AC1046	4.4.66	ACV952	4.3.43
AC1046M	4.4.67	ACV953	4.3.43
AC1058	4.3.10-12	ACV954	4.3.43
AC1065W D-S	4.3.15-17	ACV957	4.3.43
AC1066W D-S	4.3.15 4.3.18-19	ACV958	4.3.43
AC1067W D-S	4.3.20-22	ACV959	4.3.43
AC1070	4.3.23 4.3.25-26	ACV970	4.4.71
AC1071	4.3.24-26	ACV971	4.4.71
AC1072	4.3.27-29	ACV972	4.4.71
AC1075	4.3.23-29	ACV973	4.4.71
AC1080I	4.3.14	ACV974	4.4.71
AC1081	4.3.31-33	ACV976	4.4.71
AC1081AT	4.3.36-4.3.40	ACV977	4.4.71
AC1201I	4.2.12	ACV979	4.4.71
AC1202I	4.2.12 4.2.17	AG1224	4.4.61
AC1203I	4.2.13	AG1264	4.4.55-57
AC1207I	4.2.18	AG1271-2-5-6	4.4.14 4.4.19-21 4.4.38-42 4.4.45-46
AC1209I	4.2.13	AG1273	4.4.13
AC1211I	4.2.23	AG1274	4.4.55-56 4.4.58
AC1211IA	4.2.24	AG1278	4.4.13
AC1215	4.4.1	AG1281-2-5-6	4.4.14 4.4.25-28 4.4.38-42 4.4.45-46
AC1219.	4.4.6-7	AG1291-2-5-6	4.4.14 4.4.32-34 4.4.38-42 4.4.45-46
AC1219NE	4.4.6-7	AG1385	4.4.52-53
AC1221	4.4.60	AG1386	4.4.54
AC1223I	4.4.63	AG6530	4.4.47
AC1231S	4.4.63	AGA271-5	4.4.13 4.4.35-36 4.4.40-44

AGA775 .....	4.4.13 4.4.37 4.4.40-44
AGE271-2-5-6 .....	4.4.13 4.4.16-17 4.4.21 4.4.38-44
AGE775-6 .....	4.4.13 4.4.18 4.4.21 4.4.40-44
AGE281-2-5-6 .....	4.4.13 4.4.22-23 4.4.28 4.4.38-44
AGE785-6 .....	4.4.13 4.4.24 4.4.27 4.4.40-44
AGE291-2-5-6 .....	4.4.13 4.4.29-30 4.4.34 4.4.38-44
AGE795-6 .....	4.4.13 4.4.31 4.4.34 4.4.40-44
AT1000 .....	5.1.4
AT1236 .....	5.1.4
AT1724 .....	5.1.4
AT2029 .....	5.1.4
AT2038 .....	5.1.4
CV5001 .....	2.9.11
CV5012 .....	2.9.11
GU1034 .....	4.3.36 4.3.40
GU1211 .....	4.4.64 4.4.68
P.1027 .....	4.3.3
P.1030 .....	4.3.34-35 4.3.38-39
P.1129 .....	4.3.37
P.2027 .....	4.4.11-12











# METALFORM

MASTERS OF METAL

**UNITED KINGDOM**

**METALFORM**

**NORWAYMETAL LTD**

53 Chelsea Manor Street

London, SW3 5RZ

**SALES@METALFORM.UK**

**+44 20 81298814**

**GERMANY**

**METALFORM GMBH**

Carl-Zeiss-Ring 15A

85737 Ismaning

**SALES@METALFORMGROUP.DE**

**+49 17663630406**

**NORWAY**

**METALFORM AS**

Brochmannsveien 2

1950 Rømskog

**SALG@METALFORM.NO**

**+47 401 62 446**

**METALFORMGROUP**

**SALES@METALFORMGROUP.COM**